



Installation Manual

AdvanTex[®] **AX100 Treatment Systems** *Commercial Applications*

Orenco[®]
Orenco Systems, Incorporated

1-800-348-9843
+1-541-459-4449

www.orenco.com

Table of Contents

<i>Before You Begin</i>	<i>Page 1</i>
-------------------------------	---------------

Installation Steps

Step 1:	Install Access Risers	Page 2
Step 2:	Install Recirculating Valve	Page 3
Step 3:	Prepare Site for AdvanTex® Pods	Page 5
Step 4:	Set AdvanTex Pods	Page 5
Step 5:	Install Filtrate Lines	Page 7
Step 6:	Install Vent Fan Assembly, If Applicable	Page 7
Step 7:	Install Biotube® Pump Packages	Page 8
Step 8:	Install Control Panels	Page 10
Step 9:	Connect Transport Lines to Pods	Page 10
Step 10:	Install Air Ventilation Lines	Page 11
Step 11:	Backfill Installation	Page 12
Step 12:	Prepare Pod for Operation	Page 13
Step 13:	Prepare for System Start-Up	Page 14
Appendix:	Grommet Installation Instructions	Page 15

Introduction

This manual covers installation of AdvanTex® AX100 Treatment Systems in commercial applications. Please read through this entire manual before starting installation. This installation manual is generic in nature and not intended to replace requirements and instructions detailed in your engineering plans. If you discover any inconsistencies between your engineering plans and the instructions in this manual, bring the matter to your engineer's attention.

About Pipe Sizes

All pipe diameters given are U.S. nominal PVC pipe sizes. If you are using metric pipe, you may need adapters to connect to the U.S. fittings supplied.

Before You Begin

As the installer of an onsite wastewater treatment system, you play a crucial role. Regulators, manufacturers, dealers, property owners, neighbors, service providers ... we all rely on your expertise and good work.

You are about to install a commercial AdvanTex® Treatment System, which includes one or more AdvanTex pods, Biotube® pumping packages, and control panels. Orenco Systems®, Inc. is one of America's leading suppliers of equipment for residential and community wastewater collection and treatment systems. At Orenco, we manufacture complete systems, and wastewater collection and treatment is our only job. You can be confident that you have purchased the best equipment available. And we've worked hard to make your installation as easy and "hassle-free" as possible.



Property owners, neighbors, regulators, dealers, manufacturers, and service providers all depend on your careful installation.

To protect workers and equipment, read this entire manual before you begin installing your commercial AdvanTex Treatment System, and call your AdvanTex Dealer if you have any questions.

In particular, review the preparation steps and the installation sequence before doing anything. We recommend that you follow the installation sequence described. You'll save yourself time and money on installation day, and you'll reduce the potential for call-backs.

Also, be sure to schedule a preconstruction meeting with an Orenco representative, the engineer, contractor, electrician, operator, inspector/regulator, and owner to discuss the installation process, inconsistencies in the plans, vague or missing specs, key inspection points, and possible regulatory issues.

Lastly, inspect your order for completeness and inspect each component for shipping damage. Check to be sure instructions and items supplied comply with your state and local regulations. Carefully read and follow all instructions. Improper installation may void warranties.

We're very proud of this wastewater treatment system. Like all our products, the AdvanTex Treatment System has gone through extensive research, development, and field-testing. Each component is then built to written specifications and subjected to quality review before shipping. If you need any technical support, please contact your authorized AdvanTex Dealer. The Dealer can also provide repair and replacement instructions and replacement components. If there is no authorized AdvanTex Dealer in your area, call Orenco Systems, Inc. at (800) 348-9843 or (541) 459-4449.

Step 1: Install Access Risers

IMPORTANT: Make sure each tank has been installed and backfilled sufficiently per the manufacturer's instructions. To install grommets on access risers, see the Appendix in this manual before proceeding.

Step 1a: If riser-tank adapters haven't been installed, install them per the adapter manufacturer's instructions.

Step 1b: For installing access risers on Orenco riser-tank adapters, see Orenco's document NIN-RLA-RR-1, *Access Riser Installation*. General guidelines for installing risers are ...

- For the best possible bond, roughen the bonding surfaces of the adapter and riser with sandpaper.
- Use a clean rag and acetone to remove dirt, debris, and moisture from the bonding surfaces of the adapter and riser.
- Apply a bead of methacrylate adhesive to the bonding surface of the adapter.
- Slide the riser onto the adapter. Before the adhesive begins to set, orient risers with grommeted holes in the directions shown on the engineering plans. Orient risers drilled for electrical conduits to minimize the number of wire bends in the run. (National Electrical Code limits the sum of all bends in a run to 360 degrees.)
- Apply a bead of methacrylate adhesive to the inside of the adapter and riser joint; then use a putty knife or similar tool to form a continuous fillet between them.

Step 1c: Perform a watertightness test on the tank and the adapter joints. Follow the tank manufacturer's instructions for backfilling and watertightness testing. General guidelines for watertightness testing are provided below.

- Make sure the adhesive has set and the tank has been backfilled according to the manufacturer's instructions – typically to the midpoint of the tank.
- Plug the inlet (and outlet, if present) of the tank with a watertight plug.
- Fill the tank with water, to a level 2 inches (51 mm) into the riser.
- Wait at least 30 minutes (or as required by local rules) and then inspect the tank for leaks. There should be no drop in liquid level and no visual leakage from seams, pinholes, or other imperfections.
- Once the tank and riser joints are proven to be watertight, drop the water level in the tank to just below the invert of the inlet (or outlet, if present).

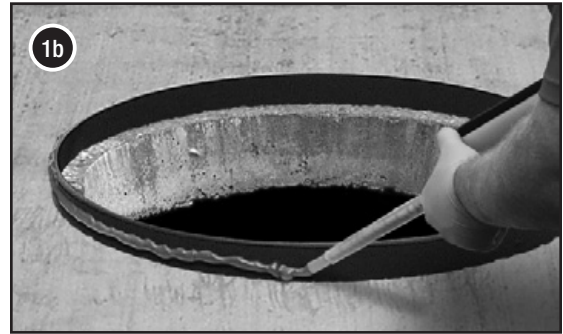

Apply methacrylate bead



Install access riser

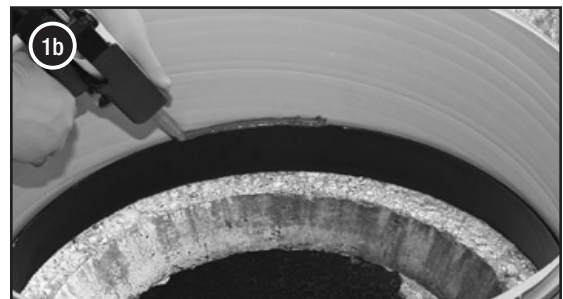

Apply methacrylate bead

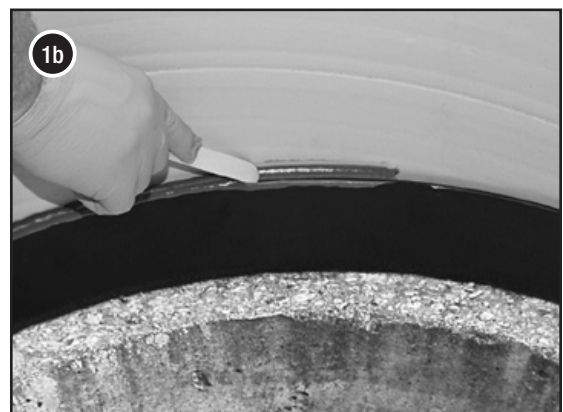

Form continuous fillet

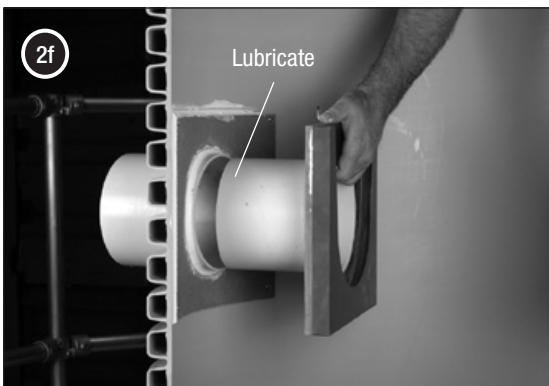
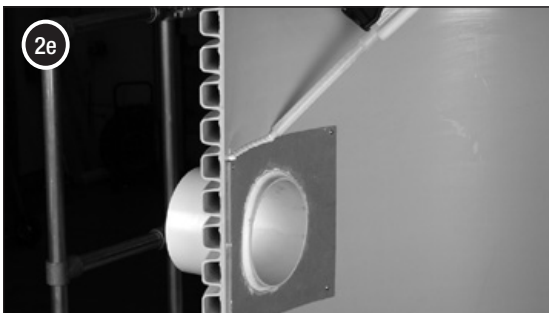

Step 2: Install Recirculating Valve

IMPORTANT: Check the engineering plans to find out whether your installation requires an MM-FRP recirculating valve (shown), or an RSV-type recirculating valve (not shown). For RSV-type recirculating valve installation information, contact your Dealer or Orenco for detailed installation instructions.

Step 2a: If inlet and outlet holes have not been cut, use a hole saw to cut two holes in the riser, exactly opposite from each other, at the desired elevation for the filtrate return line from the AX100 pod. The MM4 valve requires two 4 ½-inch (115-mm) holes, and the MM6 valve requires two 6 5/8-inch (170-mm) holes.

Step 2b: Apply a bead of methacrylate adhesive around the fillet of the flange and another bead about an inch (25 mm) from the first.

Step 2c: From the inside of the riser, insert the flanged fitting through the hole. Press the flange against the inside of the riser, wiggling it until it is firmly contacting the riser.

Step 2d: Drive the supplied stainless steel screws through the holes in the flange to hold the flange in position while the adhesive cures. Adhesive may squeeze out around the edges as you tighten the screws.

Step 2e: Apply a bead of adhesive around the edge of the flange. Then, smooth the bead into a fillet using a tongue depressor or putty knife.

Step 2f: Lubricate the pipe stubs on the quick disconnect brackets with petroleum jelly or pipe lube. Slide each pipe stub into its flanged fitting.

Step 2: Install Recirculating Valve (continued)

Step 2g: The shallow end of the valve body is the inlet end, and the deep end is the outlet end. Push the body into place in the brackets, adjusting the brackets until the body slides in and out easily. If necessary, use a mallet to gently seat the body completely in the brackets.

Note: (MM6-FRP only) When the MM6 unit is completely seated, you will be able to close the stainless steel latches that keep it from floating out once it's in use.

Step 2h: Remove the valve body from the riser, and then use PVC primer and glue to bond the coupling on the ball cage to the pipe stub on the bottom of the body.

Step 2i: Re-install the recirculating valve inside the riser.

Step 2j: (MM4-FRP only) Drive the supplied stainless setscrews into the flanged fittings to keep the assembly from rotating.

Step 2k: The float ball and the cone are connected by a stinger pipe that can be lengthened or shortened by cutting and attaching couplings. With the cone pressed up against the valve seat, the center seam of the float should be approximately at the 100% discharge liquid level in the tank. This liquid level should be on the plans for your installation. If it is not, contact the designer of your system for assistance. Calculate the necessary stinger length adjustment using the equation $(A+B) - 16$, where **A** is the distance from the MM valve invert to the top of the tank and **B** is the distance from the top of the tank to the 100% discharge liquid level. If the stinger needs to be lengthened, the cage may also need lengthening.

Stinger Adjustment Dimensions

A	Distance from invert of MM valve to top of tank
B	Distance from top of tank to the liquid level where 100% discharge is desired
C	Standard cage length: MM4 49 inches (1245 mm), fits stingers up to 36 inches (914 mm) MM6 57 inches (1448 mm), fits stingers up to 40 inches (1016 mm)
D	Middle of float ball (at the 100% discharge liquid level)

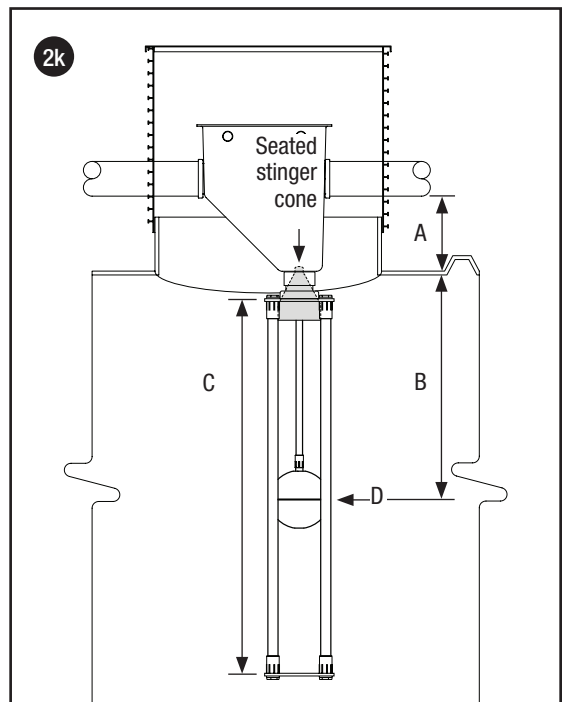
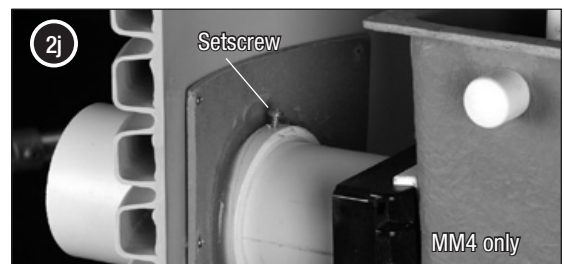
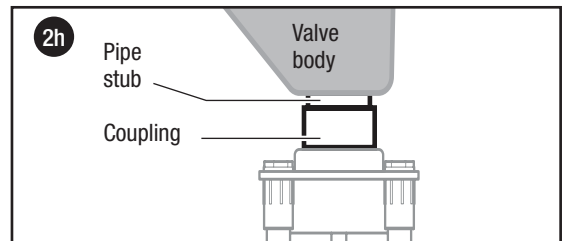
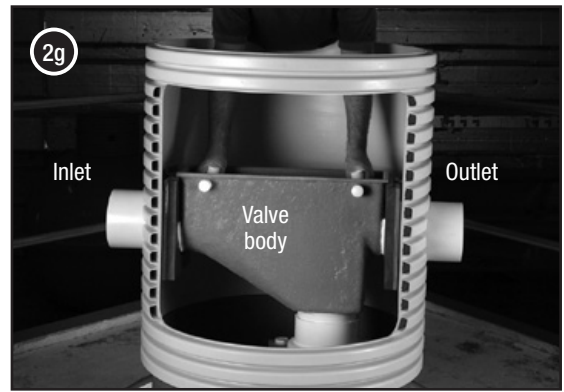



Step 3: Prepare Site for AdvanTex Pods

Step 3a: Before excavating and leveling the pad for the AdvanTex pods, refer to the engineering plans and verify that there are no obstructions on the construction site that might prevent installation of the AdvanTex Treatment System. Since the filtrate return lines must slope down from the pods to the tank, and the ventilation lines must also slope back to the pods, be sure that the elevations and orientations of all components match the plans.

NOTE: The outlet coupling for the filtrate return line is permanently installed in one corner of the AdvanTex pod.

Step 3b: Excavate to the depths determined above for proper elevations. To prevent damage to the pod, make sure the floor of the pad is free of debris, especially rocks and other sharp objects. If the bottom of the excavation is uneven or rocky, lay down a 3-inch (76-mm) bed of sand or pea gravel to create an even, smooth surface.

Step 3c: Compact the excavated area to ensure the pods will sit on a firm base pad and to decrease the chance that the units will settle unevenly.

Step 3d: Outline the pad (with chalk, paint, string, etc.) for all of the AdvanTex pods. Make the pad for each AdvanTex pod at least 12 inches (305 mm) wider and longer than the pod's footprint, and maintain a minimum of 24 inches (610 mm) between pods to allow for maintenance.

NOTE: Pods are tapered, so the lid of the pod is larger than the bottom of the pod.

Step 4: Set AdvanTex Pods

WARNING: Loading and unloading AX100 pods from a flatbed truck can be dangerous. The equipment you use must be able to lift a pod (2000 lb [907 kg] dry) while extended at least four feet (1.2 m) horizontally (about half the pod's width).

Step 4a: Drive the flatbed truck as close to the staging area as possible before unloading, to minimize travel with the suspended pods.

Step 4b: Make sure the lids are bolted down before lifting. Lifting the pod without the lids bolted down will damage the pod. Each AX100 pod ships with four polypropylene straps for lifting. Insert a short 2 × 4 wood block between the straps and the lids (to protect the lids from stress) and hook a chain or cable at least 16 feet long (5 m) through the straps.

Step 4c: Attach the chain/cable to a forklift or crane across the width of the pod.

WARNING: Do not lift the pod with cables stretched lengthwise. Lifting the pod with cables stretched lengthwise will buckle and damage the pod.

Step 4d: Lift the pod slowly until the cables/chains are taut. This will allow you to make sure all the hooks are properly attached to the polypropylene straps. When you are satisfied that the lifting attachments are secure, remove the pod from the truck and offload it onto the construction pad or staging area. Do not extend the lift or crane too far horizontally or the pod may tip the lifting machinery.

Step 4e: Using the lift or crane, suspend the pod just slightly above the construction pad surface so a worker on the ground can maneuver the pod into place. Make sure when you place the pods that the outlets align according to the engineering plan. Once you have the pod over the location you want, slowly lower it so that it sets into place without shifting. The pod, although heavy, can be pushed a few inches by two or three people if necessary.

Step 4f: Remove the cables/chains and pull the polypropylene straps down so they hang below the lids.

NOTE: AdvanTex AX100 pods have been designed for installation in areas that are free of water. If your installation requires placement in an area that is prone to seasonal high water conditions, contact your engineer for antiflotation options. For antiflotation measures specific to the recirculation tank, consult the tank manufacturer.

NOTE: AX100 pods can be bermed, but the bottom of each pod should be no more than 9 inches (230 mm) below the natural grade.



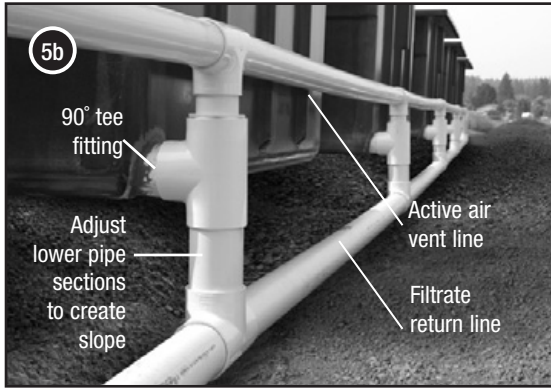

Install PVC filtrate lines:
Active Air Ventilation method shown

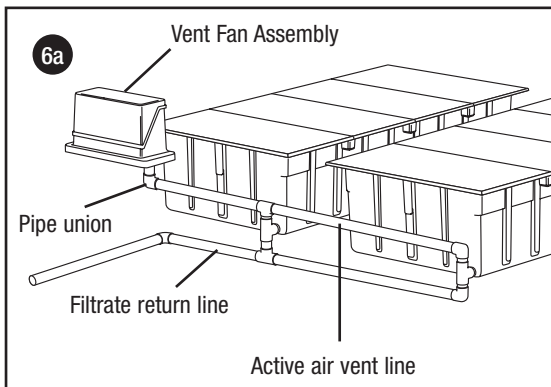
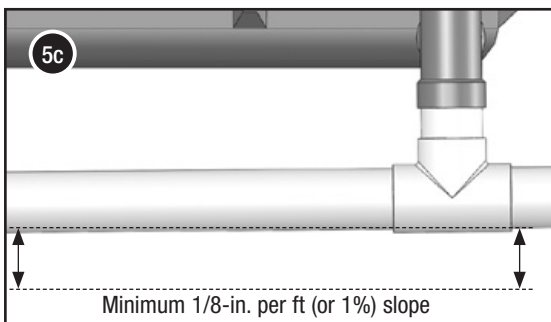
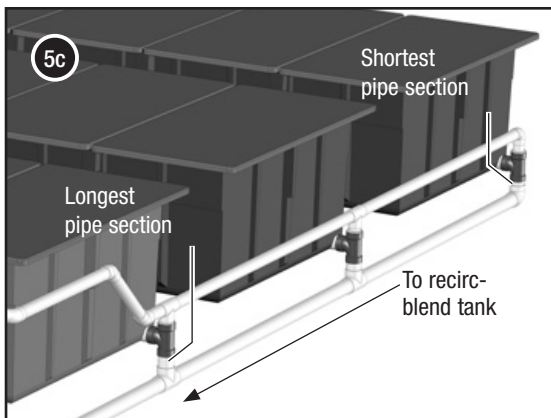

Step 5: Install Filtrate Lines

IMPORTANT: Check the engineering plans now to find out whether the system requires active or passive air ventilation.

Step 5a: AX100 pods ship with a protective cap-plug in each pod's outlet coupling. Remove these plugs from all outlet couplings before connecting the filtrate lines.

Step 5b: Install the PVC filtrate return lines from the outlet coupling in the bottom of the AdvanTex pods to the inlet side of the recirculating valve:

- For Passive Air Ventilation, install the passive air ventilation system according to Step 11c of this manual before continuing.
- For Active Air Ventilation, use 90° tee fittings at the pod's outlet as shown in photo 5b to allow proper air flow through the textile filters. Run the filtrate return lines and vent lines.

Step 5c: Filtrate return lines should be sloped a minimum of 1/8 inch per foot (1%). Be sure the filtrate return line is continuously sloped. Do not allow any bowed, sagged, or flat sections, as this will impair proper drainage and air movement.

NOTE: To achieve a good slope, we recommend adjusting the lengths of the pipe sections that create the slope — called out in photo 5b and figure 5c — by increasing increments along the length of the pipe run: shortest at the pod that's furthest from the tank, longest at the pod that's closest to the tank.

Step 6: Install Vent Fan Assembly, If Applicable

IMPORTANT: See "Vent Fan Assembly Installation" (NIN-ATX-VFA-1) for installation instructions specific to the Vent Fan Assembly unit.

Step 6a: Use the correct diameter pipe and fittings, as specified in the plans, to connect the Vent Fan Assembly to the air vent line from the AX100 pods.

Step 6b: The electrical fan that ships with the product requires 120 volts and should be wired to the terminals in the control panel with a minimum 14-gauge wire. (Outside of North America, consult your Dealer for voltage and wiring requirements.)

Step 7: Install Biotube® Pump Packages

Step 7a: Detach the support pipes from the packaging material, and remove one of the two screws from each pipe. Slide the support pipes through the holes in the support brackets at the top of the vault. Reinstall the screws.

Step 7b: Gently lower the vault into position in the access riser. The support pipes should rest on top of the tank (unless the vault was designed specifically to rest on the tank bottom).

Step 7c: Install splice boxes.

- For external splice boxes — Refer to “External Splice Box Installation Instructions” (EIN-SB-SBEX-1), available online at www.orenco.com, or contact your Dealer.
- For internal splice boxes — Install the splice box into an access riser. Lubricate the outside of the conduit coupling and the grommet with pipe lubricant or an equivalent product and slide the coupling through the upper grommet until the box is snug against the inside riser wall. Use a locally approved electrical sealant or conduit seals outside the riser to provide a barrier between the conduit and the splice box and to reduce condensation in the splice box.

Step 7d: Connect each discharge assembly to its pump. An extension pipe may be necessary to allow the pump to sit at the bottom of the pump vault. Carefully lower each pump and discharge assembly into the flow inducer of each Biotube pump vault.

IMPORTANT: DO NOT use the pump cable to lower the pump! Hold the pump by its discharge assembly.

Step 7e: Using pipe lubricant or an equivalent product, lubricate the access riser grommet and the gray nipple on the discharge assembly. Push the nipple through the grommet and orient the discharge assembly (or assemblies), pump, and filter cartridge for easy removal during maintenance.

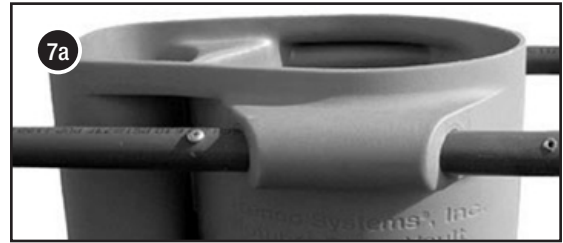

Orient discharge assemblies for ease of maintenance

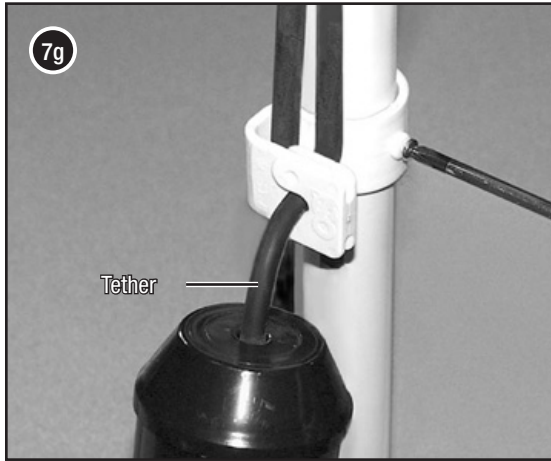

Step 7f: Each float cable has a color marker that indicates the function of the float. Typical commercial AdvanTex systems will have **Y/G/W** (yellow/green/white) or **YP/G/W** (yellow-purple/green/white) timed-dosing float sets. (See table below.) Verify that your float set matches the engineering plans and the panel wiring diagram.

Float	Float Function	
Top	Y High-level alarm	YP High-level alarm/lag-enabled
Middle	G Override timer	
Bottom	W Redundant off/low-level alarm	

WARNING: Do not alter the float tether lengths. Altering tether lengths may disrupt proper operation of the assembly.



Step 7g: The float switch assembly mounts in the pump vault by clipping into the float bracket. Make sure you can detach it without removing the Biotube cartridge or pump vault. If you need to adjust a float setting, loosen the screw in the float collar and slowly back the screw out to a point at which the collar can be adjusted. Do not back the screw completely out of the collar. Rotate the collar on the stem until the float switches can move freely past one another. Tighten the screw and snap the float assembly back into the float bracket.

IMPORTANT: Float positions are critical and should be set according to the engineering plans. Make sure the floats can move freely without interfering with each other and that they do not come in contact with the vault wall.

Step 7h: Wrap the excess float cord cables around the splice box and tie them together to prevent them from slipping back into the vault and interfering with the operation of the floats. Do not cut excess cord, as slack is needed so that the pumps and floats can be pulled out later for maintenance.

Step 7i: Extend filter cartridge and float assembly handles so that they are within easy reach for future servicing.

Step 7j: After installation, confirm that all equipment is properly oriented and easily removable for maintenance.

Step 8: Install Control Panels

A qualified and licensed electrician should install and service the panel and all ancillary wiring, in compliance with the National Electrical Code or other relevant codes. Complete wiring diagrams can be found in the panel's installation manual and in the pouch on the inside of the control panel's door.

Note: If the instructions are missing or have been removed from the door pouch inside the control panel, call Orenco for a replacement.

Wiring will include the following items:

- Incoming power to the panel. There may be one or more circuits required, depending upon the number of pumps and local codes.
- Phone line or high-speed internet line to the modem in the control panel (for TCOM remote telemetry control panels).
- Wiring from the control panel to the recirculation pumps and floats.
- Wiring to the ventilation fan assembly (if applicable).
- Wiring to heater, discharge pumps, and floats (if applicable).
- Conduit seal next to the splice box to provide a barrier for gasses and liquids between the conduit and the splice box.

NOTE: Control panels should be protected from direct sunlight to avoid excessive temperatures in the panel and to minimize ultraviolet degradation of the panel enclosure over time. If possible, install the panel under a protective covering and mount it on weather-resistant material and supports.

After you have installed the panel, verify proper connections and test the pumps and floats to make sure they are operating as indicated in the engineering plans and wiring diagrams.

Step 9: Connect Transport Lines to Pods

IMPORTANT: Flush all transport lines before connecting to the pod's inlet coupling.

Remove the red protective plug from the 1½-inch (nominal size) inlet coupling that is flush with the exterior of the pod. Install the transport line from the distributing valve to the inlet coupling.

Exposed PVC pipe should be painted with a UV resistant paint for protection against ultraviolet rays.

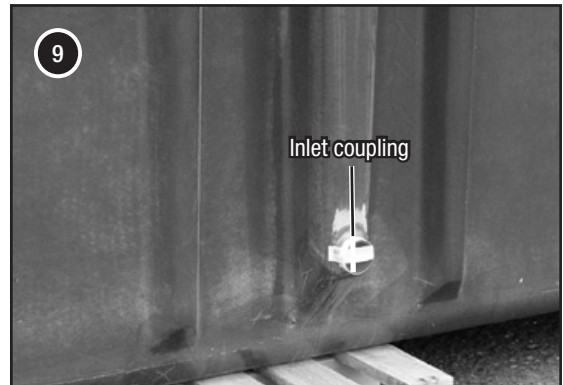

View from outside of pod

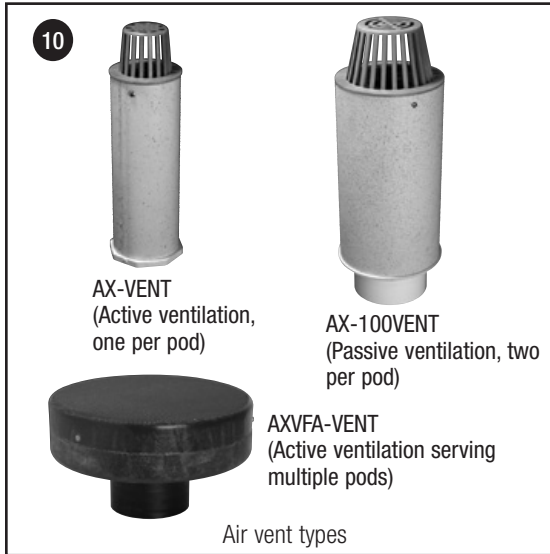

Step 10: Install Air Ventilation Lines

AX100 systems can be designed using one of two ventilation methods — active or passive — and one of three different kinds of vents. Refer to the engineering plans for the correct method and vents to use.

Active or forced ventilation systems require a fan, which is enclosed within the Vent Fan Assembly. An active ventilation system can be designed with one of the following air vents:

- A single, common air vent (AXVFA-VENT) that serves multiple pods, or
- A separate air vent (AX-VENT) for each pod

If the ventilation system uses a heater, a single common air vent will be used, because the heater is within the Vent Fan Assembly.

Passive ventilation systems do not use a fan and require two passive air vents (AX-100VENT) for each pod – one at the filtrate outlet and one at the opposite end of the pod.

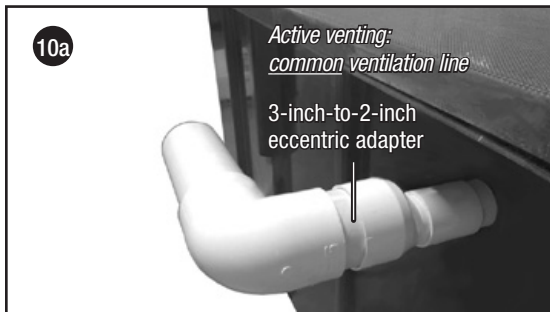

Step 10a: Active Ventilation System

Single Common Air Vent and Single Common Ventilation Line

(This method is for bermed systems only.)

NOTE: To ensure that condensed moisture does not inhibit ventilation, use a 3-inch-to-2-inch eccentric adapter between the pod and the common vent line, installed to allow condensed moisture to flow back into the pod. Make sure that ventilation lines slope back toward the pod and do not sag.

Active venting: common air vent for all pods

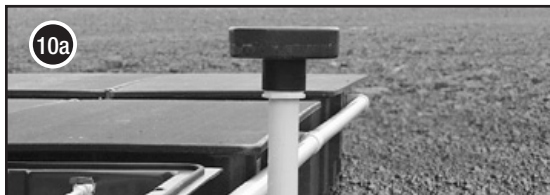

Using 3-inch (nominal size) pipe, plumb the air ventilation line to the 2-inch (nominal size) fitting that protrudes through the pod wall on the end of the pod opposite the filtrate outlet coupling. After you have installed the last AdvanTex pod on multipod systems, install the AXVFA-VENT. The vent may be painted if another color is desired.

Step 10b: Active Ventilation System

Separate Air Vents

(This method is for either bermed or exposed systems.)

Connect the air vent (AX-VENT) to the 2-inch (nominal size) fitting that protrudes through the pod wall on the end of the pod opposite the filtrate outlet. Repeat for each additional pod.

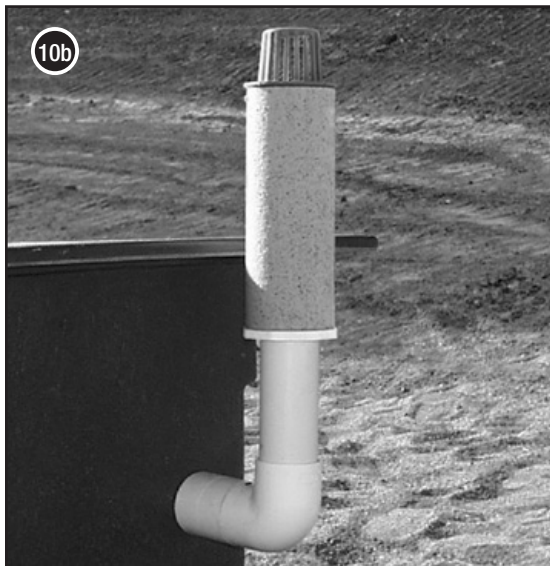

Active venting: separate air vent for each pod

Step 10c: Passive Ventilation System

Two Passive Air Vents per Pod

(Pods must be specifically ordered for passive venting. This method is for either bermed or exposed systems.)

Connect the first passive air vent (AX100-VENT) at the filtrate return tee fitting. Then connect the second passive air vent (AX100-VENT) to the 4-inch (nominal size) fitting that protrudes through the pod wall on the end of the pod opposite the outlet. Repeat as needed for additional pods.

Note: To promote air flow through the pod, place the second passive air vent at least two feet higher than the first one.

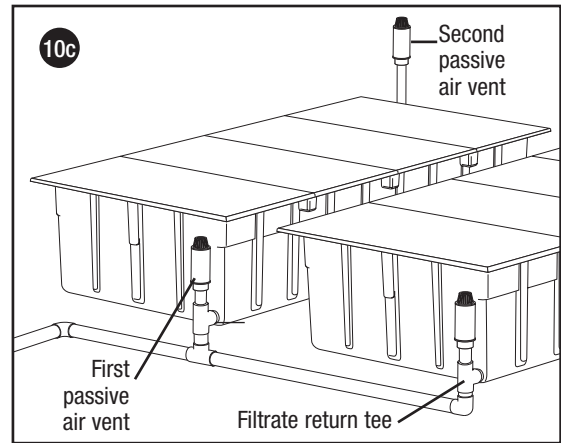

Passive venting

Step 11: Backfill Installation

NOTE: Since AX100 pods are suitable for exposure to UV, backfilling might not be required. Refer to your engineering plans for details. Pods may be bermed, but the bottom of the pod should be no more than 9 inches (230 mm) below the natural grade.

Step 11a: Backfill the excavation. Follow the tank manufacturer’s guidelines for backfilling the tanks. The design should specify backfill material and anti-buoyancy measures.



Step 11b: If the engineering plans specify berming, backfill and compact around each AdvanTex pod in maximum 12-inch (300-mm) lifts. Confirm that all lid fasteners are secured before backfilling. To avoid distorting the shape of the pod, do not overcompact the berm material. Native material is acceptable if it has no large (> 2 inches or 50 mm in diameter) or sharp rocks that may damage the pod walls. If native material is not usable, backfill with sand or pea gravel. Make sure the top of the filter is exposed at least 3-4 inches (75-100 mm) above final grade.



Step 11c: Slope the ground away from the pods to prevent surface water from ponding on or around them. If ground or surface water is a concern, place curtain drains around the treatment area.

Step 11d: Inspect the entire installation for exposed PVC pipe. Paint all exposed PVC pipe with UV-inhibiting paint for protection against ultraviolet light.

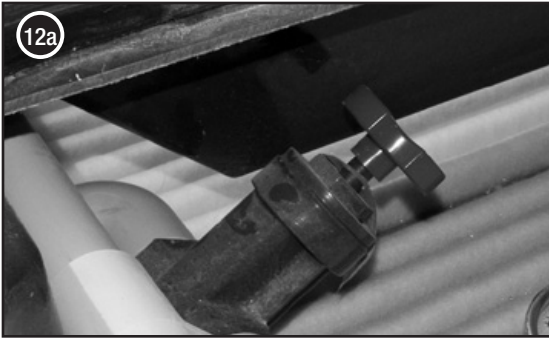

Open manifold valve

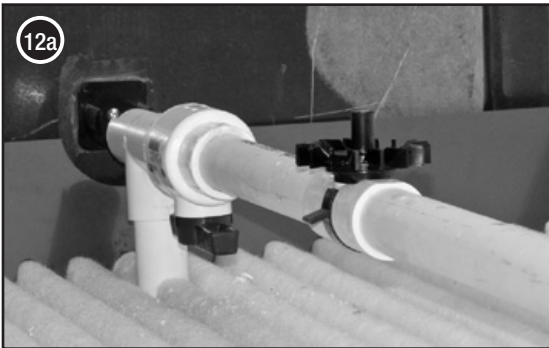

Open outlet valve and flush laterals



Install pressure gauge



Pod prepped for service

Step 12: Prepare Pod for Operation

Before placing the pod in service, use the recirculation pump to flush debris out of the pod's manifold and laterals. Turn off the recirculation pump when you are finished flushing.

Step 12a: Open the manifold valve and make sure all of the laterals are turned so the spray nozzle turbines are pointed up. Open the outlet valves on the laterals. Flush the manifold and laterals with water.

NOTE: A pressure gauge is shipped with the system. The gauge is not intended for permanent installation in the pod. If the gauge is left in the pod, the pod's atmosphere will damage it. Only install the gauge before pressure-testing the system. Remove the plug from the nipple before installing the gauge. Do not overtighten the gauge on the nipple. Remove the gauge and replace the plug in the nipple when you are finished pressure testing.

Step 12b: Close the outlet valves on the laterals. Turn all laterals so the spray nozzle turbines are pointed down. Install the pressure gauge. Pressurize the manifold and laterals to 3 psi (20.7 kPa) and check the nozzles for square spray patterns to the edges of the splash guards, but not over them. Adjust the manifold pressure as needed to bring the patterns to the edges of the splash guards.

Step 12c: Remove the pressure gauge. Leave the nozzles pointed down. The pod is now prepped for service.

Step 13: Prepare for System Start-Up

IMPORTANT: Make sure these items have been completed before scheduling an Orenco representative for system start-up:

- All plumbing connections have been completed and tested.
- All electrical connections have been completed and tested.
- A working, dedicated phone line or high-speed Internet line has been connected to the control panel (if a remote telemetry panel is being used) to allow remote monitoring and control.
- All tanks have been successfully tested for watertightness.
- Water level in all recirculation tanks is set to above the 100% discharge level.

An Orenco representative will perform the system start-up, going through a comprehensive checklist to guarantee your commercial AdvanTex Treatment System is in working order. In addition to logging project and system information, the Orenco representative will verify proper installation of components including, but not limited to, the following checklist items:

Primary Treatment System

- Septic Tanks
- Septic Tank Pumping Equipment
- Septic Tank Controls
- Grease Tanks

Secondary Treatment System

- Recirc/Blend Tanks
- Recirc/Blend Tank Pumping Equipment
- Recirc/Blend Tank Controls
- Distributing Valve Assembly
- Ventilation Fan System
- AdvanTex Filter Operation

Dispersal System

- Dosing Tank
- Dosing Tank Pumping Equipment
- Dosing Tank Controls
- Distributing Valve Assembly

The Orenco representative will inspect the AdvanTex System for proper installation, test all components, document initial performance values, and verify that all system components are functioning properly.

The engineer, contractor, electrician, and operator, as well as the owner and inspector/regulator (recommended), should all be present at system start-up.



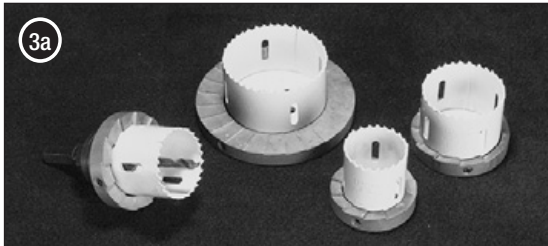
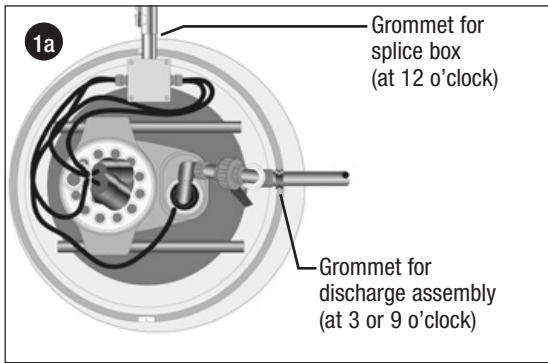

Appendix: Grommet Installation Instructions

Step 1: Use the plans or drawings when marking the location of riser penetrations. If no plans are available, use the drawing at left as a general guide for locating riser penetrations.

Step 2: Mark the riser for location of the grommets.

Note: When drilling Perma-Loc™ risers, try to avoid cutting through the pipe seam — the extra thick rib — unless it is unavoidable.

Step 3: Drill the hole(s) in the riser ...

Step 3a: Using an Orenco RKHS Hole Saw ...

Use a correctly sized RKHS hole saw and a drill of at least 18 volts to cut the hole and grind the ribs down until there is a flat, smooth surface for installing the grommet. Do not grind too deeply into the riser — about 1/16 inch is sufficient.

Step 3b: Using a Standard Hole Saw ...

1. Use a 4-inch (100-mm) grinder or cutting tool to notch the ribs through to the wall of the riser in an area about 1 inch (25 mm) larger than the diameter of the grommet.
2. Use a hammer and chisel to break off the notched ribs.
3. Use a grinder to remove any remaining rib material and make a flat, smooth surface about 1 inch (25 mm) larger than the diameter of the grommet.
4. Use a correctly sized hole saw to cut the hole in the center of the flat, smooth surface.

Step 4: Use a wire brush to clean up the cut; then deburr the edges of the opening with a deburring tool or knife, being careful not to enlarge the opening.

Step 5: Apply a bead of adhesive to the groove in the grommet's outer diameter and firmly press the grommet into the riser penetration.

Grommet Hole Sizing Guide

Grommet size, inches (nominal IPS pipe size)	Hole saw size
1/2	1
3/4	1-1/4
1	1-9/16
1-1/4	1-3/4
1-1/2	2-1/8
2	2-3/4
3	3-7/8
4	5

For more information on grommet dimensions and actual pipe O.D., see the Orenco Technical Data Sheet for grommets, NTD-RLA-PG-1

Notes

Notes

Installation Manual

AdvanTex[®] **AX100 Treatment Systems**

Commercial Applications

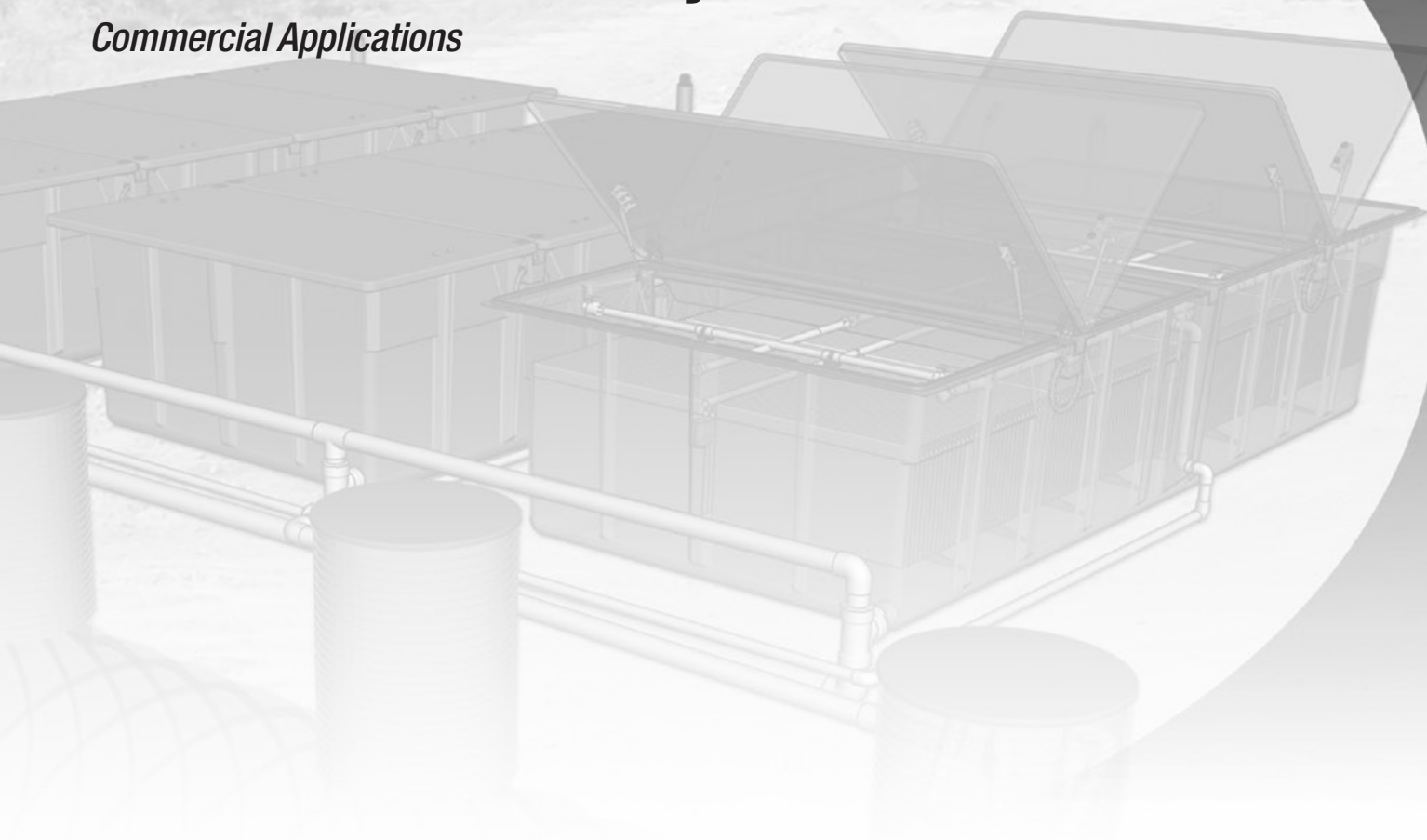

Orengo[®]
Orengo Systems, Incorporated

1-800-348-9843
+1-541-459-4449
www.orengo.com

NIM-ATX-AX-2
Rev. 3.2, © 11/13
Orengo Systems[®], Inc.