

WHITEWATER[®]

Aerobic Wastewater Treatment Unit

"OREGON~ DF SERIES"

INSTALLATION, OPERATION, & MAINTENANCE MANUAL



Delta Environmental[™]
Pentair Water

Revised 5-25-2011

DISTRIBUTOR AND HOMEOWNER NOTES

- 1. The Delta Environmental Products™ Pentair Water Model DF40-M has been tested by NSF International and conforms to ANSI/NSF Standard #40, class 1 effluent requirements. All other DF series models are certified based on provisions in the standard for certification of a series of plants of the same model varying only in rated treatment capacity and materials of construction.
- 2. State and/or local regulations govern the installation and use of individual Aerobic Wastewater Treatment Systems and must be complied with.

Consult your local regulator prior to installation.

HOMEOWNER RECORDS	
S/N: _____	DATE: _____
INSTALLED BY: _____	
DISTRIBUTOR: _____	

NOTICE

This booklet provides operations, installation and warranty information on the **TREATMENT PLANT ONLY**. Other components which you may have, such as dosing equipment, drip irrigation or other components require additional operations booklets and carry separate warranties.

Be sure that you have all of the correct booklets for each of the component pieces in your system.

Contact you installer or call (800) 219-9183.

DELTA ENVIRONMENTAL PRODUCTS™	
PENTAIR WATER	
QUALITY ASSURANCE TAG	
S/N _____	DATE _____
Fiberglass Integrity: Barcol Tested Thickness Verified Clarifier Solid	_____ (Initial)
Water Tested	_____ (Initial)
Metal Integrity: Welds Inspected Paint Adherence Clips/Brackets Intact	_____ (Initial)
Compressor Package Complete: _____	(Initial)
Internal Assembly: Clarifier Intact Air Header Complete & Secured Air Drop Lines Complete & Secured Discharge Tee Assy Center & Level Cover Attached, Sealed & Secured	_____ (Initial)
Component Kit: Air Header Complete & Secured Air Drop Lines Complete & Secured Discharge Tee Assy Secured	_____ (Initial)

Post In A Service/Utility Area

WHITEWATER[®] TREATMENT SYSTEMS **NOTICE**

This home is served by an Individual Wastewater Treatment System. This system will serve you well only if it is properly maintained. Your system is comprised of

Your system is located

You should not build or fill over this area, or allow heavy traffic. Do not allow water to stand over this area, avoid using strong chemicals, cleaning fluids, etc., which will kill helpful bacteria in the system. You should also avoid flushing grease, food scraps, cigarette butts, sanitary napkins, and other inorganic waste down the drain.

You should have your system serviced in accordance with your service contract. Your service technician can advise you if you need more frequent or additional service.

To have your system serviced, or for additional information, call _____ at _____.

All of the details regarding system operation can be found in your homeowner's manual which you should have received at installation. If you did not receive a copy call 1-800-219-9183 and we will send you one at no charge.

Keep A Record Of Service Below:

DATE	SERVICE PERFORMED	SERVICE TECHNICIAN

Delta Environmental Products™ • P.O. Box 969 • Denham Springs, LA 70727 • 1-800-219-9183

THE FOLLOWING SHOULD NOT BE USED OR DISPOSED INTO THE SYSTEM

- Greases, Fats and Oils – Pesticides, Herbicides, or any other toxins.
- Garbage disposal should be used sparingly. Dispose of food waste, grease, etc., in the solid waste bin. Food waste represents additional loading the Aerobic Treatment Plant would have to digest, increasing pump out intervals.
- Paints, household chemicals – automobile fluids – do not discard mop water into the system.
- Non-Biodegradable items such as cigarette butts, disposable diapers, feminine hygiene products, condoms, hair, coffee grounds, rags, paper towels, bandages, etc.
- Wash loads must be spread out over the week. Once a week multiple loads or half loads are not recommended.
- Citrus products, oranges, lemons, grapefruit, etc.
- Additives for septic systems – they do no more harm than good.
- Hydraulic overload due to excessive water from other sources.
- Home Brewery Waste – Strong Medicines, Antibiotics. Anti-Bacteria Soaps should be avoided.
- Strong disinfectants or bleaches. Laundry products such as: Lysol, Pine-Sol, Tidy Bowl, or discharge from water softeners, Drano.
- Recommended detergents are: powdered, low-sudsing, low phosphates and biodegradable, washing soda ingredients such as Gain, Arm & Hammer, Fresh Start, and Dash Bright. Fabric softener dryer sheets are recommended.
- Recommended cleaning products are: Non-chlorine, biodegradable and non-toxic such as Ivory & Sunlight dish washing liquids, Cascade & Sunlight powdered dishwasher detergents, Comet & Biz powdered cleaners, baking soda.

SYSTEMS REQUIRING PUMP OUTS DUE TO THE ABOVE VIOLATIONS ARE NOT COVERED BY THE WARRANTY.

A WORD ABOUT YOUR DELTA AEROBIC WASTEWATER TREATMENT SYSTEM AND HOW IT WORKS

The Whitewater® Aerobic Wastewater Treatment System that you have purchased produces high quality water suitable for various disposal methods. It is used to enhance your on-site wastewater disposal system. You can be proud that in purchasing your Whitewater® System with a minimum amount of maintenance, you can directly contribute to a cleaner, safer environment.

All wastewater treatment systems of this type work by using the bacteria that nature has provided by pumping air into the system, the bacteria grow and thrive in much larger amounts than would occur naturally. The over-population of bacteria speeds up the process of breaking down domestic wastewater this makes it safe to release into the environment. This entire process takes place within the walls of your specially designed, self-contained Whitewater® Treatment System.

Your Whitewater® System is made up of an outer mixing chamber and center settling chamber. Raw unsettled domestic wastewater enters directly into the mixing chamber. Mixing is accomplished by air passing from the air pump to the air drop-lines located around the outer wall of the mixing chamber. The design is such that solids remain in suspension with a general flow pattern up the outer plant wall, then down the outside of the settling chamber when the air pump is on. This flow pattern allows a quiet condition in the settling chamber.

The mixed liquid enters the hopper-shaped settling chamber at the bottom and travels upward toward the discharge pipe. The quiet condition allows solids to settle down and re-enter the mixing chamber.

The result of this process is a clear, odorless discharge, which meets or exceeds state water quality standards.

By following the few simple steps that you find in this manual, your Whitewater® System will provide you with years of service and the knowledge that you are doing your part to protect our ground water, lakes, rivers, and streams.

Whitewater® is a registered trademark of Delta Environmental Products™ a Pentair Water Company

HOMEOWNER CARE AND OPERATION INSTRUCTIONS

The Whitewater® System has been designed and built to provide long term, reliable and efficient service.

Once the unit has been installed, (see installation instructions) the unit will operate with a minimum amount of attention.

Please reference the system's Data Plates that are located on aerobic tank 24" cover, air pump, and the alarm panel in the event that a problem arises or service is required.

The following should be accomplished as checks for system failure:

Daily - Observe the warning device, which comes on when the power to the air pump has been interrupted or when the air supply system has malfunctioned. If the alarm is activated, check for a blown fuse or thrown circuit breaker. Check air pump to be sure it is operating. Once accustomed to the soft humming sound of a properly operating unit, any unusual noise is an indication of malfunction. If an unusual noise is detected or total failure is observed then contact your Authorized Delta Service Provider.

Weekly - Check the treatment plant for offensive odor.

If any problems develop in the daily or weekly sections contact your Authorized Delta Service Provider.

Every
3 Months - **The air filter on the air pump should be cleaned.** Rinse with warm water if necessary. (See installation instructions). Do not use oil or other solvents.

Note - To keep maintenance to a minimum and ensure high effluent quality, the following items should not be permitted to enter the system.

ITEMS NOT PERMITTED IN THE SYSTEM

- Strong disinfectants or bleaches, other than small amounts normally utilized in day to day cleaning and laundry (be conservative). Laundry detergents recommended for use are low-sudsing, low phosphates and biodegradable, such as Gain, Arm & Hammer, All, Fresh Start, Dash Bright.
- Discharge from water softener
- Any type of oils, greases, or other chemical wastes
- Disposable baby diapers and wipes
- Sanitary napkins, condoms or other similar items
- Hair, bandages, rags, or string
- Latex, plastic, or metallic objects
- Coffee grounds or cigarette butts
- Mud or sticks
- Paper towels, napkins, or Kleenex
- Tidy Bowl type products
- Beer waste or any other rich liquids
- Garbage disposal should be used sparingly, not as a method of disposing all solid food waste. In order to ensure good plant operation, waste should be disposed of in the garbage container.

The Whitewater® System is designed to handle domestic wastewater and nothing else should go into it. For anything other than domestic wastewater contact: Delta Environmental Products™ a Pentair Water Company

WARNINGS

1. The proper operation of this or any other home sewage system depends upon proper organic loading and the life of the microorganisms inside the system. Delta is not responsible for the in-field operation of a system, other than the mechanical and structural workings of the plant itself. We cannot control the amount of harsh chemicals or other harmful substances that may be discharged into the system by the occupants of a house hold we can only provide a comprehensive owner's manual that outlines substances that should be kept out of the system.
2. Hydraulic overloading (flows in excess of design flow) may cause the sewage treatment system not to perform to the fullest capabilities.
3. Ants have been shown to be destructive to the air pump. Regular care should be taken to prevent infestation of ants near the system. Damage or destruction by ants is not covered under manufacturer's warranty.
4. Your State or Local Health department may require other pieces of equipment to function separately or in conjunction with equipment manufactured by Delta Environmental Products™. Delta Environmental Products™ is not responsible for the mechanical or electrical safety of equipment it does not manufacture or supply with its aerobic treatment units. Particular care should be used in evaluating the electrical or mechanical safety of equipment manufactured by others. This may include but not be limited to electrical control panels or air pumps.
5. If electrical service has not been installed for checking air distribution system during installation, and if an extension cord is used to test the air pump, never leave the extension cord plugged in. Remove it after testing is completed.
6. Due to a possible fire hazard, DO NOT plug into service equipment on power pole and DO NOT use extension cords. All electrical work performed by the installer or others must be in accordance with the National Electrical Code and Local Codes.
7. The operation & maintenance outlined in this manual applies to normal operating conditions. Extreme conditions such as frigid cold temperature, extreme heat and high altitudes may effect the operation and maintenance of this unit. Consult Factory regarding these extreme conditions.

WARNING

**Failure to Properly Secure the
Top May Result in a Serious
Health or Safety Hazard.**

SOLIDS REMOVAL

The **Whitewater® Treatment System** is designed to provide years of trouble free operation.

Determination of the need for solids removal can be done through a simple test. A one quart sample should be pulled from the aeration tank and can be done so through the 4" sample port. Allow the sample to settle in a clear one quart jar for thirty minutes. If the solids content exceeds 60% of the total volume after settling, the treatment plant should be pumped out. Call your local authorized sewage disposal service to have the tank contents pumped out and disposed of properly.

The method of pumping out should be as follows:

- Remove any floating solids by skimming.
- The air pump must be operating to keep the solids in suspension.
- Pump out two thirds of the tank volume with the suction pipe opening being placed at the tank bottom.

After the pump-out process is complete, fill the tank with fresh water to normal operating level.

Refer to the Installation Instructions to get the treatment plant back into operation.

Should indication of improper operation be observed at any point in time, contact your local distributor.

NOTE: THE COST ASSOCIATED WITH PUMPING THE TREATMENT SYSTEM IS NOT COVERED UNDER WARRANTY AND IS NOT INCLUDED IN THE SERVICE POLICY.

SEASONAL USE GUIDELINES OF WHITewater AEROBIC TREATMENT UNIT

These guidelines are for conditions as outlined below and apply for systems that are not in use for periods of time indicated. Site conditions not covered by the following must be forwarded to Delta for recommended guidelines to meet the particular site conditions.

1. System not in use for more than one month and less than three months. Electrical power is left on and there are no frost conditions.
 - Leave air pump on and system running.
2. System not in use more than three months. Electrical power is turned off and there are not frost conditions.
 - While system is operating with the air pump on, remove all material and liquid from tank.
 - Refill with clean water.
 - Turn off air pump.
3. System not in use more than three months. Electrical power is on and there are not frost conditions.
 - Leave air pump on and system running.
 - OR, while system is operating with the air pump on, remove all material and liquid from tank.
 - Refill with clean water.
 - Turn off air pump.
4. System not in use. Electrical power is turned off and there are frost conditions.
 - While system is operating with the air pump on, remove all material and liquid from tank.
 - Turn off air pump.
 - If high ground water is present, fill with clean water.
 - If no ground water is present, leave tank empty.

UNDER NO CIRCUMSTANCES SHOULD THE AIR PUMP BE TURNED OFF FOR MORE THAN A FEW DAYS WITHOUT REMOVING TANK CONTENTS!!

SAMPLING REQUIREMENTS

Whitewater® aerobic treatment units, in order to meet the State of Oregon treatment standard 1 must provide the following effluent quality of:

30-day average Biochemical Oxygen Demand (BOD₅) of less than 20 mg/l (or ppm),
30-day average Total Suspended Solids (TSS) of less than 20 mg/l (or ppm),

Taking Effluent Samples:

Samples must be taken in the effluent discharge line, in the effluent dosing tank or after the chlorine contact tank. We recommend allowing the effluent to flow through the discharge pipe for a minimum of 2 minutes before taking the sample. This will allow any solids to be flushed out that might have accumulated in the discharge pipe. Please find attached drawing of a Sample Port.

SAMPLING SHOULD BE TAKEN BY A LOCAL CERTIFIED TESTING LABORATORY OR BY FOLLOWING THEIR PROCEDURES. THE FOLLOWING RECOMMENDED GUIDELINES MAY BE USED IF LOCAL PROCEDURES ARE NOT AVAILABLE.

1. Biochemical Oxygen Demand (BOD)

Samples for BOD analysis may degrade significantly during storage between collection and analysis, resulting in low BOD values. Minimize reduction of BOD by analyzing the sample promptly or by cooling it to near-freezing temperature during storage. However, even at low temperature, keep the holding-time to a minimum. Warm the chilled samples to 20°C before analysis; some storage time can be used to accomplish this conveniently.

Grab Samples: If analysis is begun within 2 hours of collection, cooling is unnecessary. If analysis is not started within 2 hours of sample collection, keep sample at or below 4°C from the time of collection. Begin analysis within 6 hours of collection; when this is not possible because the sampling site is distant from the laboratory, store at or below 4°C and report length and temperature of storage to the Lab. In no case, start analysis more than 24 hour after grab sample collection. When samples are to be used for regulatory purposes, make every effort to deliver samples for analysis within 6 hours of collection.

2. Total Suspended Solids (TSS)

Use resistant-glass or plastic bottles, provided that the material in suspension does not adhere to container walls. Begin analysis as soon as possible because of the impracticality of preserving the sample. Refrigerate sample at 4°C to minimize microbiological decomposition of solids.

3. Phosphorous

If phosphorus forms are to be differentiated, filter samples immediately after collection. Preserve by freezing at or below -10°C. Add 40 mg HgCl₂/L to the samples, especially when they are to be stored for long periods. Do not add either acid or 2CHCl₃ as a preservative when phosphorus forms are to be determined. If total phosphorus alone is to be determined, add 1 mL concentration HCL or freeze without any additions.

Do not store samples containing low concentrations of phosphorus in plastic bottles unless kept in a frozen state because phosphates may be adsorbed onto the walls of plastic bottles.

Rinse all glass containers with hot diluted HCL, then rinse several times in distilled water. Never use commercial detergents containing phosphate for cleaning glassware used in phosphate analysis.

4. Ammonia Nitrogen

Most reliable results are obtained on fresh samples. Destroy residual chlorine immediately after sample collection to prevent its reaction with ammonia. If prompt analysis is impossible, preserve samples with 0.8 mL concentration H₂SO₄/L sample and store at 4°C. The pH of the acid-preserved samples should be between 1.5 and 2. Some wastewater may require more concentration H₂SO₄ to achieve this pH. If acid preservation is used, neutralize samples with NaOH or KOH immediately before making the determination.

SAMPLE PROCEDURES:

1. PRIOR TO TAKING SAMPLE HAVE WHITEWATER PLANT DISCHARGE EFFLUENT FOR UP TO 4 MINUTES BY FLUSHING TOILETS AND/OR USE GARDEN HOSE TO FLUSH OUT SAMPLE PORT.
2. INSERT SAMPLE COLLECTING BOTTLE TO COLLECT ONLY EFFLUENT WHICH IS CASCADING OVER THE CASCADING EDGE.
3. HANDLE, STORE, AND TRANSPORT SAMPLES AS SPECIFIED BY POLICIES AND PROCEDURES PROVIDED BY THE TESTING LABORATORIES.

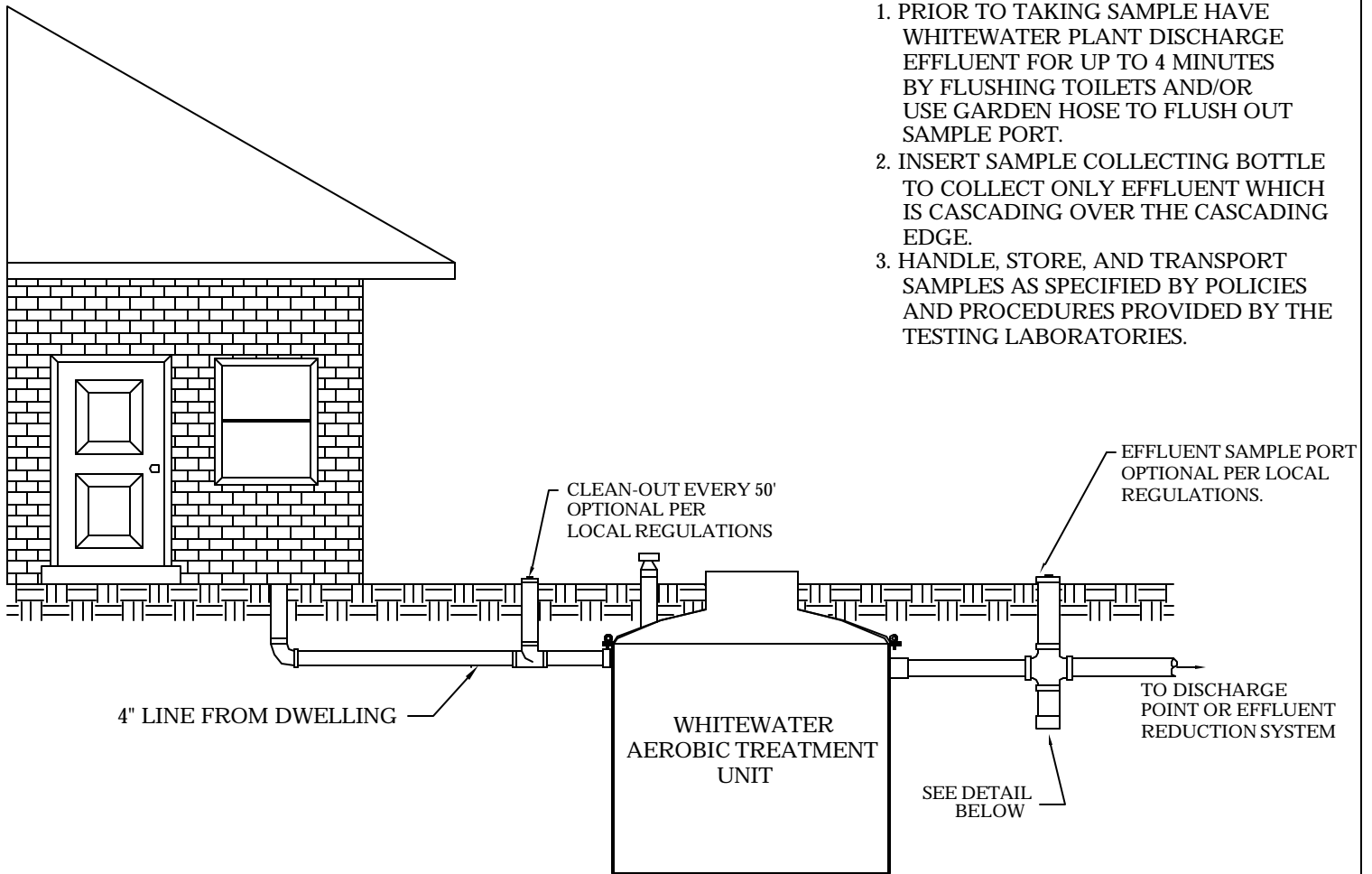

EXAMPLES OF SAMPLE PORTS

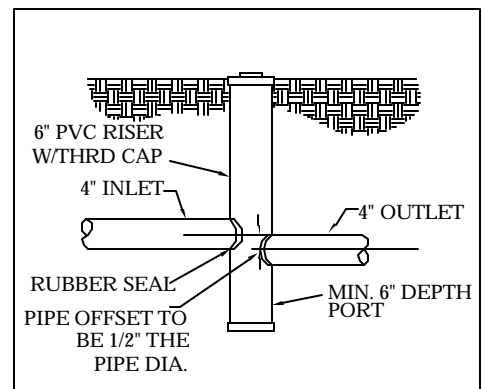
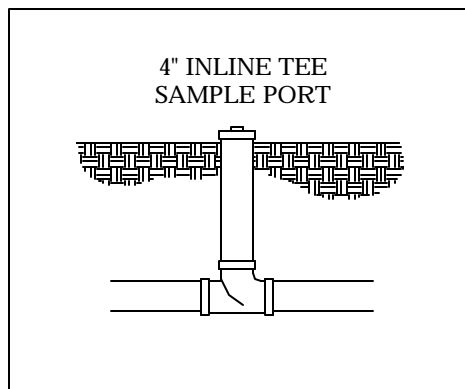
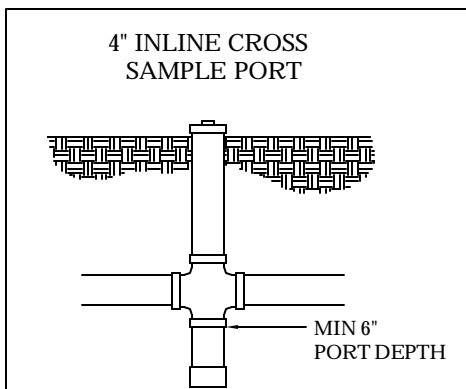

DELTA ENVIRONMENTAL PRODUCTS
P. O. BOX 969 DENHAM SPRINGS, LA 70727

SAMPLE PORTS

DWN BY:
C.RACHAL

DATE:
4/16/07

SCALE:
N.T.S.

DWG. NO.:
CRT361

INSTALLATION INSTRUCTIONS ONLY FOR USE BY CERTIFIED, LICENSED INSTALLER

Note: Maximum burial depth is two feet from tank flange to surface.

Please refer to drawing on page 18.

These systems will need to be preceded by a septic tank approved for use in Oregon. All tank volumes will be as required in OAR 340-071

1. Prepare an excavation, having a diameter approximately one foot larger than the tank and a depth that will allow approximately 3 inches of the inspection port to extend above normal ground level. Backfill with a 6 inch layer of sand or gravel if otherwise unable to provide a smooth, level, compact base. We recommend that the hole be roped off in some fashion to prevent injury to passersby.
2. Utilizing lifting lugs provided, place the plant in the excavation so that the inlet and outlet line up with the sewer piping. The inlet line should slope down toward the plant and the outlet line should slope down away from the plant. The plant should be level within 1/2 inch, edge to edge.
3. Position inlet and outlet lines and make connections as necessary, depending upon the construction materials. The inlet line should be inserted and glued into the inlet elbow and the discharge line should be inserted and glued into the outlet coupling. Note: Open inspection port and make sure discharge tee assembly is level and centered in clarifier prior to attaching discharge piping. Fill the tank with water until water flows from the discharge before backfilling. Back fill around the treatment plant up to the bottom of the discharge connections.
4. Do not install the air pump(s) in a low lying area where water may accumulate. The air pump should be installed near the control panel and within 100 ft. of the tank. Air pump can be installed outdoors or in a clean, well ventilated area, such as a tool room, garage, etc. **If the linear air pump is to be installed in an additional enclosure, the enclosure must be approved by Delta in writing.**
5. Mount the control panel in an area such that the alarm can be heard and be readily observed. A 3-wire grounded GFI circuit, are required for safety. Install a disconnect switch near the panel to visually disconnect the control panel from the power source. All electrical work shall be done according to NEC and local code requirements. The control panel must be grounded. Connect the source ground wire to the ground location in the panel. **Note: The visual alarm must be conspicuous at a distance of 50 feet and audible alarm must be discernable at a distance of 50 feet.**
6. The control panel is rated for indoor and outdoor use and contains a fuse for the air

pump. An electrical malfunction in the air pump or wiring to the air pump will cause the fuse to blow. The control panel also contains a pressure switch with a visual and audible alarm. Loss of air pressure caused by air pump system malfunction or a high water level in the treatment plant will cause the alarm to sound and light to illuminate.

7. Attach control panel to suitable mounting surface using all four mounting holes on back of box. Use proper screws of sufficient length to insure a secure and permanent mounting.
8. Control panel CP2056 is rated for outdoor service, however, do not place it where it can be immersed in rising water or where run-off water such as from a roof will fall on it. Do not mount it where it is subject to wetting from sprinklers, hoses, etc.
9. The control panel must never be connected to a circuit that is not properly grounded. Never connect the unit to a non-grounded circuit. If there is doubt, have a qualified electrician check for proper grounding. The control panel must be connected to a 20 amp maximum electric source equipped with a ground fault interrupter (GFI) circuit breaker. A standard circuit breaker can be replaced with a GFI circuit breaker which can be obtained from almost any store that sells electrical supplies.
10. After the control panel is properly mounted, connect conduit and install wiring as shown on drawings bound herein.
11. Install the float switch wire from the control panel to the treatment plant. Wire can be direct burial type UF 600 volt or can be installed in schedule 40 pvc conduit. Use type THWN, 600 volt if installed in conduit. Wire must be buried in accordance with NEC table 300-5. If in doubt, bury 24" deep. Keep sufficient distance or depth from air line to avoid confusion of pipes or damage to wiring during installation or repair of air piping. Connect to the float switch normally open contacts using underground rated compound filled wire nuts.
12. Connect the pressure air tubing to the 1/8" barb-fitting directly to the 3/4" airline or directly to the compressor. Refer to illustrations in Appendix B for appropriate air tubing connections.
13. Install 3/4" schedule 40 PVC piping between air pump and treatment unit. A minimum of 12" ground cover is recommended.
14. All tanks must be filled with clean water for testing purposes.
15. Turn power on to control panel. Air pump should start.
16. Check air piping joints for leakage using a soapy water solution. Repair if necessary and then carefully backfill air line and inlet and discharge piping and cover plant to

grade level.

17. Re-check water level in the tank.
18. Plant is ready to receive incoming sewage. No special start-up procedures are required. The process is naturally occurring and does not require any special additives.
19. Test alarm circuit by momentarily squeezing air tubing and allowing air pressure to decrease. This should take a few minutes. Alarm should occur. Release air tubing and alarm should stop. Lift float in tank to horizontal position. Alarm should occur. Release float. Alarm should stop. The audible alarm can be turned off by flipping the toggle switch on the panel front door to the left.
20. Close cover on control panel and lock if necessary.
21. In the event that a fuse blows, replace with time delay or slow blow, 125 volt minimum voltage rating and the same amp rating as the existing fuse.
22. The distribution of air to all droplines must be uniform. If the air flow is not evenly distributed, check the air pump or the main air line.
23. Spend time with your customer whenever possible. Review operation instructions. Be sure that the customer has a manual to keep. This saves valuable time avoiding return visits.
24. Retain these instructions for future reference.
25. **WARNING:** Control panel contains high voltage and must only be installed and serviced by qualified personnel.
26. **WARNING:** DF series fiberglass construction is furnished with a 24" polyethylene cover with gasket that is securely fastened to the tank lid. The cover must be placed six inches above grade to promote surface runoff.

DELTA ENVIRONMENTAL PRODUCTS RECOMMENDED INSTALLATION PROCEDURE

1. EXCAVATION:

Dig hole from the side for accurate sizing. This reduces the bridging distance between the tank and undisturbed soil and provides good support for inlet and outlet pipes. The bottom of the hole should be undisturbed and level. If leveling is necessary due to over excavation, use sand for fill.

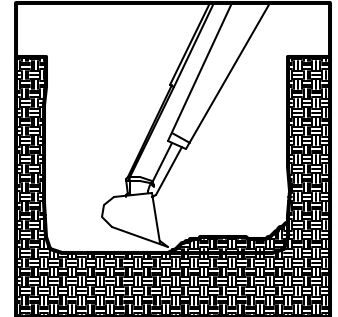

NOTE: Never place tank directly on rock. place at least six inches of sand or gravel bedding between the tank and rock surface.

2. TANK PLACEMENT:

Use the back hoe to set the tank. Lifting lugs are furnished to lift the tank.

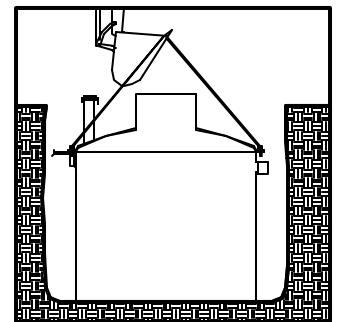

CAUTION: A small amount of soil or sand should be used around the bottom of the tank to hold it in place. Sand is best. If excavated soil is used, tamp it underneath the tank to provide a good base.

3. FILL TANK WITH WATER:

Place hose in six inch riser. Begin filling tank with water.

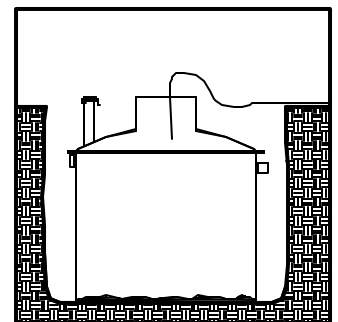

DELTA ENVIRONMENTAL PRODUCTS
P. O. BOX 969 DENHAM SPRINGS, LA 70727

INSTALLATION PROCEDURE

DWN BY:
C.RACHAL

DATE:
4/16/07

SCALE:
N.T.S.

DWG. NO.:
DEP034B

4. GFI CONTROLS AND AIR PUMP

Install duplex or quadruple GFI or GFI protected receptacles at the selected location of the air pump. Mount control panel and install fittings, tubing and piping to tank location.

CAUTION: Do not plug anything but the air pump into the control panel.

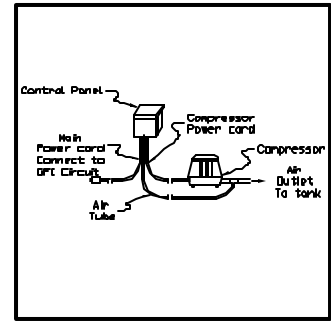

5. INLET/OUTLET AND AIR CONNECTIONS

Properly make solvent cemented inlet, outlet and air connections.

6. FILLING THE TANK

Finish filling tank with water until it drains out of outlet. Begin backfilling with natural soil or a good back fill material.

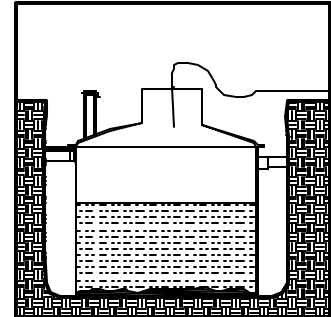

7. AIR DISTRIBUTION

Turn the air pump on and check all air connections and piping for air tightness. Observe air/water mixture through 4" riser.

NOTE: If electrical GFI receptacle has not been installed, for checking air distribution system during installation, use an extension cord to run the air pump. Never leave the extension cord plugged in. Remove it after inspection is completed.

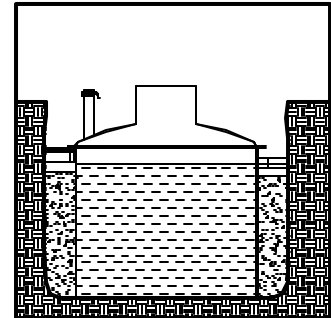

WARNING: Possible Fire Hazard

Do Not plug into main service equipment on power pole.

Do Not use extension cords

8. FINAL BACK FILLING

Back fill should be mounded above grade slightly to allow for settling. Tamp the back fill beneath the inlet, outlet and air piping to provide good support.

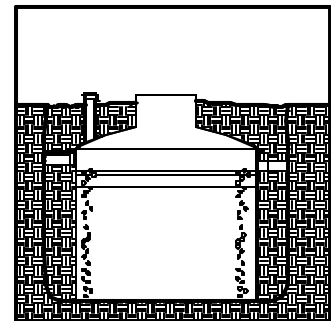

DELTA ENVIRONMENTAL PRODUCTS
P. O. BOX 969 DENHAM SPRINGS, LA 70727

INSTALLATION PROCEDURE

DWN BY:
C.RACHAL

DATE:
4/16/07

SCALE:
N.T.S.

DWG. NO.:
DEP034A

9. TRIM INSPECTION RISERS

Trim inspection risers to proper length. The 4" aeration inspection riser also serves as a vent for the tank.

Caution: The bottom of the 4" aeration riser must be above the water level for both visual inspection and ventilation. Both of the optional 6" and 4" top caps must be above ground level to prevent ground water from entering the risers.

Caution: Care must be taken not to push the optional 6" Clarifier Inspection Riser down too far. This may cause damage to the effluent discharge tee assembly and the clarifier.

Caution: Maximum burial depth - 2 feet from top of tank flange with dome or 24" manways.

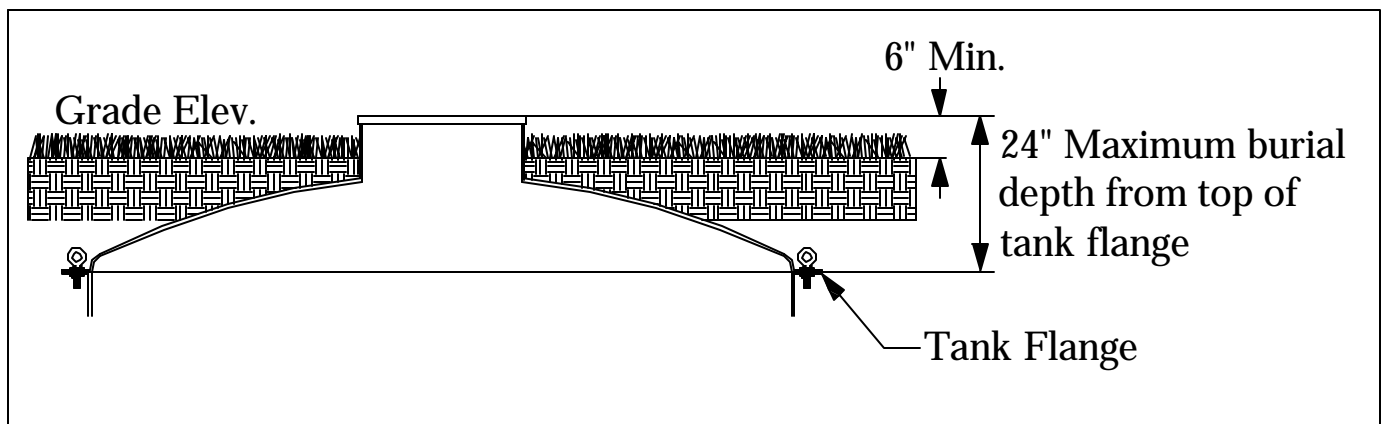
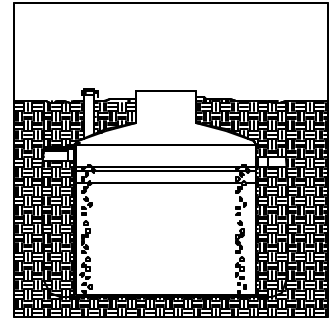

DELTA ENVIRONMENTAL PRODUCTS
P. O. BOX 969 DENHAM SPRINGS, LA 70727

INSTALLATION PROCEDURE

DWN BY:
C.RACHAL

DATE:
4/16/07

SCALE:
N.T.S.

DWG. NO.:
DEP034

DELTA ENVIRONMENTAL PRODUCTS PUMP OUT PROCEDURE

1. Determine the amount of MLSS by using a "Sludge Judge" type sampler through the 4" vent/sample port riser.

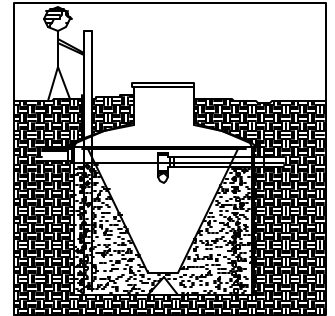

2. Leave the air compressor for the ATU running.

3. Insert vacuum hose into the main access riser. Skim off any floatable solids on the surface of the clarifier and lower to the bottom of the clarifier.

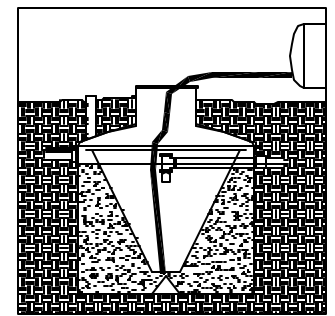

Caution: Care must be taken not to damage the discharge tee assembly.

4. Pump out 80 to 90 percent of the ATU. Then remove the vacuum hose.

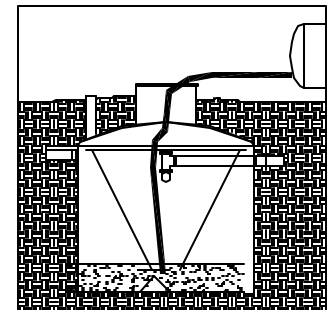

5. Insert a water hose into the main access riser. Wash down the clarifier walls and partially refill the ATU with clean water.

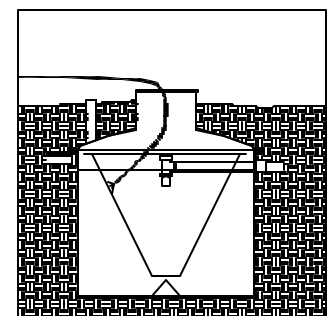

6. Repeat step 3 and refill the ATU with clean water.

*Never leave tank empty.

*Always use licensed pumpers/haulers for this task.



DELTA ENVIRONMENTAL PRODUCTS
P. O. BOX 969 DENHAM SPRINGS, LA 70727

PUMP OUT PROCEDURE

DWN BY:
C.RACHAL

DATE:
4/16/07

SCALE:
N.T.S.

DWG. NO.:
DEP033

State of Oregon

ATT Malfunction Prevention Configurations

Configuration 1 – Septic tank/DF50FF – 500 GPD ATU with Delta’s DEP 24.5115V 24” Effluent Pump Station

- Delta’s CP 2056 Electrical Control panel with DEP 24.5115V24” secondary effluent pump shut down feature.
- Upon air compressor failure or high water alarm status, unit’s controller will lock out secondary effluent pump operation to the disposal field. Pump lock out feature will stay until reset by service provider. Alarm lights and audible alarms will indicate which alarm is occurring including high level in Delta’s DEP 24.5115V 24” effluent pump station.

Configuration 2 – Septic tank/DF50FF - 500 GPD ATU with primary effluent pump configuration effluent pump assembly DEPIT.5115V.

- Delta’s CP 2056 Electrical Control panel with DEPIT.5115V primary pump shut down feature.
- Upon air compressor failure or high water alarm status, unit’s controller will lock out primary effluent pump operation to DF series unit. Pump lock out feature will stay until reset by service provider. Alarm lights and audible alarms will indicate which alarm is occurring either high level in primary tank or DF50FF ATU

Configuration 3 – Septic tank/DF50FF – 500 GPD ATU and State approved dosing tank configuration. Dosing tank shall meet state of Oregon OAR 340-071-220(6) regulations.

- Delta's CP 2056 Electrical Control panel with DEP .5115V effluent pump shut down feature.
- Upon air compressor failure or high water alarm status, unit's controller will lock out secondary effluent pump operation to disposal field. Pump lock out feature will stay until reset by service provider. Alarm lights and audible alarms will indicate which alarm is occurring including high level in dosing tank.

Delta's Electrical Controller Specifications - CP 2056

- Visual and audible signals are noticeable at 50 feet from system. As Certified by NSF International. Audible is between 70 and 90 dba at 5 feet. As certified by NSF
- Visual and Audible signals are separate from mechanical functions and remain activated during malfunctions except when there is loss of electrical power to facility.
- A visible label with instructions for obtaining service will be permanently attached to Electrical Controller.

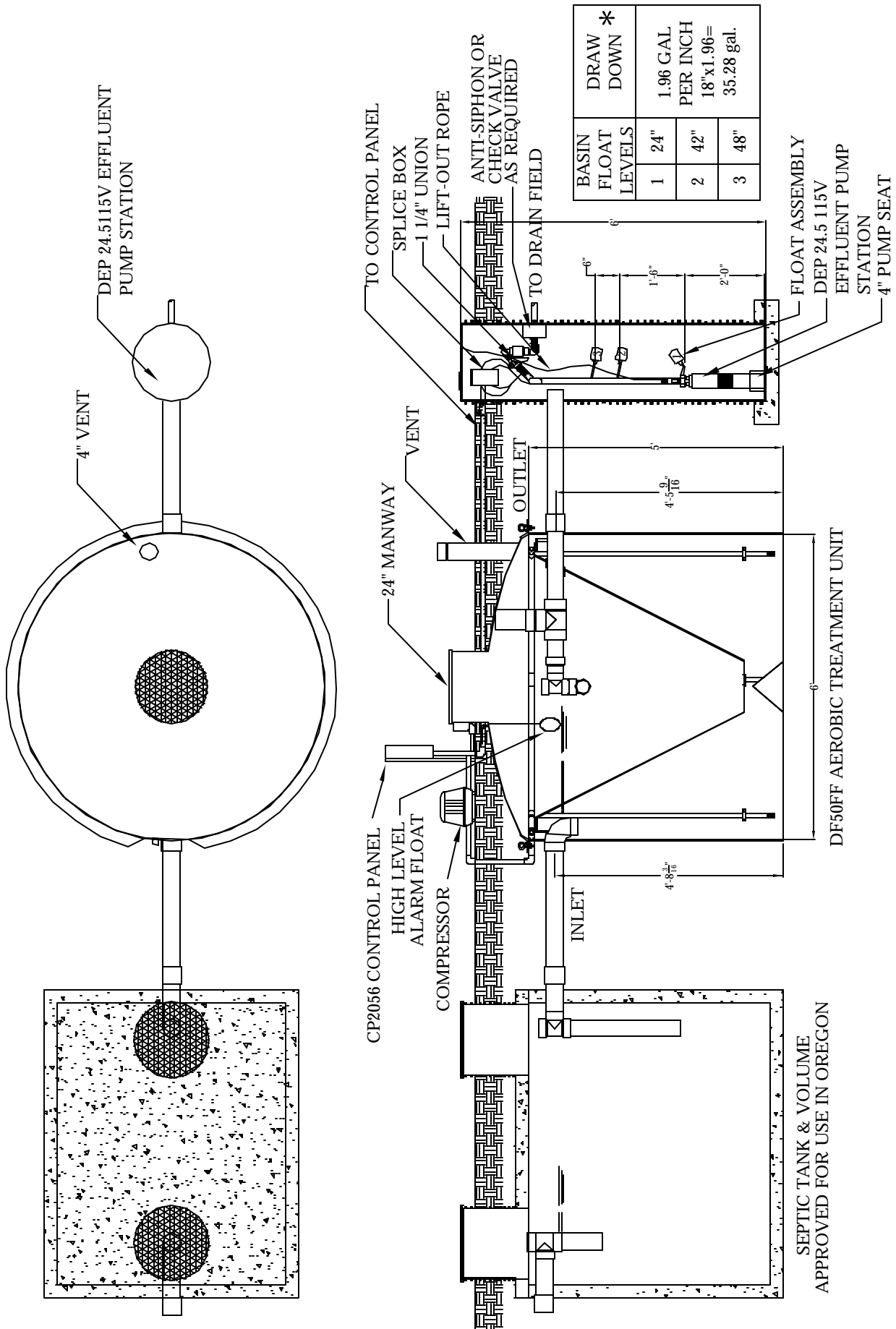

SEPTIC TANK & VOLUME
APPROVED FOR USE IN OREGON

*NOTE: ALL EXTERIOR PIPE SIZE AS PER OREGON REQUIREMENTS
*NOTE: THE VOLUME OF THE SEPTIC TANK WILL BE AS REQUIRED IN OAR 340-071



DELTA ENVIRONMENTAL PRODUCTS, INC.
P. O. BOX 969 DENHAM SPRINGS, LA 70727

DELTA WHITEWATER 500GPD UNIT W/ OREGON APPROVED SEPTIC TANK & DEP24.5115V HIGH HEAD PUMP STATION

DWN BY: C.RACHAL
DATE: 4/16/07
SCALE: N.T.S.
DWG. NO.: DEP248A-DF50

CONFIGURATION 1

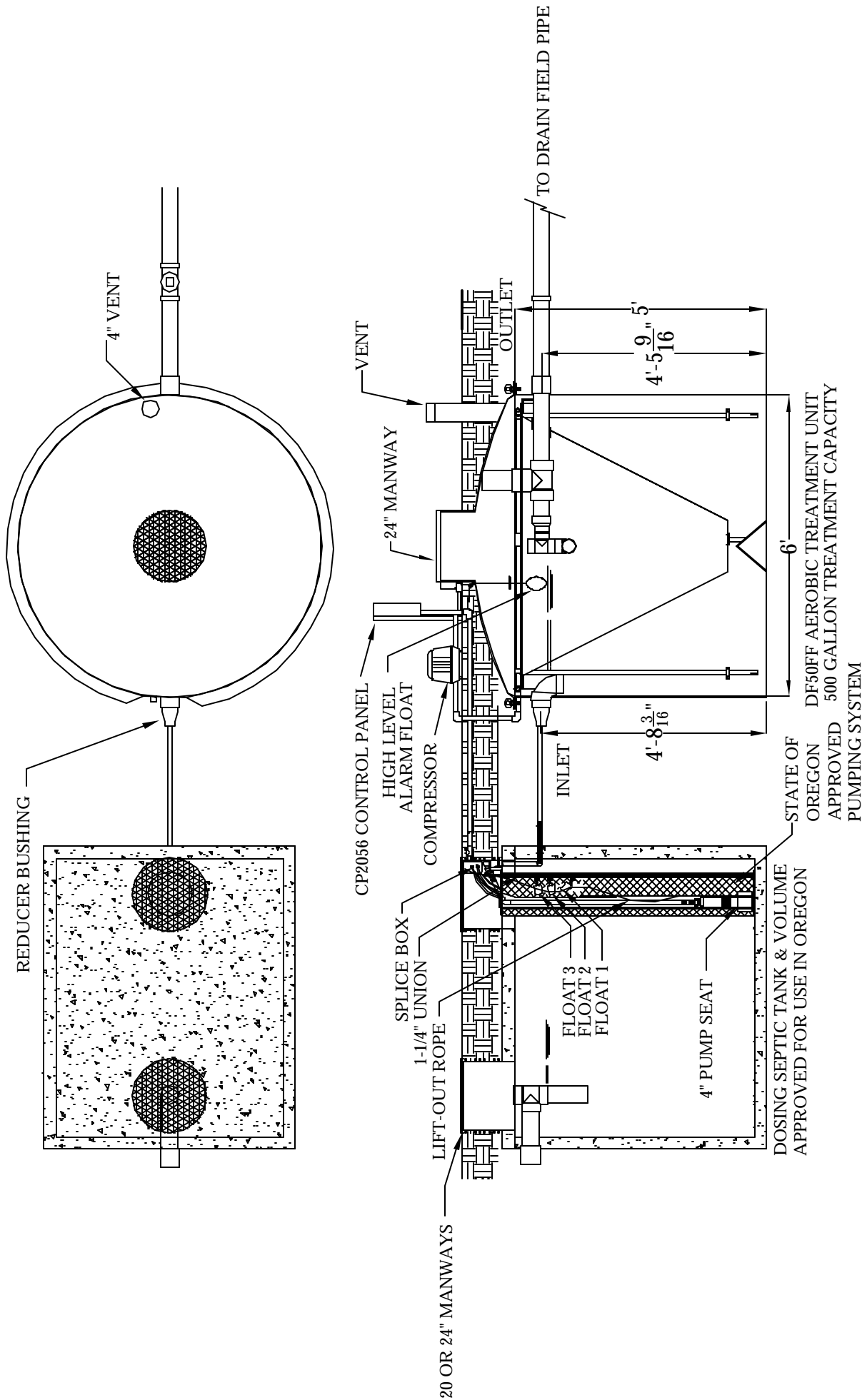

*NOTE: THE VOLUME OF THE SEPTIC TANK WILL BE AS REQUIRED IN OAR 340-071
 *NOTE: ALL EXTERIOR PIPE SIZE AS PER OREGON REQUIREMENTS

	DELTA WHITEWATER 500GPD UNIT W/ OREGON APPROVED DOSING SEPTIC TANK		
	DWN BY: C.RACHAL	DATE: 4/16/07	SCALE: N.T.S.

CONFIGURATION 2

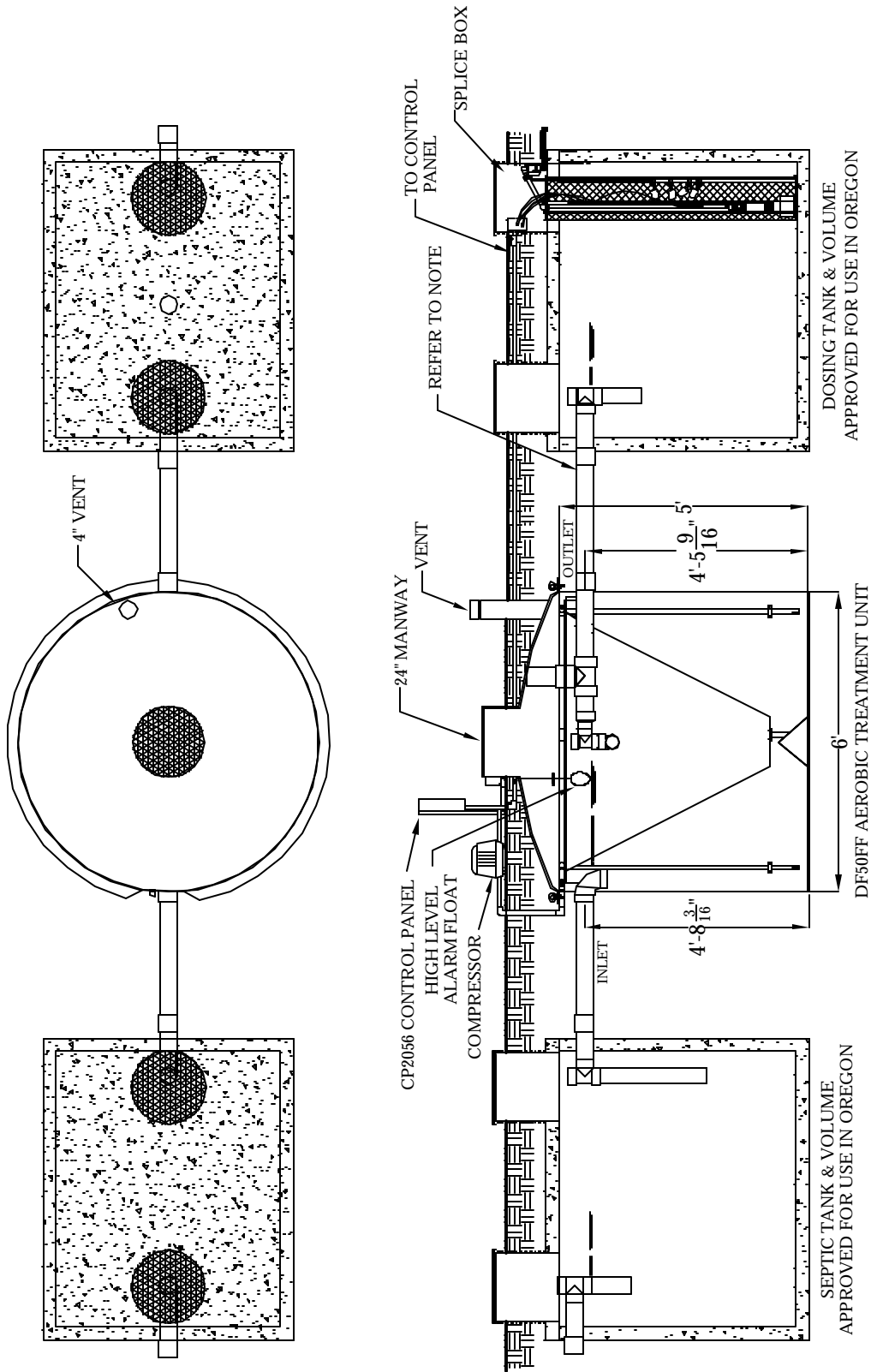

*NOTE: ALL EXTERIOR PIPE SIZE AS PER OREGON REQUIREMENTS

*NOTE: THE VOLUME OF THE DOSING TANK WILL BE AS REQUIRED IN OAR 340-071

*NOTE: THE VOLUME OF THE SEPTIC TANK WILL BE AS REQUIRED IN OAR 340-071



DELTA ENVIRONMENTAL PRODUCTS, INC.
P. O. BOX 969 DENHAM SPRINGS, LA 70727

DELTA WHITEWATER 500GPD UNIT W/ OREGON
APPROVED SEPTIC TANK & DOSING TANK

DWN BY:
C. RACHAL

DATE:
4/16/07

SCALE:
N.T.S.

DWG. NO.:
DEP248C-DF50

CONFIGURATION 3

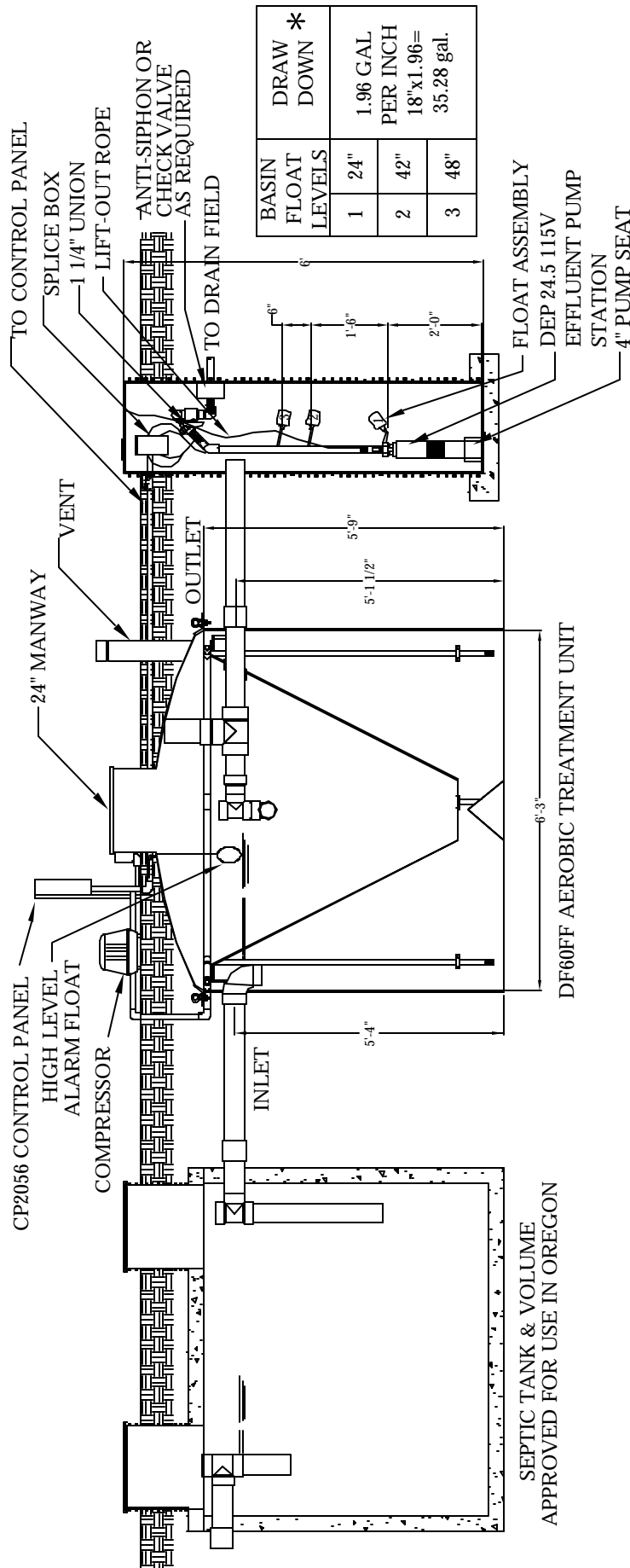
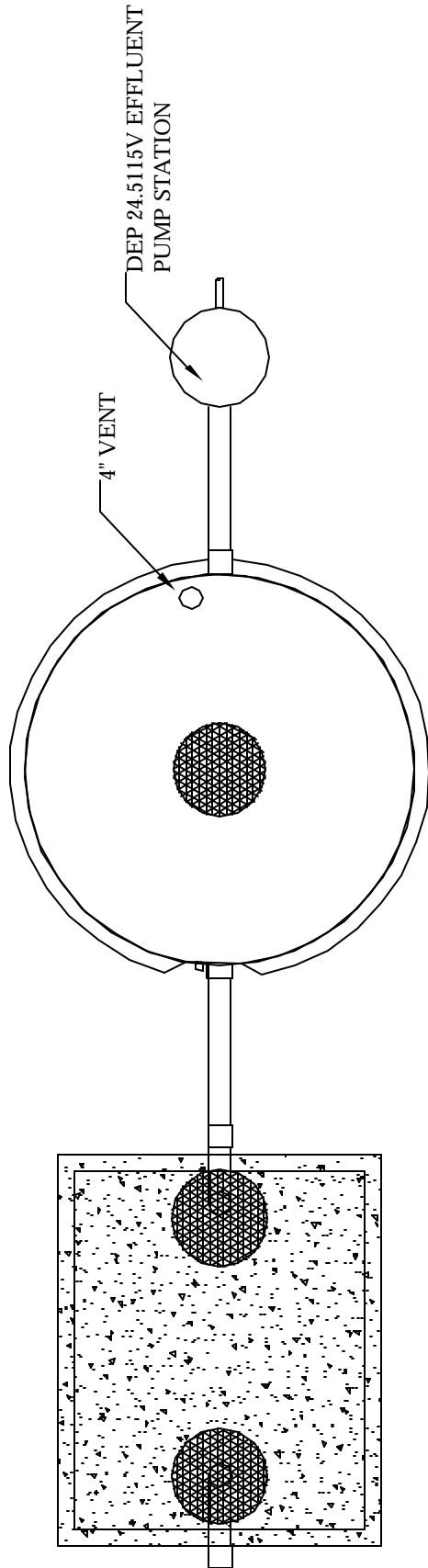

BASIN FLOAT LEVELS	DRAW DOWN *
1 24"	1.96 GAL PER INCH
2 42"	18"x1.96=
3 48"	35.28 gal.

SEPTIC TANK & VOLUME
APPROVED FOR USE IN OREGON

*NOTE: ALL EXTERIOR PIPE SIZE AS PER OREGON REQUIREMENTS
*NOTE: THE VOLUME OF THE SEPTIC TANK WILL BE AS REQUIRED IN OAR 340-071-220(3)



DELTA ENVIRONMENTAL PRODUCTS, INC.
P. O. BOX 969 DENHAM SPRINGS, LA 70727

DELTA WHITEWATER 600GPD UNIT W/ OREGON APPROVED SEPTIC TANK & DEP24.5115V HIGH HEAD PUMP STATION

DWG. NO.: DEP248A-DF60

DWN BY: C.RACHAL

DATE: 4/16/07

SCALE: N.T.S.

DWG. NO.: DEP248A-DF60

CONFIGURATION 1

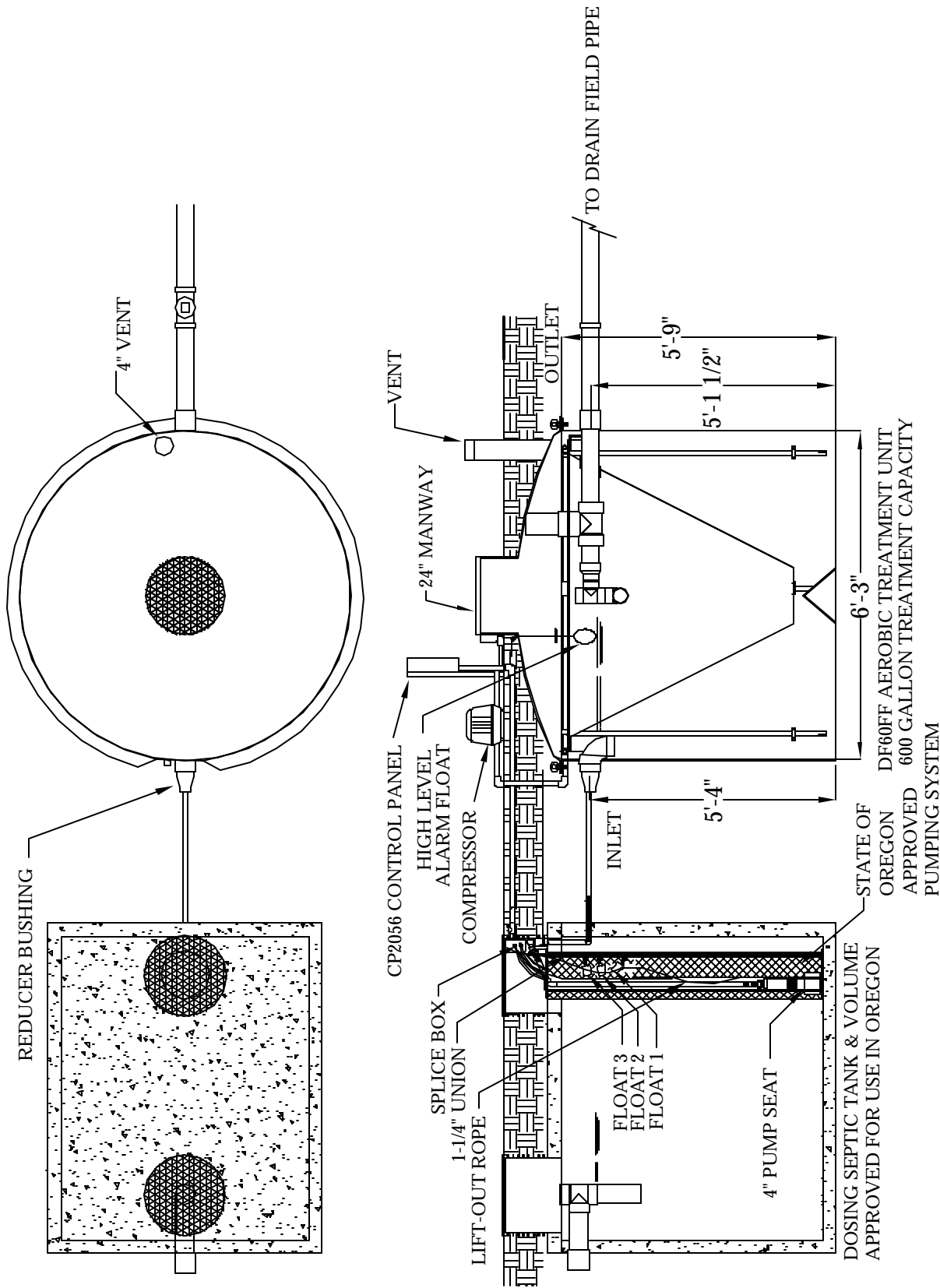

*NOTE: THE VOLUME OF THE SEPTIC TANK WILL BE AS REQUIRED IN OAR 340-071
 *NOTE: ALL EXTERIOR PIPE SIZE AS PER OREGON REQUIREMENTS

		DELTA WHITEWATER 600GPD UNIT W/ OREGON APPROVED DOSING SEPTIC TANK	
CONFIGURATION 2	DWN BY: C.RACHAL	DATE: 4/16/07	SCALE: N.T.S.
		DWG. NO.: DEP248B-DF60	

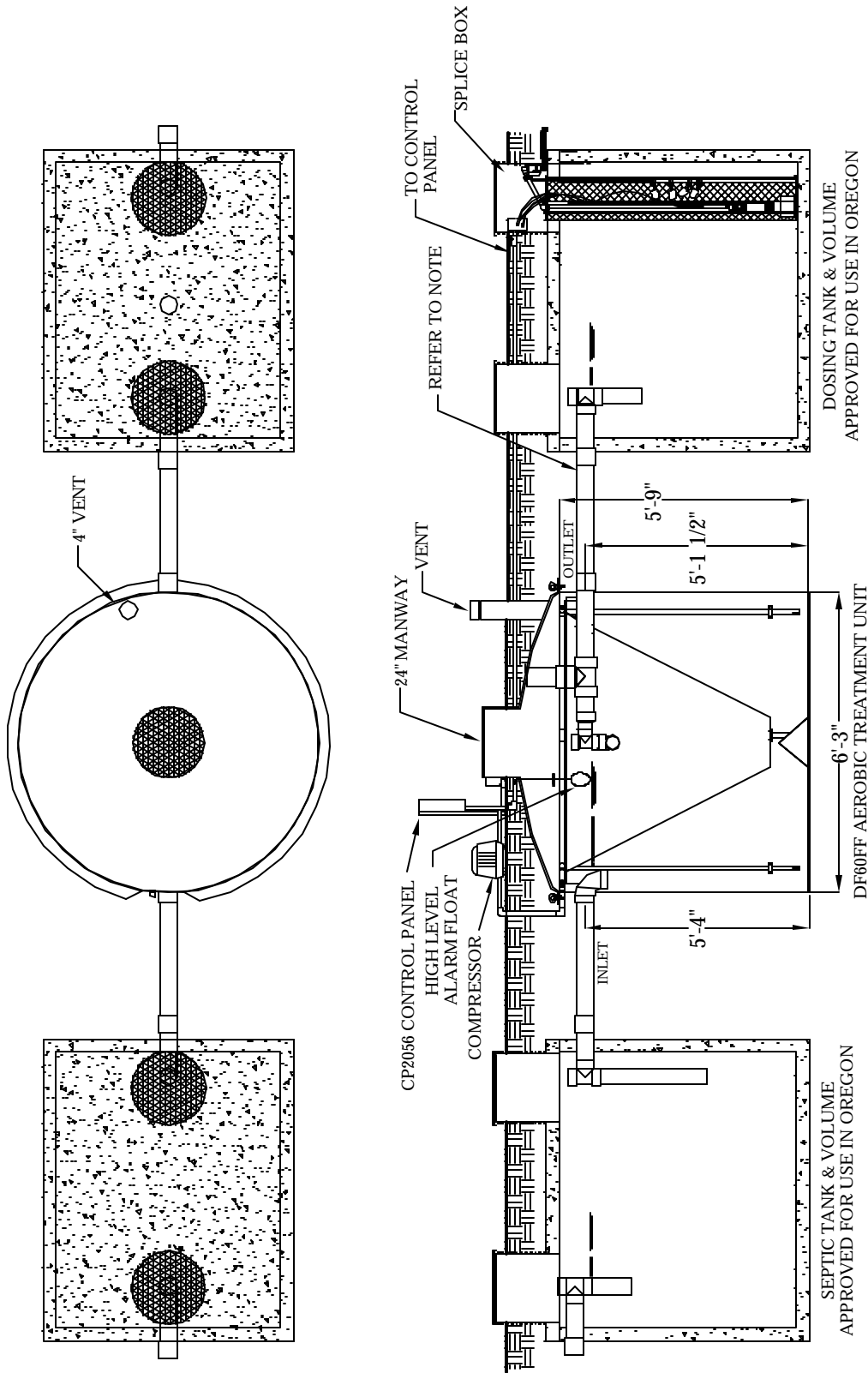

*NOTE: ALL EXTERIOR PIPE SIZE AS PER OREGON REQUIREMENTS
 *NOTE: THE VOLUME OF THE DOSING TANK WILL BE AS REQUIRED IN OAR 340-071
 *NOTE: THE VOLUME OF THE SEPTIC TANK WILL BE AS REQUIRED IN OAR 340-071



DELTA ENVIRONMENTAL PRODUCTS, INC.
 P. O. BOX 969 DENHAM SPRINGS, LA 70727

DELTA WHITEWATER 600GPD UNIT W/ OREGON
 APPROVED SEPTIC TANK & DOSING TANK

DWN BY:
 C. RACHAL

DATE:
 4/16/07

SCALE:
 N.T.S.

DWG. NO.:
 DEP248C-DF60

CONFIGURATION 3

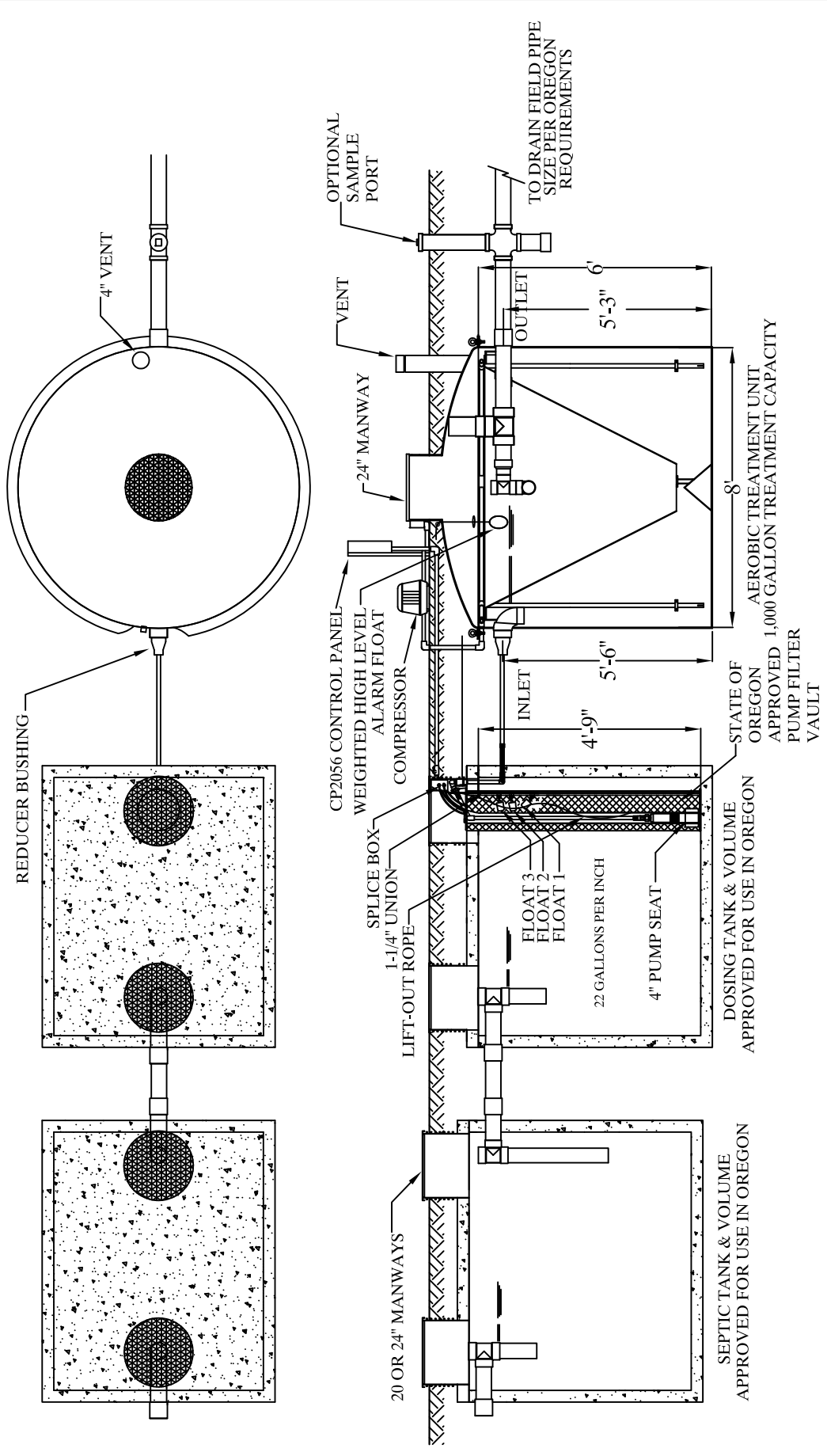

*NOTE: THE VOLUME OF THE SEPTIC TANK WILL BE AS REQUIRED ON OAR 340-071-220 (3)
 *NOTE: ALL EXTERIOR PIPE SIZE AS PER OREGON REQUIREMENTS



DELTA ENVIRONMENTAL PRODUCTS, INC.
 P. O. BOX 969 DENHAM SPRINGS, LA. 70727

DELTA WHITEWATER 1,000GPD UNIT W/ OREGON APPROVED SEPTIC TANK/DEP.5115 HIGH HEAD SCREEN PUMP VAULT

DWG. NO.: DEP248E
 SCALE: N.T.S.
 DATE: 11/16/06
 DWN BY: B.LANDRY

CONFIGURATION 2

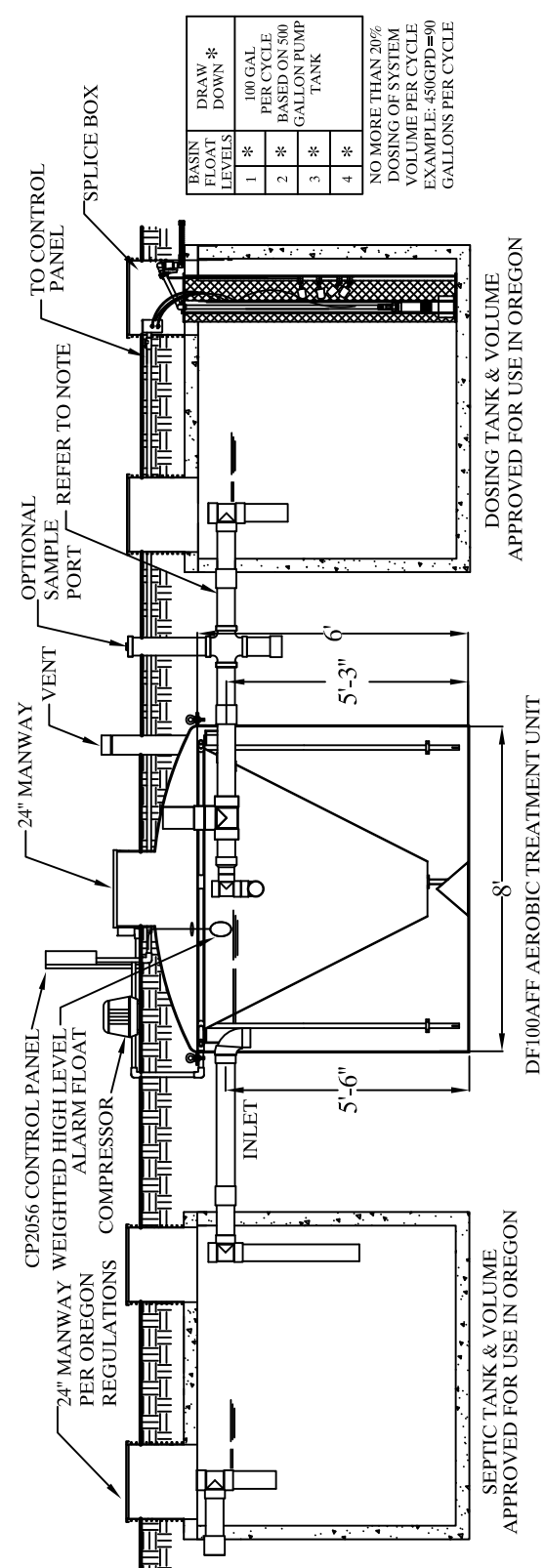
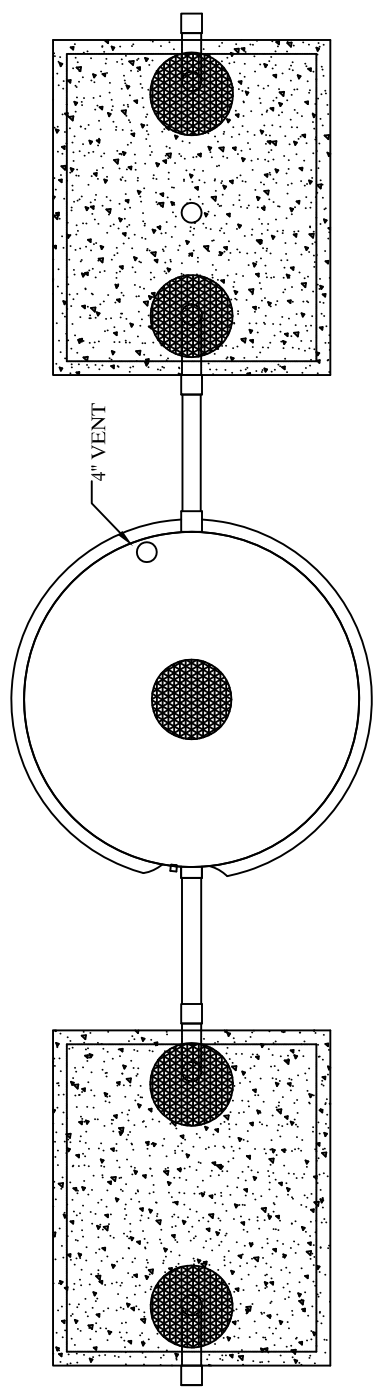

BASIN FLOAT LEVELS	DRAW DOWN *
1 *	100 GAL PER CYCLE
2 *	BASED ON 500 GALLON PUMP TANK
3 *	
4 *	

NO MORE THAN 20% DOSING OF SYSTEM VOLUME PER CYCLE
EXAMPLE: 450GPD=90 GALLONS PER CYCLE

PUMP CHART			
PUMP	ELEVATION	MAX. DISTANCE	MIN. PIPE SIZE
1/2 HP	30'	500'	min. 3"
1 HP	100'	1000'	min. 3"

*NOTE: ALL EXTERIOR PIPE SIZE AS PER OREGON REQUIREMENTS
 *NOTE: THE VOLUME OF THE DOSING TANK WILL BE AS REQUIRED IN OAR 340-071-220(6)
 *NOTE: THE VOLUME OF THE SEPTIC TANK WILL BE AS REQUIRED IN OAR 340-071-220(3)

CONFIGURATION 3

 DELTA ENVIRONMENTAL PRODUCTS, INC.
 P. O. BOX 969 DENHAM SPRINGS, LA. 70727

DELTA WHITEWATER 1,000GPD UNIT W/ OREGON
 APPROVED SEPTIC TANK & DOSING TANK

DWN BY: B. LANDRY
 DATE: 05/09/05
 SCALE: N.T.S.
 DWG. NO.: DEP248F

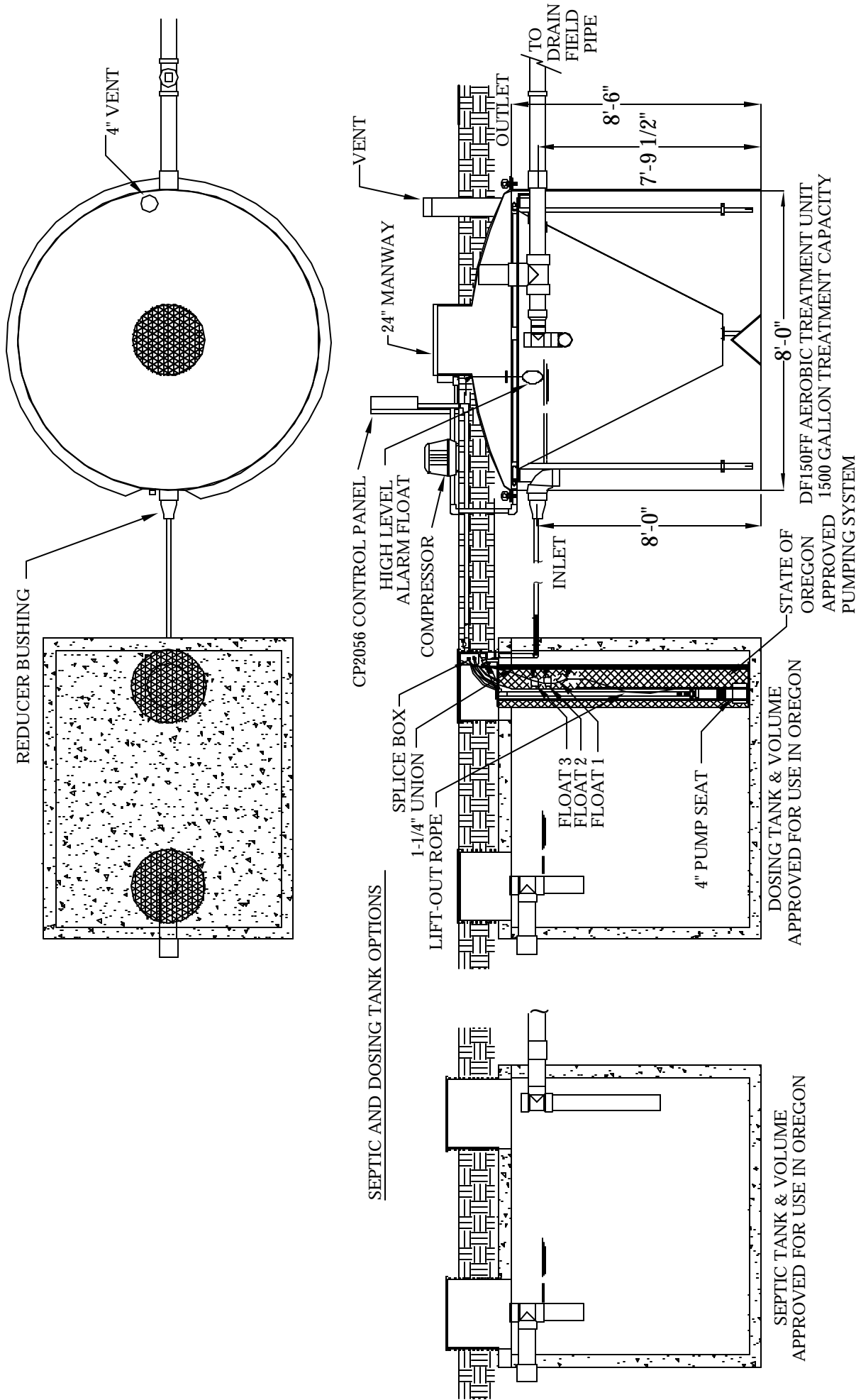

*NOTE: THE VOLUME OF THE SEPTIC TANK WILL BE AS REQUIRED IN OAR 340-071
 *NOTE: ALL EXTERIOR PIPE SIZE AS PER OREGON REQUIREMENTS

	DELTA WHITEWATER 1500GPD UNIT W/ OREGON APPROVED PRECEDING SEPTIC & DOSING TANKS		SCALE: N.T.S.	DWG. NO.: DEP248B-DF150
	DWN BY: C.RACHAL	DATE: 4/16/07		

CONFIGURATION 2

DELTA ENVIRONMENTAL PRODUCTS, INC.
 P. O. BOX 969 DENHAM SPRINGS, LA 70727

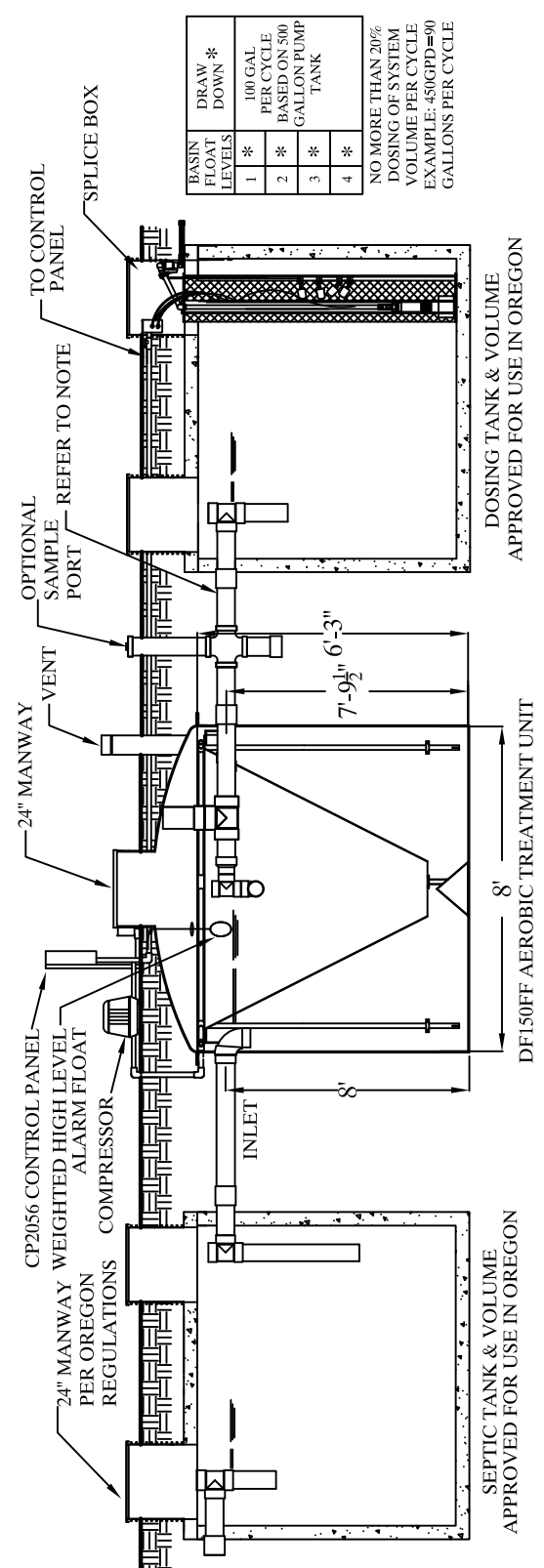
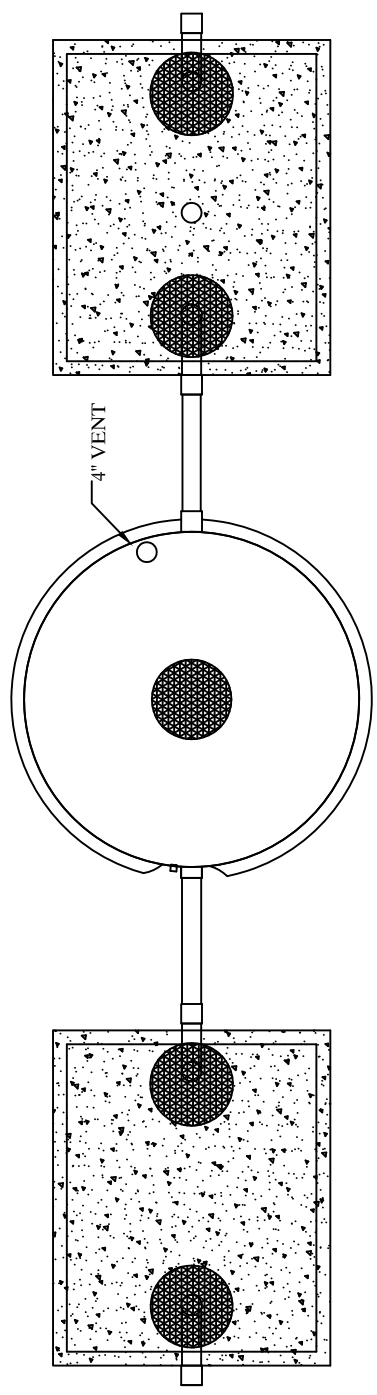

BASIN FLOAT LEVELS	DRAW DOWN *
1 *	100 GAL PER CYCLE
2 *	BASED ON 500 GALLON PUMP TANK
3 *	
4 *	

NO MORE THAN 20% DOSING OF SYSTEM VOLUME PER CYCLE
EXAMPLE: 450GPD=90 GALLONS PER CYCLE

PUMP CHART			
PUMP	ELEVATION	MAX. DISTANCE	MIN. PIPE SIZE
1/2 HP	30'	500'	min. 3"
1 HP	100'	1000'	min. 3"

*NOTE: ALL EXTERIOR PIPE SIZE AS PER OREGON REQUIREMENTS
 *NOTE: THE VOLUME OF THE DOSING TANK WILL BE AS REQUIRED IN OAR 340-071-220(6)
 *NOTE: THE VOLUME OF THE SEPTIC TANK WILL BE AS REQUIRED IN OAR 340-071-220(3)

CONFIGURATION 3



 DELTA ENVIRONMENTAL PRODUCTS, INC.
 P. O. BOX 969 DENHAM SPRINGS, LA. 70727

DELTA WHITEWATER 1500GPD UNIT W/ OREGON
 APPROVED SEPTIC TANK & DOSING TANK

DWN BY: B. LANDRY
 DATE: 05/09/05
 SCALE: N.T.S.
 DWG. NO.: DEP248C

INSTALLATION

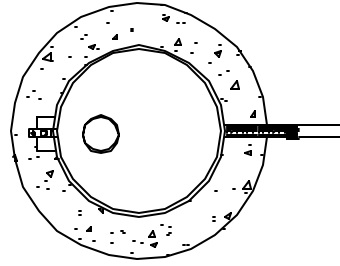
1. The basin is plastic pipe with sealed fiberglass bottom and optional anti-floatation ring to prevent basin from floating up in high water conditions. Do not leave basin in unfilled hole without concrete as ground water or rain may float basin up breaking inlet, discharge and electrical conduit connections.
2. A 3' dia. x 4" thk. concrete base is required for anchoring purposes.



ELECTRICAL ASSEMBLY

1. Connect level control and pump power cords to junction box as shown in diagram. Make certain all compression fittings are tight.
2. Install control panel.
3. Run wires to control panel through conduit and connect cords coming into connection box. Mark or trace each incoming wire so that it can be connected to the proper cord.

STARTING SYSTEM

1. Open ball valve.
2. Run water into basin until the "ON" level control starts the pump. Allow pump to operate until sump level drops, deactivating "OFF" level control, stopping pump.

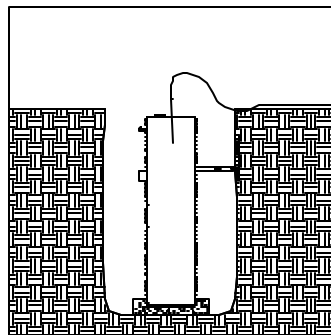
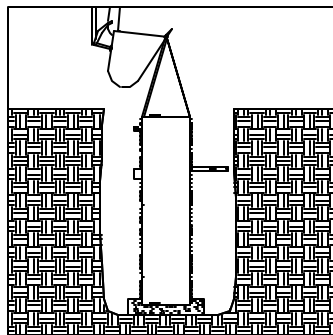
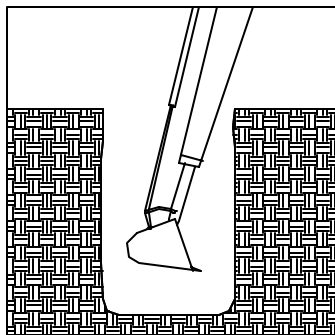
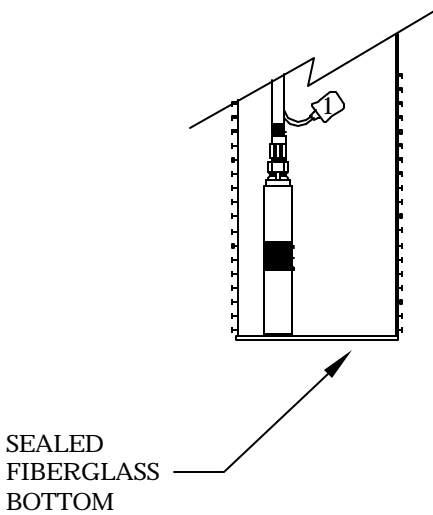
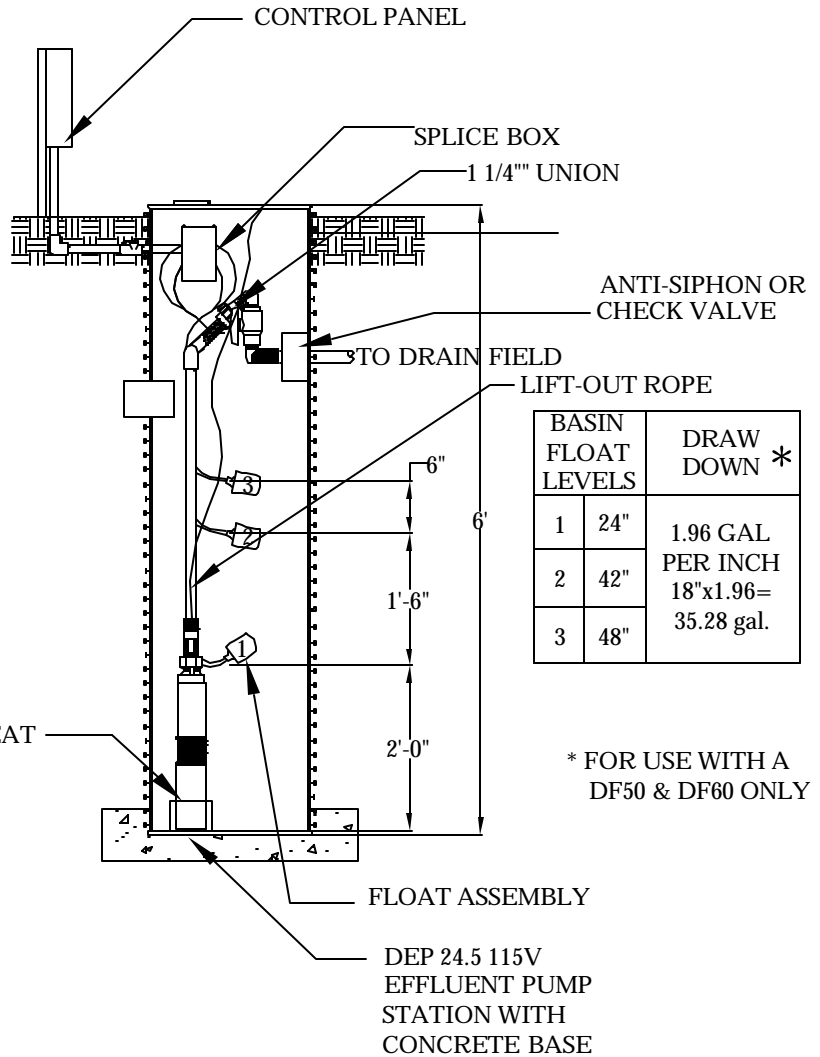

DELTA ENVIRONMENTAL PRODUCTS, INC.
P. O. BOX 969 DENHAM SPRINGS, LA 70727

PUMP VAULT INSTALLATION PROCEDURES

DWN BY:
C.RACHAL

DATE:
4/16/07

SCALE:
N.T.S.

DWG. NO.:
DEP287-DF50/DF60

TROUBLE SHOOTING GUIDE FOR DELTA WHITEWATER AEROBIC TREATMENT UNITS

AIR SUPPLY MALFUNCTION

1. Check to be sure all airdrops are working properly. They should be bubbling evenly and forcefully. A septic (rotten egg) odor could mean that the system is not getting enough air. If the air drops are not working, partially working or working very little (slight bubbles), check the following:
 - a. Check to be sure the air pump is working.
 - check timer if one is used
 - bypass timer/temporarily connect directly to source
 - check the electrical source
 - if electrical source is ok-check service guide for pump unit troubleshooting information
 - wash air filter on pump
 - consult manufacturer for servicing information
 - b. Check to be sure tank is not severely out of level. Air follows a path of least resistance. The pressure differences at the bottom of drop lines can be enough to prevent or restrict air flow.
 - c. Check for broken or cracked air lines both outside and inside the tank.
 - d. Ants will destroy an air pump. Check to see if there is an ant nest around the air pump.
 - e. Air pump should be protected from rising water.
 - f. Always check to see if inlet and outlet lines are correctly installed.

INTERNAL ASSEMBLY MALFUNCTION

1. Raw, untreated sewage from the aeration chamber (bubble zone) should not enter the clarifier (quiet zone) because of improperly installed or loose seals or gaskets where pipe goes through the clarifier wall. Check the size of holes to be sure that there is no clearance for matter to pass through the wall around the piping.
2. Check to be sure all internal piping and connections are tight.

DESIGN OVERLOAD

1. The system could be hydraulically overloaded (there is too much water going through the system for the size of the system).
2. The system could be biologically overloaded (there is too much waste for the size of the system).

IMPROPER INSTALLATION OR SETTLING

1. You should follow the manufacturer's installation procedures very carefully.
2. Where settling is common, approximately 6" of sand should be placed and tamped in the bottom of the hole.
3. Proper installation is the first step in preventing call backs for service problems.
4. Whenever possible, it is important to spend time with the homeowner. Be sure they have an operations book. A few minutes invested in the beginning will avoid service calls later.

NO HARSH CHEMICALS SHOULD BE PUT INTO THE SYSTEM

1. Water in the aeration chamber (bubble zone) should be the color of chocolate milk. Blue or gray/blue water indicates heavy use of detergents or other chemicals. If water appears sudsy there is too much detergent being used.

TROUBLE SHOOTING ELECTRICAL SYSTEM

1. Air pump does not run:
 - a. Check main service for power.
 - b. Check and/or replace fuse with same rating as is in control panel.

2. Alarm does not occur when air pump is off:
 - a. Malfunctioning pressure switch - replace.
 - b. Malfunctioning light or buzzer - replace.

3. Alarm occurs continuously even when air pump is running
 - a. Air leak in main air system or air tubing to pressure switch - repair leak or replace air line.
 - b. Malfunctioning pressure switch - replace.
 - c. High water level in tank - inspect for cause.
 - d. Short in float switch wire or float switches - repair or replace.

NOTE: All replacement parts are available from your local dealer.

CAUTION: Electrical shock or hazard may occur if unit is not serviced properly. The manufacturer recommends that a licensed electrician be called when electrical problems occur.

COMPONENT REPLACEMENT PROCEDURE

1. **Air Pump**: Follow the same procedure as outlined in the “Installation Instructions.”
2. **Float Switch**: Remove Aerobic Treatment Plant’s Riser or 24” cover. Locate float switch cable. Untie knot. Cut float switch cable. Slip float switch cable through rubber grommet into the plant. Replace with exact replacement float switch. Reinstall by reversing the procedure. Reconnect float switch wires using underground rated compound filled wire nuts. **See Float Switch Mounting Details.**
3. **Pressure Switch**: Turn all power off to the control panel. Remove back plate. Remove screws securing pressure switch as well as connectors and tubing. Reverse procedure to install new pressure switch.
4. **Buzzer**: Turn all power off to the control panel. Remove screw attaching buzzer to back plate as well as connectors. Reverse procedure to install new buzzer.
5. **Lamp holder**: Turn all power off to control power. Remove lock nut securing lamp holder to door as well as connectors. Remove lamp holder. Install new lamp holder with gaskets furnished. Continue with reverse procedure.
6. **Lamp**: Turn all power off to control panel. Remove red lamp cover from front of control panel. Remove and replace lamp which is a push in type. Replace lamp cover and cover gasket.
7. **Fuse**: Turn all power off to control panel. Pull top of fuse holder outward. Remove and replace fuse. Push fuse back into place.
8. **Buzzer Switch**: Turn all power off to control panel. Remove rubber boot on switch. Remove hex nut from switch on panel front as well as connectors on switch. Reverse procedure to install new switch.

GENERAL COMMENTS

1. Only factory approved equipment can be used for replacement on individual treatment systems.
2. If the decision is made to pump out a system, be sure to contact a licensed waste-hauler.
3. If a chronic problem develops and all items have been checked, consult with the factory.
4. Keep good records.

NOTE:

If the entire cover needs to be removed on any one of the various model treatment plants, the existing silicone or strip seal must be removed and replaced with a new one. This will provide a positive seal which will not allow any infiltration into or out of the treatment plant.

**APPENDIX A
SPECIFICATIONS, DIMENSIONS AND
TREATMENT PLANT DRAWINGS**

SPECIFICATIONS

TREATMENT PLANT	TREATMENT CAPACITY (GPD)	TOTAL VOLUME (GAL)	AERATION VOLUME (GAL)	CLARIFIER VOLUME (GAL)	BOD LOADING (LBS/DAY)	NO. OF AIR DROPS
DF50	500	909	720	189	1.25	5
DF60	600	1147	867	280	1.5	6
DF100A	1000	1926	1429	497	2.5	8
DF150	1500	2882	2227	655	3.75	8

MATERIALS OF CONSTRUCTION:

Suffix FF*	Aeration Tank	Fiberglass
	Cover	Fiberglass
	Clarifier	Fiberglass
	Piping	PVC

***Standard Production Units. Other configurations are available upon special request.**

**PARTS LIST:
CONSTRUCTION**

ITEM MATERIALS OF

Aeration Tank	1.	See Above
Clarifier	2.	See Above
Air Distribution System	3.	PVC
Access Cover	4.	Polyethylene
Discharge Piping Assembly	5.	PVC
Air Pump Assembly	6.	See Air Pump Parts List
Sample Port	7.	PVC
Control Panel	8.	NEMA 3R Steel or NEMA 4X Fiberglass
High Water Float Switch	9.	Polyethylene

Electrical Requirements

<u>Model</u>	<u>Compressor</u>	<u>Motor full load Amps</u>	<u>Measured Operating Watts</u>	<u>Electrical Requirements</u>
DF50	5060A/5080S/5078S/0323/ QR-0030/EL-80-17 Delta Model 60 Delta Model 80	1.75/2.1/ 2.1/4.0/ 5.6/1.8 1.75/2.1	63/85/85/391/ 300/131/63/85 Watts	115 volt - single phase
DF60	5080A/0523/5100S/QR-50/ EL-80-17 Delta Model 80 Delta Model 100	2.1/4.6/ 2.71/5.3/ 1.8 2.1/2.71	85/449/110/ 518/131/85/ 110 Watts	115 volt - single phase
DF100A	(2)5080S/ (1)QR-0080/ (2)EL-80-17 (2)Delta Model 80	(2)2.1 (1)10.4 (2)1.8 (2)2.1	(2)85 Watts (1)640 Watts (2)131 Watts (2)85 Watts	115 volt - single phase
DF150	(3)5100s/ (1)QR-0100/ (2)5120s (3)Delta Model 100 (2)Delta Model 120	(3)2.71 (1)10.4 (2)2.8 (3)2.71 (2)2.8	(3)110 Watts (1)850 Watts (2)157 Watts (3)110 Watts (2)157 Watts	115 volt - single phase

DIMENSIONS

<u>Treatment Plant</u>	A	B	C	D	E	F
DF50	4'-11 3/16"	4'-8 3/16"	6'-0"	4'-5 9/16"	5'-0"	10"
DF60	5'-7 3/4"	5'-4"	6'-3"	5'-1 1/2"	5'-9"	11 1/2"
DF100A	5'-9 5/8"	5'-6"	8'-0"	5'-3"	6'-0"	1'-0"
DF150	8'-3 5/8"	8'-0"	8'-0"	7'-9 1/2"	8'-6"	1'-3 3/4"

REFER TO TREATMENT PLANT DRAWINGS ON THE ABOVE DIMENSIONS.

NOTE: For special cargo or container shipments 12 inches must be added to the diameters of all fiberglass units (due to the fiberglass flange and lifting lugs).

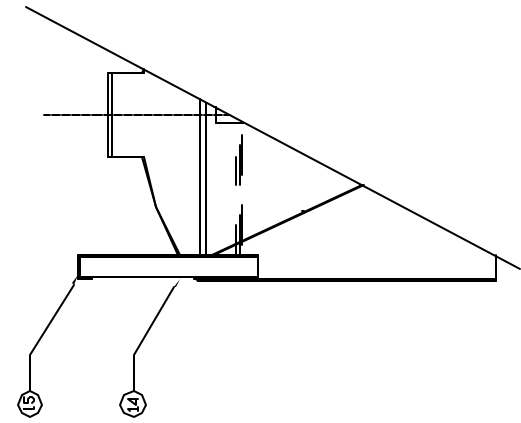

SECTION B-B

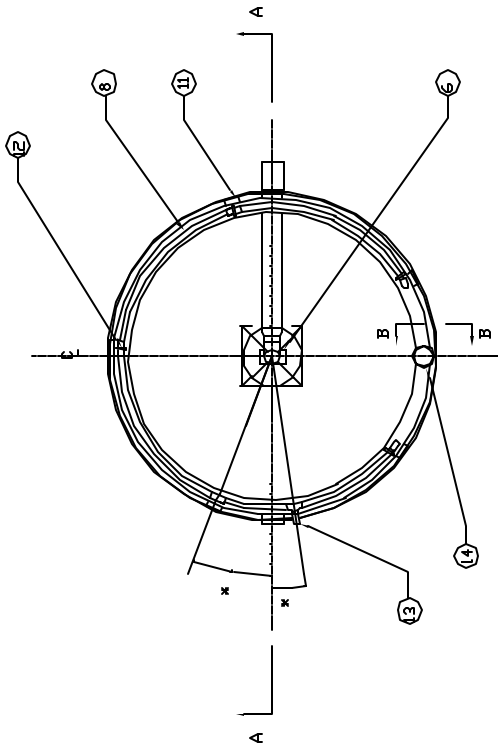

PLAN VIEW
(COVER NOT SHOWN THIS VIEW)

M14 SEALING TENS SOREVS
(A10 STAINLESS STEEL)

SILICONE SEAL

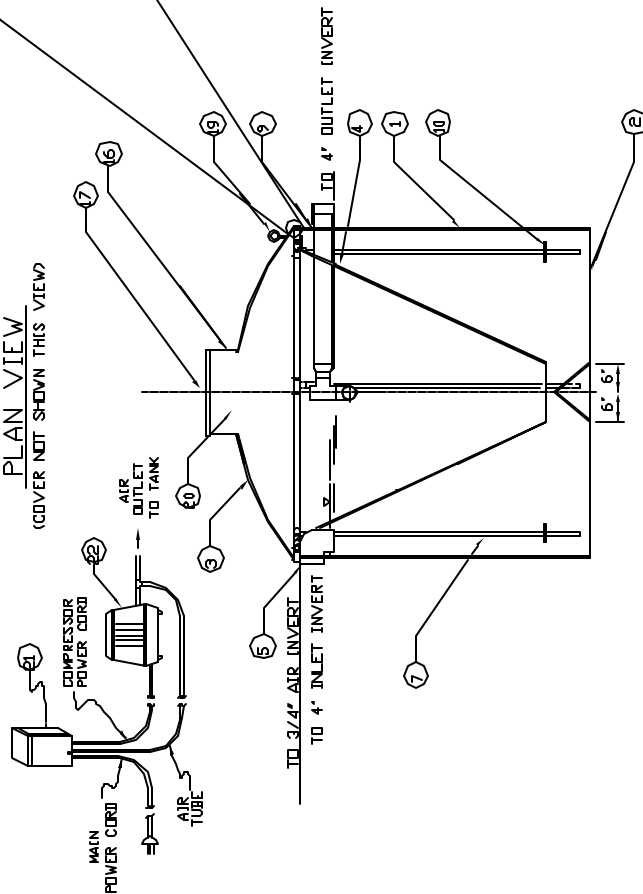

SECTION A-A

- NOTES:
1. * - MEASURED ALONG OUTSIDE OF WALL COAL TAR COATING
 2. PAINT WITH 8 TO 10 MILS. MIN. OF COAL TAR COATING
 3. NOTCH CLARIFIER RIM AS REQUIRED TO CLEAR DROPLINE & AIR HEADER
 4. AIR DROPLINES ARE TO BE SPACED 72 DEGREES APART
 5. INSPECTION AND SAMPLE PORTS ARE TO BE LOCKED TO PREVENT UNAUTHORIZED ENTRY
 6. WELD THE DEFLECTOR TO THE FLOOR OF THE TREATMENT PLANT AND PAINT WITH 8 TO 10 MILS OF COAL TAR COATING

ITEM	DESCRIPTION	QTY.
22	COMPRESSOR	1
21	RAINFROOF CONTROL PANEL	1
20	TIE SEAL, 6" RUBBER	1
19	LIFTING LUG	2
18	PADLOCK	2
17	COVER, INSPECTION, 24" NON-SKID MANWAY	1
16	24" TANK OPENING	1
15	COVER, SAMPLE PORT, 4", SDR SCH 3034 PVC	1
14	PIPE, 4" X 3"-D, COEX CELLULAR CORE PVC, F-891	1
13	COUPLING, 3/4" NPT, STEEL	1
12	PLASTIC RETAINING STRAP	7
11	SUPPORT, CLARIFIER	5
10	TIE SEAL, 4" RUBBER	4
9	AIR HEADER, 3/4" SPA-FLEX PIPE	1
8	DROPLINE, 3/4" SCHEDULE 40 PVC	5
7	DISCHARGE ASSEMBLY, PVC & STYRENE	1
6	ELBOW, STREET, 90 DEGREE, 4", SDR SCH 3034 PVC	1
5	CLARIFIER, FIBERGLASS	1
4	ROOF, 17/8" X 57'-6 1/2" J.I., STD. FLANGED & DISHED, FIBERGLASS	1
3	SHEET, 12 GAUGE X 5'-8" DIAMETER, STEEL	1
2	SHEET, 14 GAUGE X 5'-0" X 17'-8" STEEL	1
1		



DELTA ENVIRONMENTAL PRODUCTS, INC.
P. O. BOX 969 DENHAM SPRINGS, LA 70727

MODEL DF BILL OF MATERIALS

DWN BY:
C. RACHAL

DATE:
4/16/07

SCALE:
N.T.S.

DWG. NO.:
DEP265

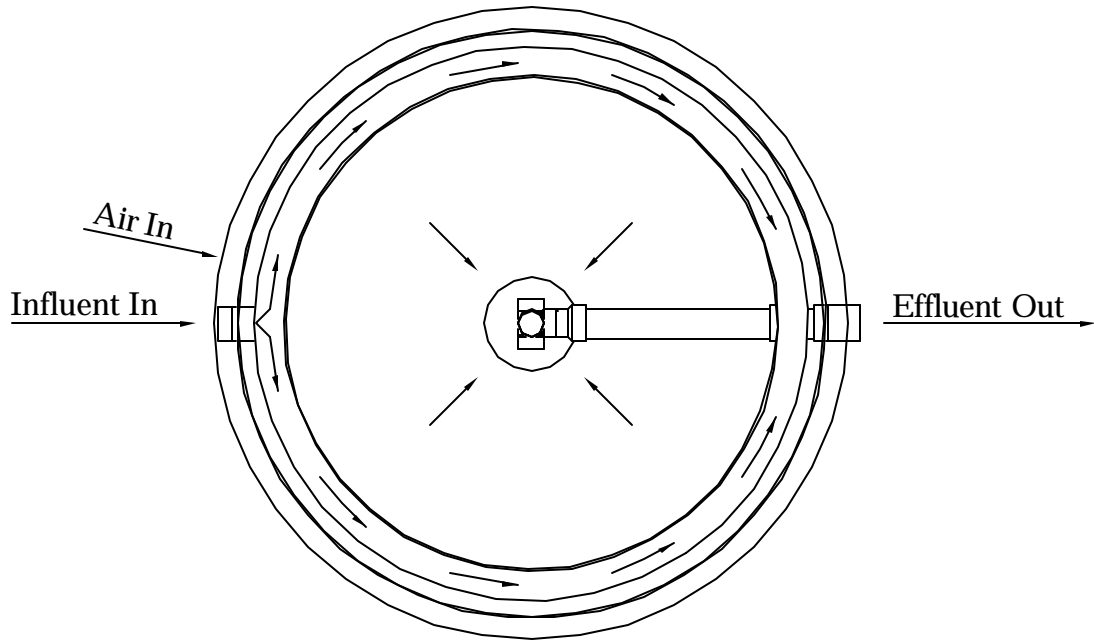

Plan View
(with cover removed)

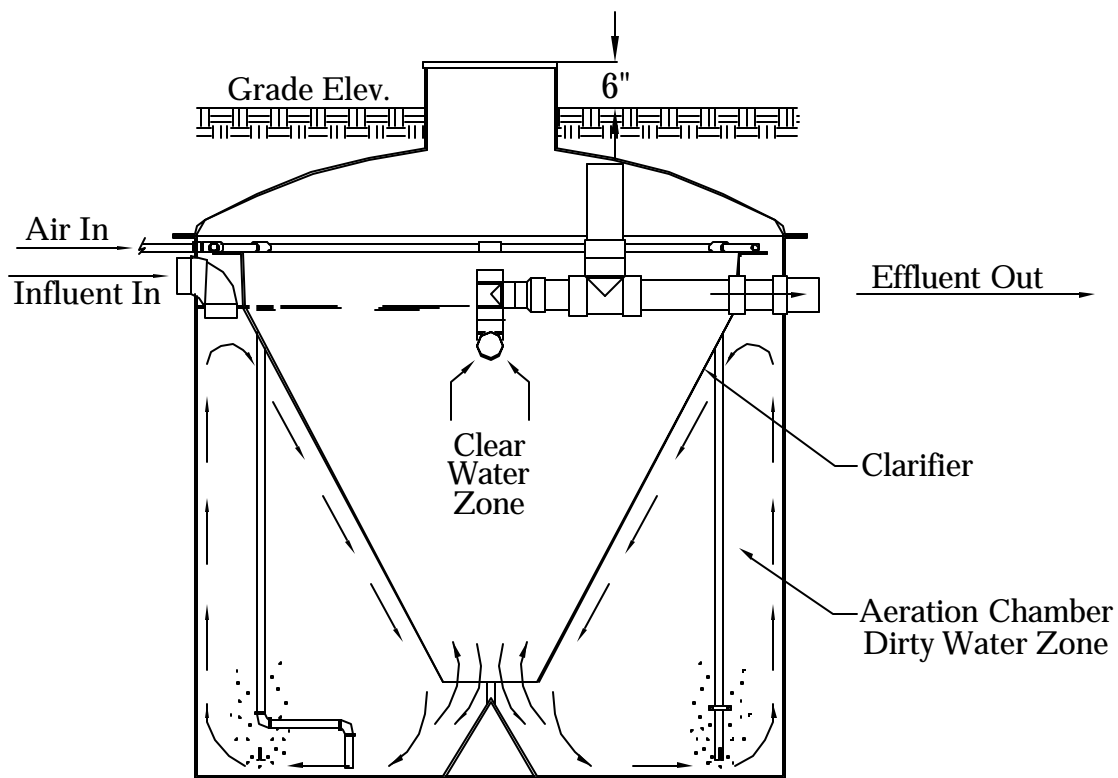

Section



Delta Environmental Products
P.O. Box 969 Denham Springs, LA 70727

**FLOW DIAGRAM
TREATMENT PLANTS**

DWN BY:
C.RACHAL

DATE:
4/16/07

SCALE:
N.T.S.

DWG. NO.:
CRT600

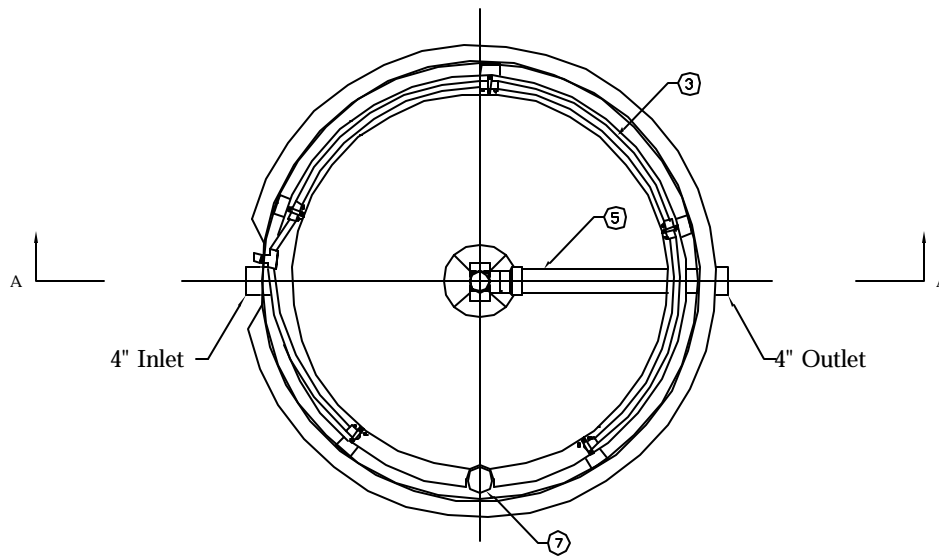

Plan View
(with cover removed)

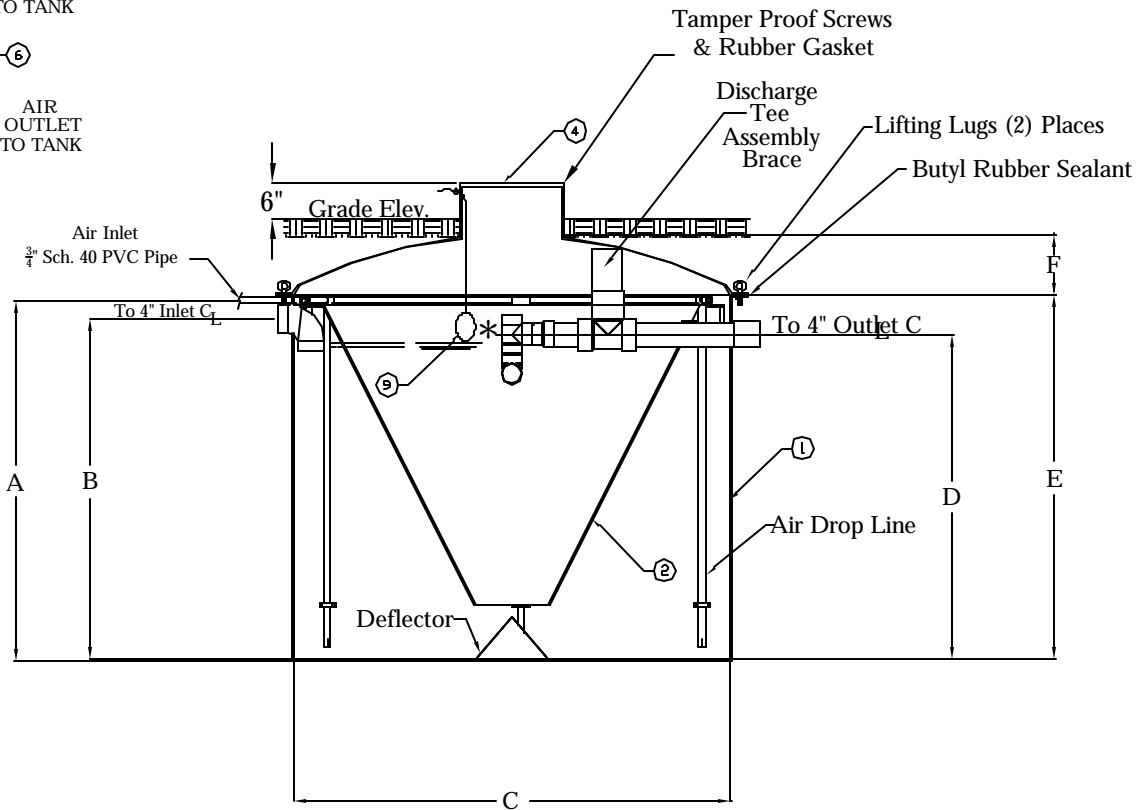
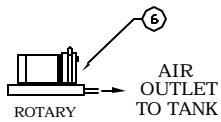
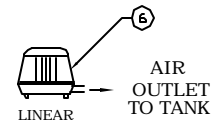
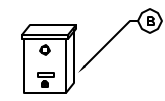

Section A-A

* HIGH LEVEL FLOAT NOT REQUIRED
WHEN USING CP22 SERIES CONTROL PANELS



Delta Environmental Products
P.O. Box 969 Denham Springs, LA 70727

WASTEWATER TREATMENT UNITS MODEL DFXX-FF

DWN BY:
C.RACHAL

DATE:
4/16/07

SCALE:
N.T.S.

DWG. NO.:
CRT603

**APPENDIX B
ELECTRICAL DRAWINGS**

COX

Research and Technology, Inc.

PUMP & COMPRESSOR
CONTROL PANEL

Cox Research and Technology, Inc.
14697 S. Harrells Ferry Road
Baton Rouge, LA. 70816
(225) 756-3271 Fax (225) 755-1030

CP-2056A

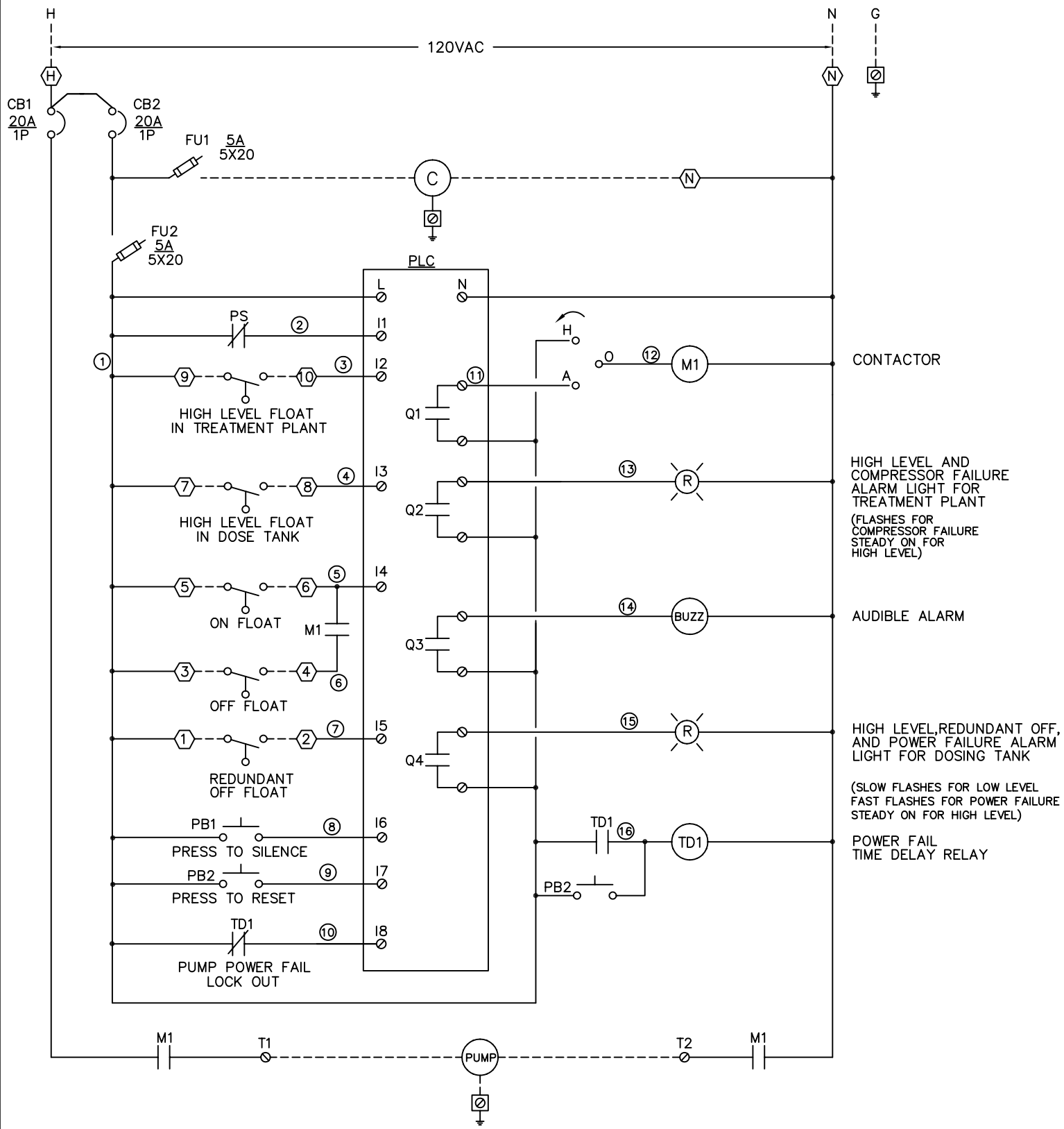

CONTACTOR

HIGH LEVEL AND COMPRESSOR FAILURE ALARM LIGHT FOR TREATMENT PLANT
(FLASHES FOR COMPRESSOR FAILURE STEADY ON FOR HIGH LEVEL)

AUDIBLE ALARM

HIGH LEVEL, REDUNDANT OFF, AND POWER FAILURE ALARM LIGHT FOR DOSING TANK
(SLOW FLASHES FOR LOW LEVEL FAST FLASHES FOR POWER FAILURE STEADY ON FOR HIGH LEVEL)

POWER FAIL TIME DELAY RELAY

PROGRAM: CP2056A

Drawing Title									
POWER/CONTROL DIAGRAM		REFERENCE DRAWING		NO.		REVISION-LOCATION		ECN	
		S/N		Sales Engineer		Application Engineer		DRAWN	
DATE		C.C.		R.C.		BY		APPROVED	
3/21/06						C. RACHAL			
Project Title		<p align="center">COX</p> <p align="center">Research and Technology, Inc.</p>		<p>P.O. Box 77808 Baton Rouge, LA 70809</p> <p>Ph. (225)756-3271 Fax (225)755-1030</p>		PURCHASE ORDER NUMBER			
PUMP & COMPRESSOR CONTROL PANEL						DRAWING NUMBER			
						CP-2056A			
						SHEET NUMBER			
						1			

NEMA 4X FIBERGLASS ENCLOSURE

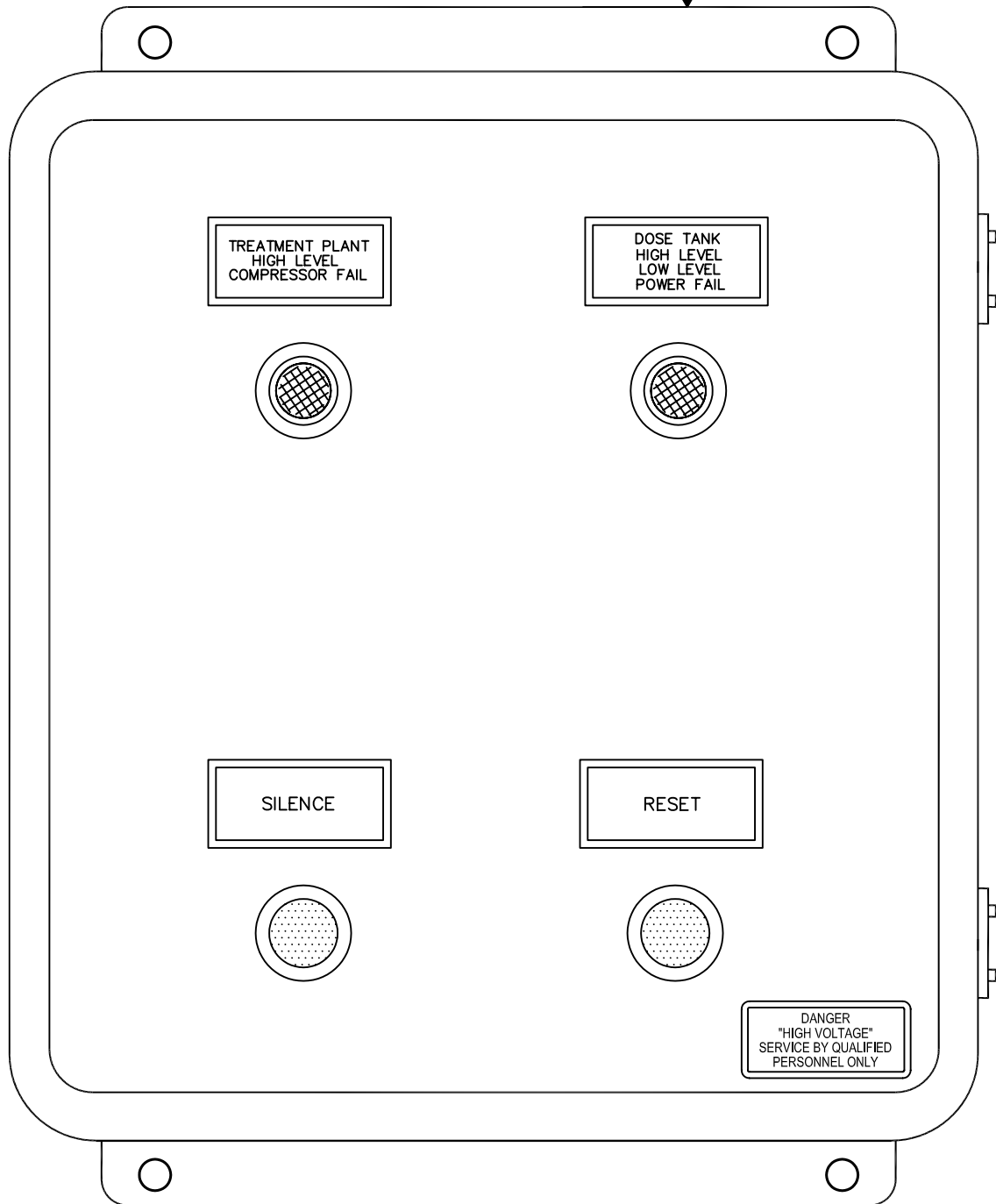

VIEW OF FRONT OF ENCLOSURE

Drawing Title									
ENCLOSURE									
DATE		REFERENCE DRAWING	NO.	REVISION-LOCATION	ECN	DATE	BY		
3/21/06		S/N	Sales Engineer	Application Engineer	DRAWN		APPROVED		
Project Title		C.C.	C.C.	R.C.	BY	C. RACHAL	BY	DATE	PURCHASE ORDER NUMBER
PUMP & COMPRESSOR CONTROL PANEL		COX Research and Technology, Inc.			P.O. Box 77808 Baton Rouge, LA 70809		DRAWING NUMBER CP-2056A		
		49			Ph. (225)756-3271 Fax (225)755-1030		SHEET NUMBER 2		

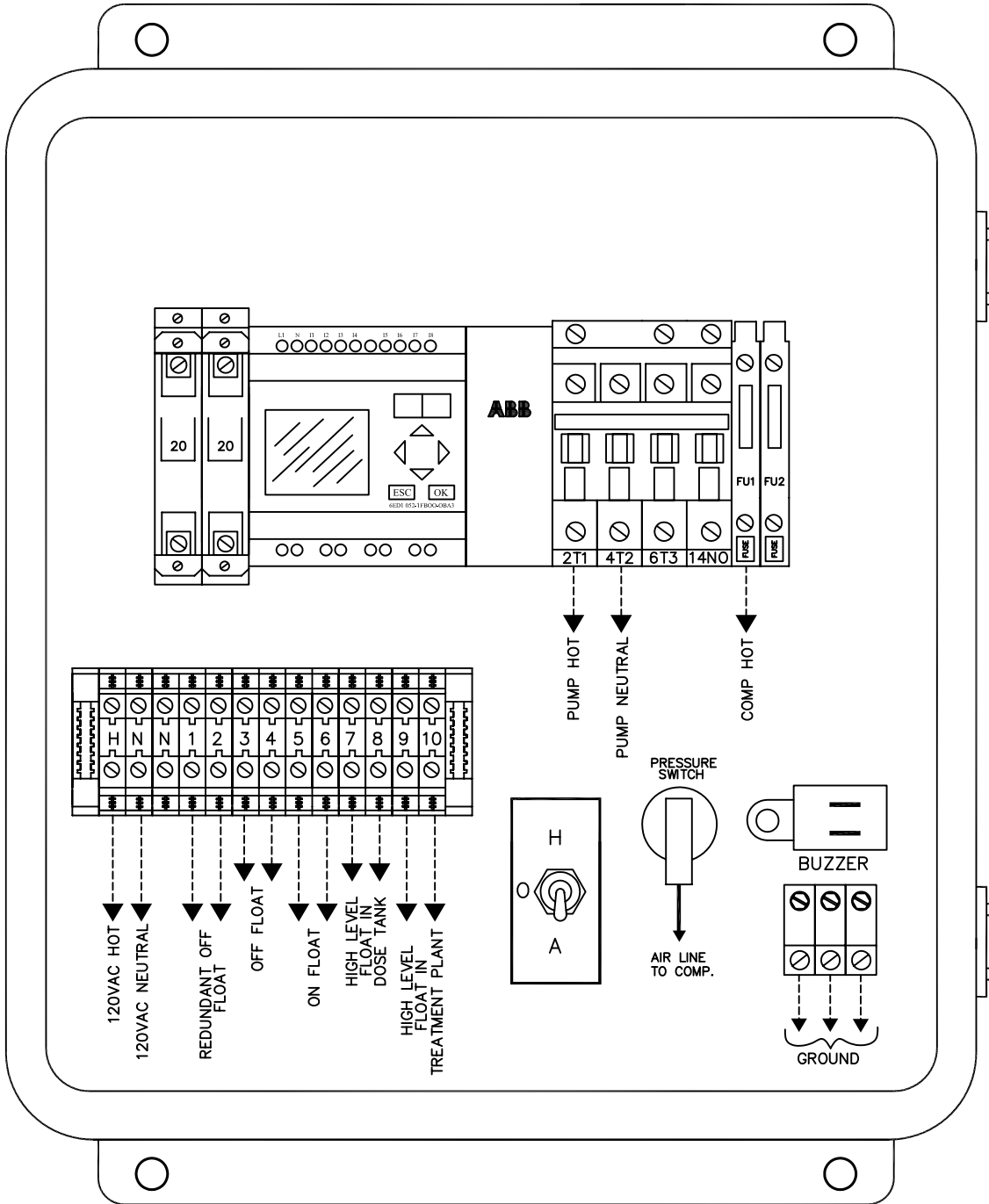

VIEW OF INTERIOR OF ENCLOSURE

Drawing Title									
ENCLOSURE									
DATE	3/21/06	REFERENCE DRAWING	NO.	REVISION-LOCATION	ECN	DATE	BY		
Project Title		Sales Engineer	Application Engineer	DRAWN		APPROVED			
PUMP & COMPRESSOR CONTROL PANEL		C.C.	R.C.	BY	C. RACHAL	BY	DATE	PURCHASE ORDER NUMBER	
		COX		P.O. Box 77808 Baton Rouge, LA 70809		DRAWING NUMBER		CP-2056A	
		Research and Technology, Inc.		Ph. (225)756-3271 Fax (225)755-1030		SHEET NUMBER		3	

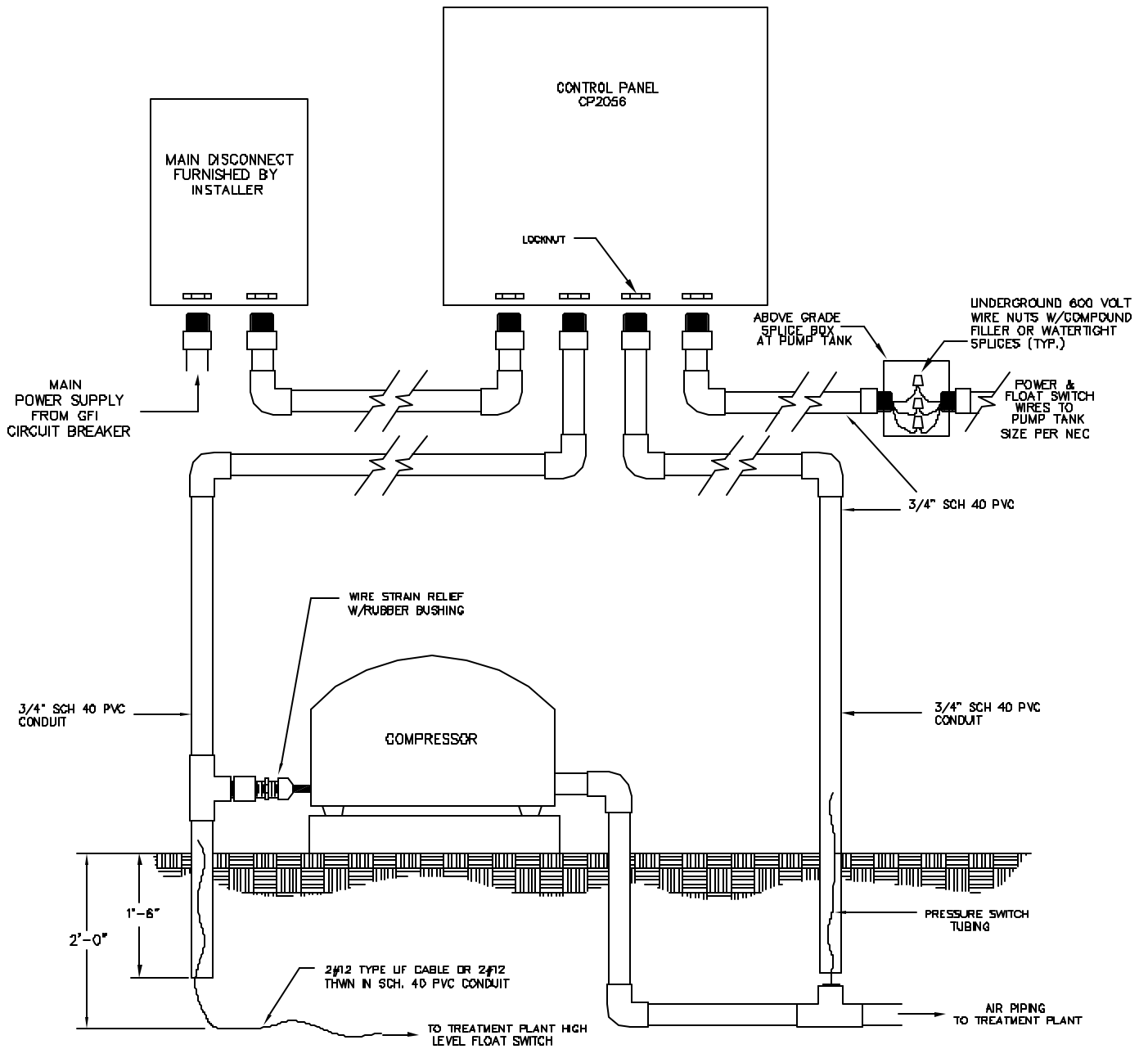

Delta Environmental Products, Inc.
P.O. Box 969 Denham Springs, LA 70727

Control Panel CP2056 Wiring Connections Using Linear Compressors

DWN BY:
C.C./C.RACHAL

DATE:
4/16/07

SCALE:
N.T.S.

DWG. NO.:
CRT625

JOB NO.:
N/A

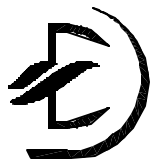
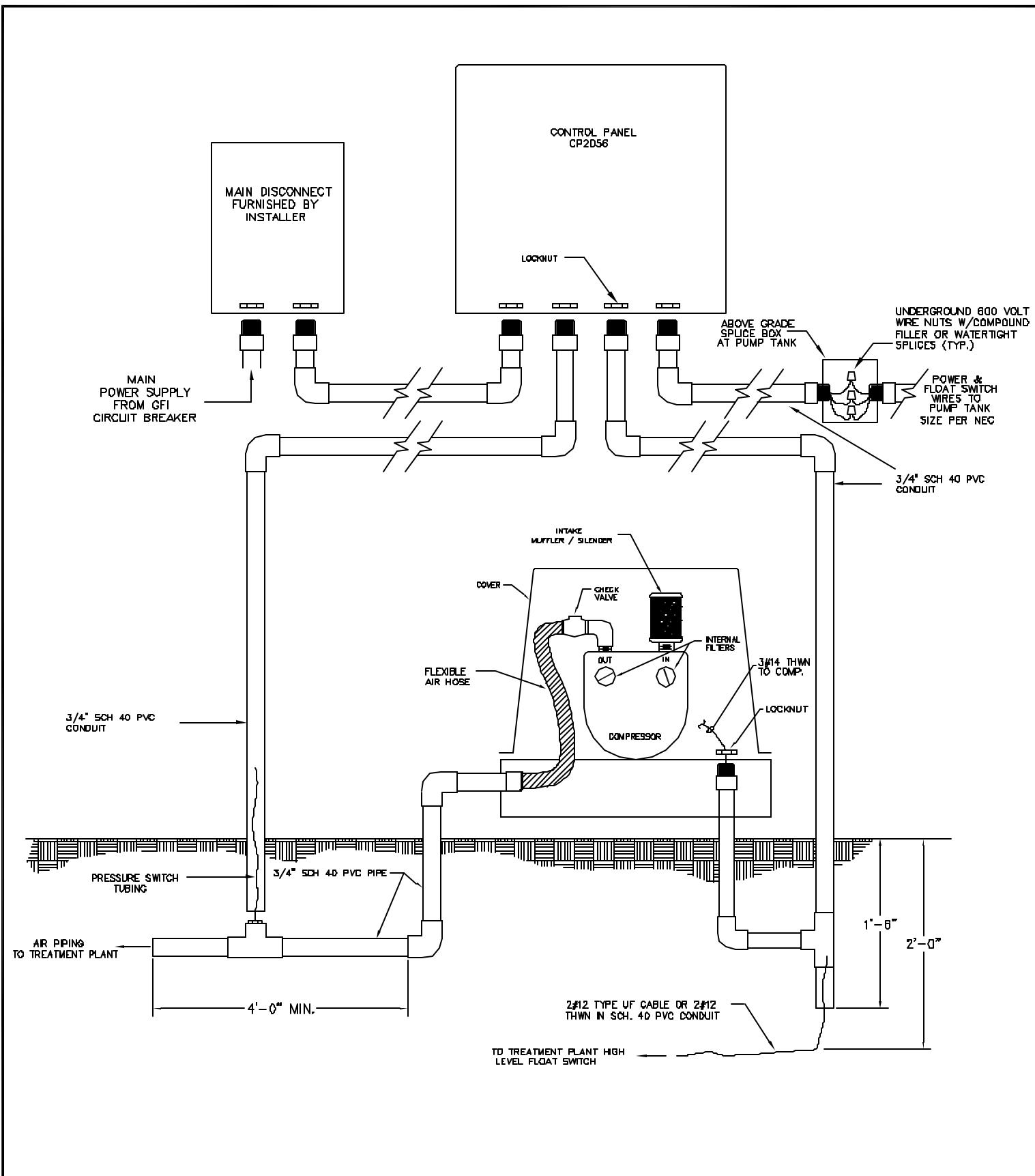

Delta Environmental Products, Inc.
P.O. Box 969 Denham Springs, LA 70727

Control Panel CP2056 Wiring Connections Using QR Series Compressors

OWN BY:
C.C./C.RACHAL

DATE:
4/16/07

SCALE:
N.T.S.

DWG. NO.:
CRT624

JOB NO.:
N/A

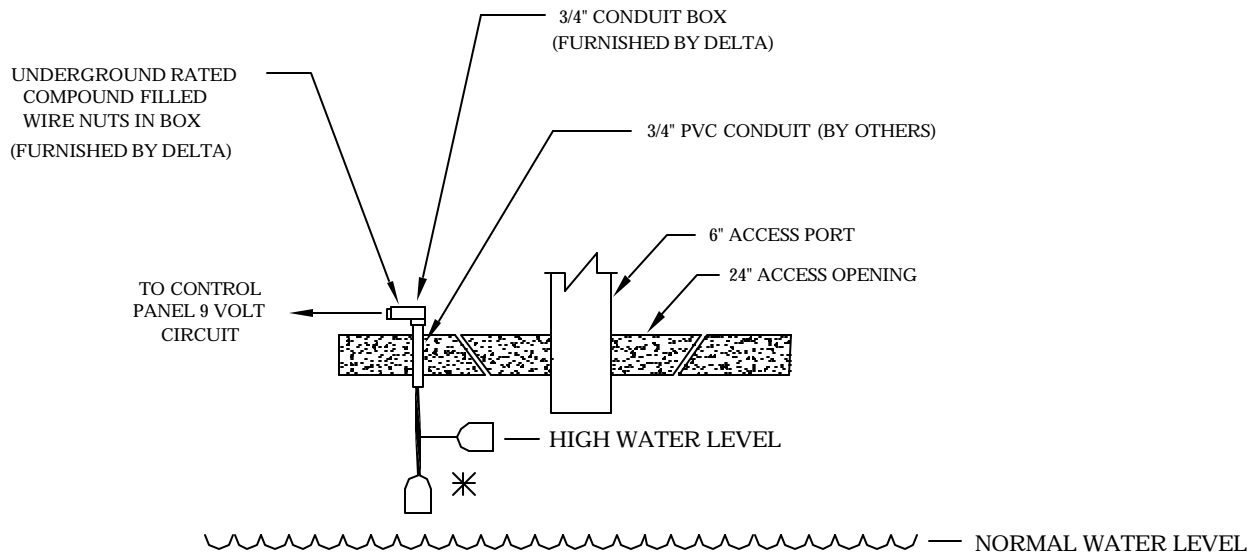
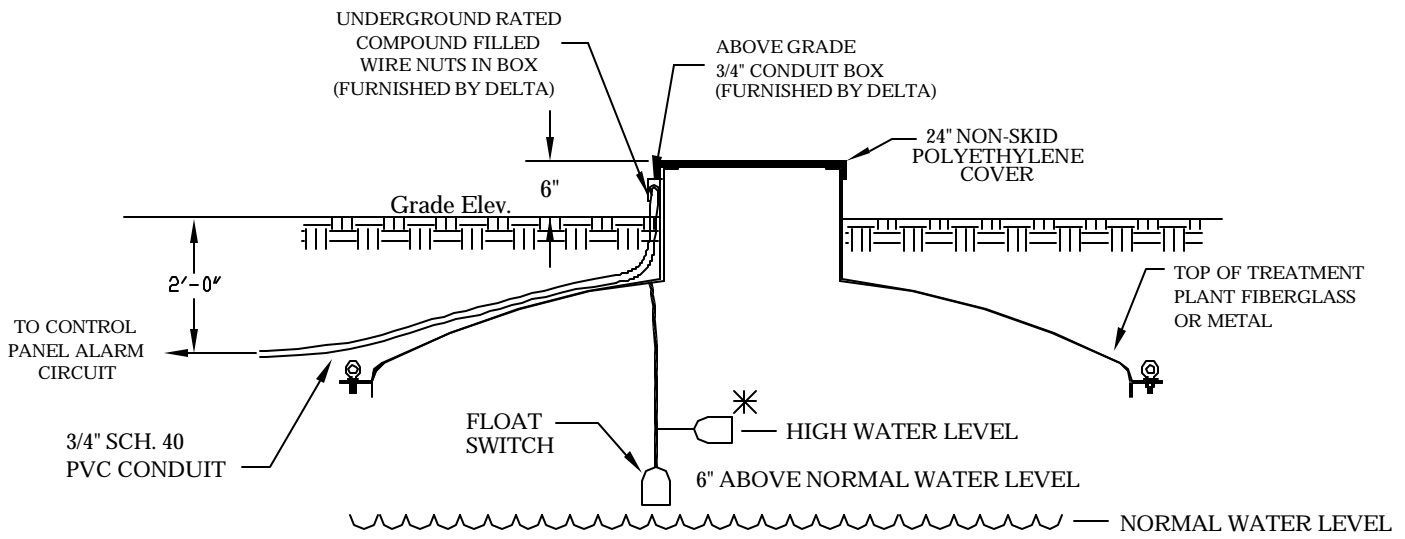

ENTRANCE INTO CONCRETE TANK

NOTES:

1. GROMMET TO BE SELECTED FOR TIGHT FIT AROUND CABLE AND IN LID.
2. WIRE TO CONTROL PANEL TO BE 18 GAUGE AND RATED FOR DIRECT BURIAL SERVICE. WOODS WIRE-886 OR EQUAL.
3. WIRE NUTS TO BE RATED FOR UNDERGROUND SERVICE IDEAL-DB PLUS MODEL 60 OR EQUAL.
4. FLOAT SWITCH TO BE NORMALLY OPEN MDI-AS10Y0500 OR EQUAL.
5. SMALL ACCESS PORT SHOWN ON DRAWING LARGE ACCESS PORTS MAY BE SUPPLIED.
6. MINIMUM AMOUNT OF CONDUIT SHOWN ABOVE IS REQUIRED EVEN WITH TYPE UF CABLE.



DELTA ENVIRONMENTAL PRODUCTS
P. O. BOX 969 DENHAM SPRINGS, LA 70727

FLOAT SWITCH MOUNTING

DWN BY:
C.RACHAL

DATE:
4/16/07

SCALE:
N.T.S.

DWG. NO.:
CRT611

ADDITIONAL MATERIALS NEEDED FOR CONTROL PANEL ELECTRICAL INSTALLATION

<u>QUANTITY</u>	<u>ITEM</u>	<u>MANUFACTURER OR EQUAL</u>
As required	2#12UF with ground	
2	300 volt silicon filled underground service wire nuts	King-6T
As required	Conduit and fittings are as shown in the drawings contained in this manual.	
1	20 amp minimum A/C Type disconnect switch or equal. Required on CP20 series panels only	

APPENDIX C
AIR PUMP DRAWINGS AND PARTS LIST

DRAWING & PARTS LIST

	MODEL 5078S 5080S 5100S 5120S	MODEL 5150S 5200S	MODEL 5078SE 5080SE 5100SE 5120SE	MODEL 5150SE 5200SE		
Item No.	Part No.	Part No.	Part No.	Part No.	Description	Qty.
1	C51800	C51802	C51800	C51802	Diaphragm Assembly	2
2	C52000	C52700	C52000	C52700	Head & Valve Assembly	2
3	C56301	C56302	-	-	Air Cleaner	1
4	C56002	C56005	-	-	Filter Cover Gasket	1
5	C53900	C53903	-	-	L-Tube	2
6	C50262	C50263	C50262	C50263	Protective Switch	1
7	C53008	C53009	-	-	Filter Cover	1
9	C50284	C50285	-	-	Tank Gasket	1

SHUTTLE ASSEMBLY (ITEM #)			
Model	Part No.	Qty.	
5078S, 5078SE	C50272	1	
5080S, 5080SE	C51800	1	
5100S, 5100SE	C51601	1	
5120S, 5120SE	C51802	1	
5150S, 5150SE	C51400	1	
5200S, 5200SE	C50285	1	

REBUILD KITS		
(KITS INCLUDE DIAPHRAGM ASSEMBLY AND HEAD & VALVE ASSEMBLY)		
(PART NOS. 1 & 2)		
Model	Part No.	Qty.
5078S, 5078SE 5080S, 5080SE 5100S, 5100SE 5120S, 5120SE	C50280	2
5150S, 5150SE 5200S, 5200SE	C50281	2

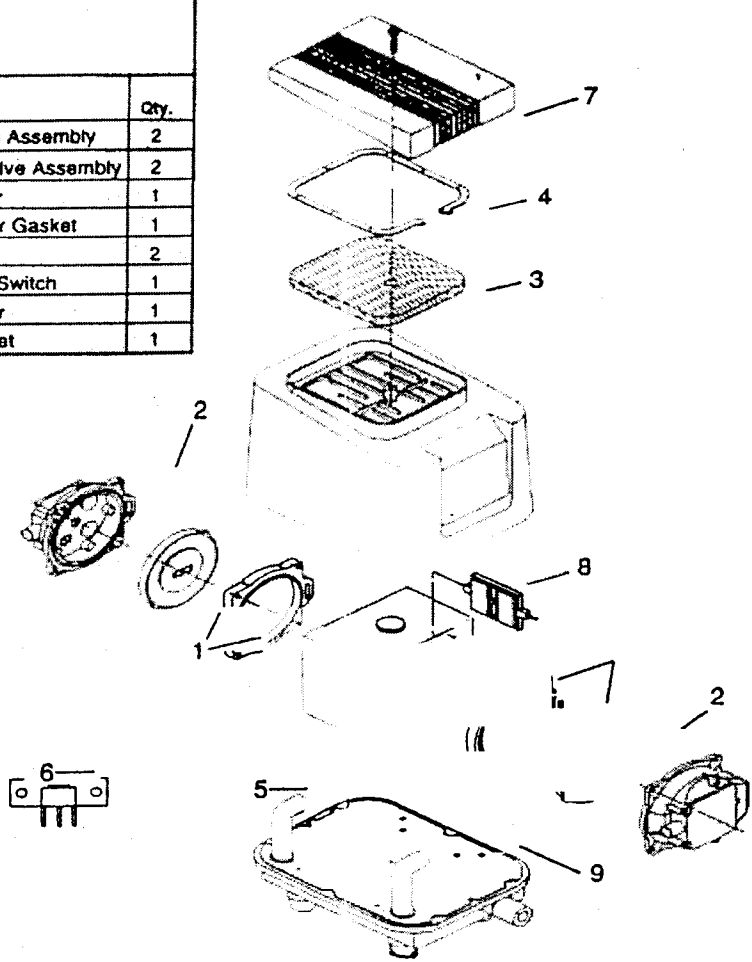

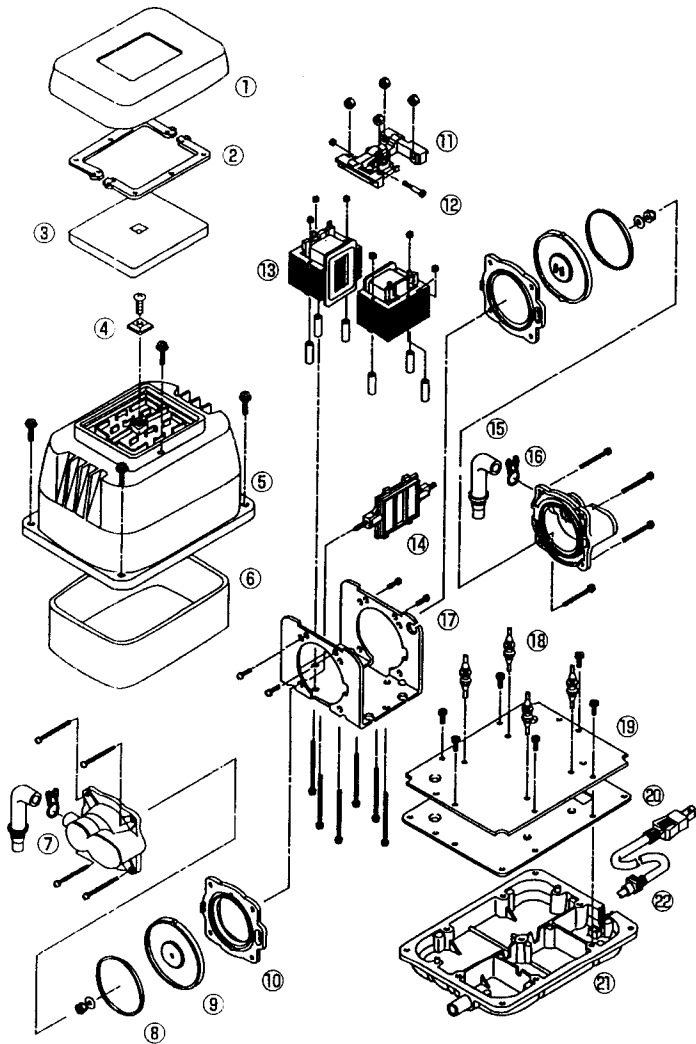

HP-60/80

- ① Filter Cover
- ② Semi Cover Packing
- ③ Filter
- ④ Fitting Boss
- ⑤ Upper Housing
- ⑥ Sound Absorber
- ⑦ Casing Block
- ⑧ Diaphragm Ring
- ⑨ Diaphragm
- ⑩ Diaphragm Base
- ⑪ SP Switch
- ⑫ Safety Screw
- ⑬ Electromagnet
- ⑭ Actuating Rod
- ⑮ L-Tube
- ⑯ Hose Band
- ⑰ Frame
- ⑱ Vibration Control Rubber
- ⑲ Center Plate
- ⑳ Gasket
- ㉑ Lower Housing
- ㉒ Power Cord

PARTS LIST

QR-0030

QR-0050

QR-0080

QR-0100

REF. NO.	DESCRIPTION	PART QTY.	291305 QR-0030	291306 QR-0050	291303 QR-0080	291304 QR-0100
1	SILENCER	1	C60362		C60363-P	
2	VANE KIT [(4) VANES, GASKET]	1	L32100-P		L32103-P	
3	ENDPLATE	1	L07163		L07166	
4	SOUND CHAMBER	1	L07164		L07165	
5	GASKET	1	L31058		L31059	
6	SHROUD	1	L38230		L38231	
7	FILTER KIT [(8) FELTS, (2) O-RINGS]	1	L84194-P		L84195-P	
8	MOTOR	1	L36236		L36235	
-	SHIM .0010 THICK	A/R*	L10556		L10569 (0.001)	
-	SHIM .0015 THICK	A/R*	L10557		L10570 (0.015)	
-	SHIM .0020 THICK	A/R*	L10558		L10571 (0.002)	

*AS REQUIRED

EXPLODED VIEW

QR-0030
QR-0050
QR-0080
QR-0100

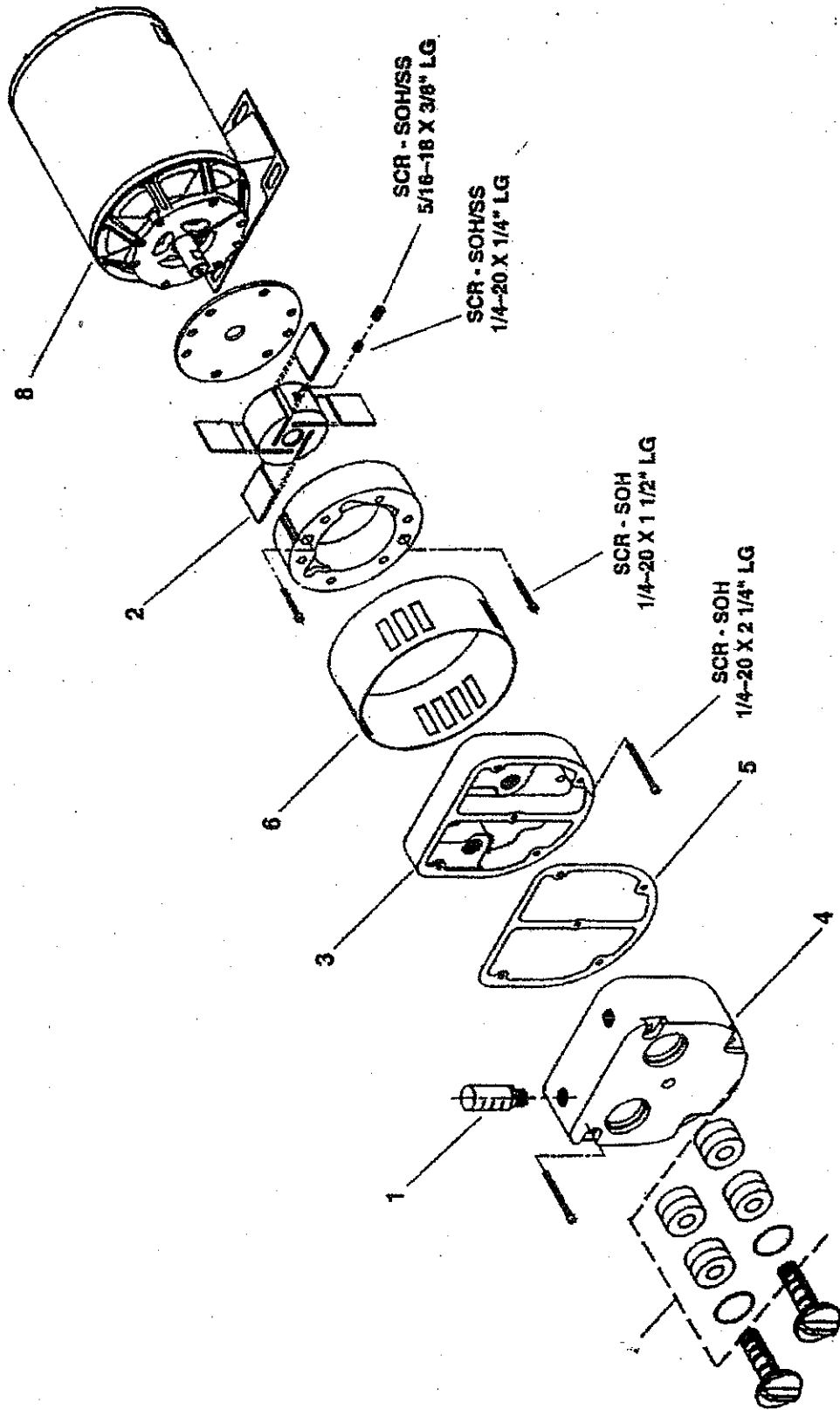

DRAWING & PARTS LISTS

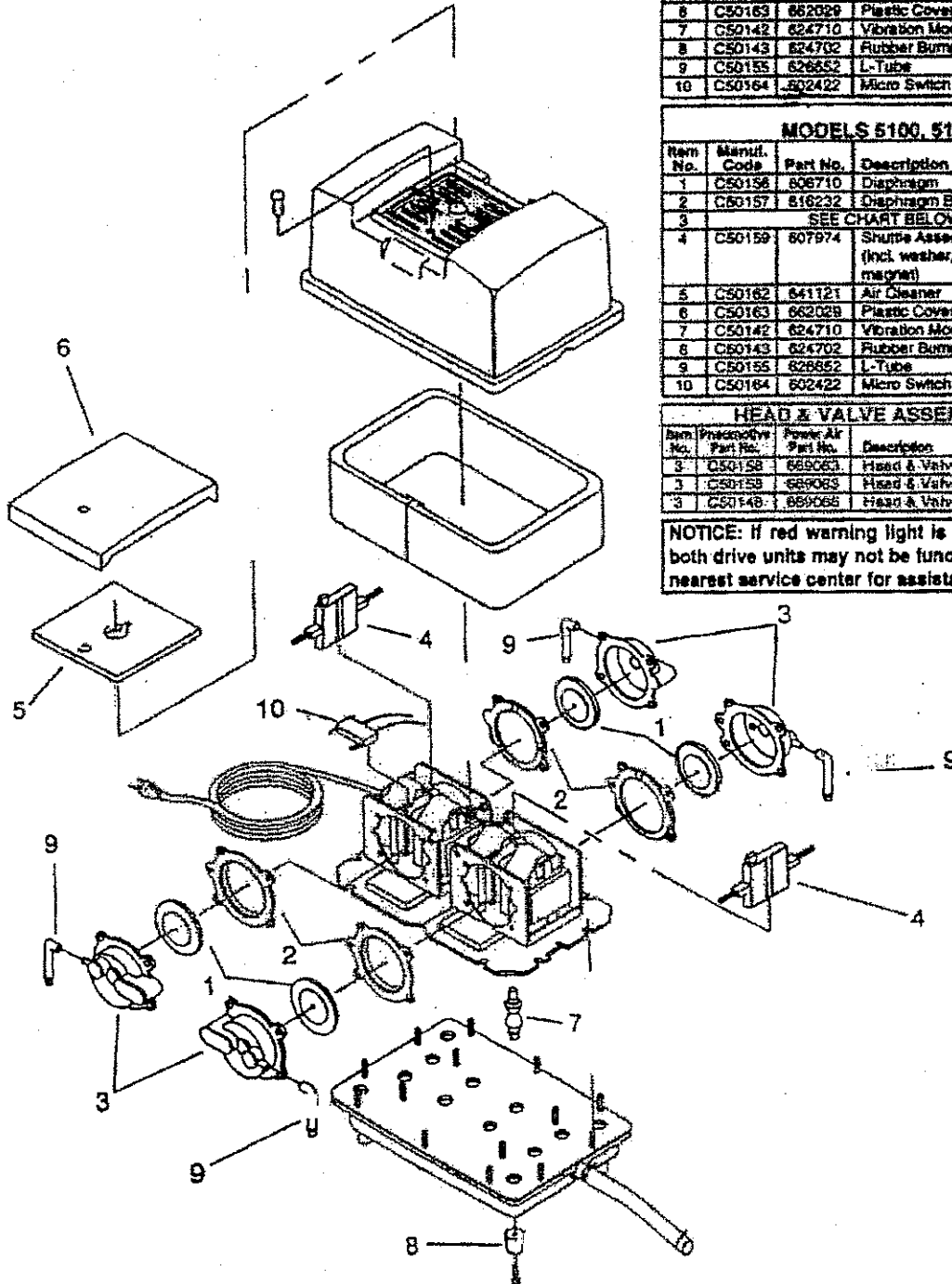

MODELS 5080				
Item No.	Manuf. Code	Part No.	Description	Qty.
1	C50145	808709	Diaphragm	4
2	C50157	818232	Diaphragm Base	4
3	SEE CHART BELOW			
4	C50151	807973	Shutoff Assembly (incl. washer, u-lock nut, magnet)	2
5	C50162	841121	Air Cleaner	1
6	C50163	882029	Plastic Cover (Air Cleaner)	1
7	C50142	824710	Vibration Mount	8
8	C50143	824702	Rubber Bumper	4
9	C50155	828852	L-Tube	4
10	C50164	802422	Micro Switch	2

MODELS 5100, 5120				
Item No.	Manuf. Code	Part No.	Description	Qty.
1	C50156	808710	Diaphragm	4
2	C50157	818232	Diaphragm Base	4
3	SEE CHART BELOW			
4	C50159	807974	Shutoff Assembly (incl. washer, u-lock nut, magnet)	2
5	C50162	841121	Air Cleaner	1
6	C50163	882029	Plastic Cover (Air Cleaner)	1
7	C50142	824710	Vibration Mount	8
8	C50143	824702	Rubber Bumper	4
9	C50155	828852	L-Tube	4
10	C50164	802422	Micro Switch	2

HEAD & VALVE ASSEMBLIES					
Item No.	Proective Part No.	Power Air Part No.	Description	Model No.	Qty.
3	C50158	889063	Head & Valve Assy.	5080	4
3	C50158	889063	Head & Valve Assy.	5100	4
3	C50148	889066	Head & Valve Assy.	5120	4

NOTICE: If red warning light is activated, one or both drive units may not be functioning. Call your nearest service center for assistance.

APPENDIX D DATA PLATES

TREATMENT PLANT DATA PLATES

4"

WHITEWATER
Delta Environmental Products™
Pentair Water
8275 Florida Boulevard
Denham Springs, LA 70726
Phone: 1-800-219-9183
Model DF XXX-X
ANSI/NSF STD 40
XXX GPD Class I

Serial No.



2"

4"

ALARM MALFUNCTION ELECTRICAL PANEL

WHITEWATER
Delta Environmental Products™
Pentair Water
8275 Florida Boulevard
Denham Springs, LA 70726
Phone: 1-800-219-9183
Model DF XXX-X
ANSI/NSF STD 40
XXX GPD Class I

Serial No.



3"

APPENDIX E
SERVICE POLICY, WARRANTIES
AND INSPECTION COUPONS

DELTA ENVIRONMENTAL PRODUCTS INDIVIDUAL MECHANICAL WASTEWATER TREATMENT SYSTEM SERVICE POLICY

INITIAL POLICY:

A two year initial service policy shall be furnished to the user by the manufacturer or the distributor through the dealer. This policy is to be included in the purchase price from the seller of the system and shall provide the following:

1. **An inspection/service call every six months**, which includes inspection, adjustment, and servicing of the mechanical and electrical component parts as necessary to ensure proper function.
2. An effluent quality inspection every six months consisting of a visual check for color, turbidity, scum overflow, and an examination for odors.
3. If any improper operation is observed which cannot be corrected at that time, the user shall be notified immediately in writing of the conditions and the estimated date of correction. **THIS POLICY DOES NOT INCLUDE PUMPING SLUDGE FROM UNIT IF DEEMED NECESSARY.**

CONTINUING SERVICE POLICY:

An annually renewable service policy affording the same coverage as the Initial Service Policy is available. Consult your dealer for pricing information.

PARTS:

Replacement parts or components may be obtained from your local distributor or contact Delta Environmental Products™ for information.

COMPLAINTS:

In order for Delta Environmental Products™ to properly address complaints, we require that you put in writing the date and nature of the complaint as detailed as possible. This must include the Serial Number of your system.

Send to: Delta Environmental Products™
P.O. Box 969
Denham Springs, LA 70727-0969

LIMITED WARRANTY

Delta Environmental Products™ warrants the parts in each treatment system as follows: air pump: limited pro-rated five (5) years - first two (2) years 100 %, third (3) year 75 %, fourth (4) year 50 %, fifth (5) year, 25 %), **The 3, 4, and 5 year pro-rated portion of this warranty is only valid with a continuing Service Policy in effect. Proof of this continuing Service Policy must be provided.** QR-Rotary compressor – limited 2 years, SAR – Rotary compressor – limited 3 years, fiberglass tanks: limited 10 years, metal tanks: limited 2 years, and concrete tanks: limited 2 years. All warranty questions shall be resolved through Delta Environmental Products™. The warranty on the treatment device is that the device is free from defects in material and workmanship from the date of installation treating household wastewater. Some states do not allow limitations on how long an implied warranty lasts, so the above limitation may not apply. Sole obligation under this warranty is as follows: Delta Environmental Products™ shall fulfill this warranty by repairing or exchanging any component part, F.O.B. factory that in Delta Environmental Products™ judgment shows evidence of defects, provided said component part has been paid for and is returned through an authorized dealer, transportation prepaid. The warrantee must also specify the nature of the defect to the manufacturer.

The warranty does not cover treatment processes/devices that have been flooded, by external means, or that have been disassembled by unauthorized persons, improperly installed, subjected to external damage or damaged due to altered or improper wiring or overload protection.

This warranty applies only to the treatment process/device and does not include any of the house wiring, plumbing, drainage, or disposal system. Delta Environmental Products™ is not responsible for any delay or damages caused by defective components or material, or for loss incurred because of interruption of service, or for any other special or consequential damages or incidental expenses arising from the manufacture, sale or use of this process/device.

Delta Environmental Products™ reserves the right to revise, change or modify the construction and design of the treatment process/device for household wastewater or any component part or parts thereof without incurring any obligation to make such changes or modifications in previously sold equipment. Delta Environmental Products™ also reserves the right, in making replacements of component parts under this warranty, to furnish a component part which, in its judgment is equivalent to the part replaced.

Under no circumstances will Delta Environmental Products™ be responsible to the warrantee for any other direct or consequential damages, including but not limited to lost profits, lost income, labor charges, delays in production, and/or idle production, which damages are caused by a defect in material and/or workmanship in its parts. Some states do not allow the exclusion of limitation of incidental or consequential damages, so the above limitation or exclusion may not apply to you.

This warranty is expressly in lieu of any other express or implied warranty, excluding any warranty of merchantability or fitness and of any other obligation on the part of Delta Environmental Products™.

This warranty gives you specific legal rights, and you may also have other rights which vary from state to state.

Pentair Water
Flow Technologies
8275 Florida Blvd.
Denham Springs, LA 70727
225.665.6162
225.664.9467 Fax
800.219.9183 Toll Free



2-Year Service Contract For the State of Oregon

Parties: (Authorized Delta Service Provider)

Name: _____
Address: _____

Telephone: _____
Fax: _____
Email: _____

And: (Customer)

Name: _____
Address: _____

Telephone: _____
Fax: _____
Email: _____

System Location:

Address: _____

Legal Description: _____
GPS Coordinates: _____

Installed by: _____

Serial Number: _____

Agency Contact Information:

Agency: _____

Address: _____

Telephone: _____

Fax: _____

Email: _____

Date: _____

NOW, THEREFORE, in consideration of the terms, provision, covenants and conditions herein, the Parties hereto agree as follows:

1.0 Performance of Basic Services

1.1 Initial Service Policy

The Authorized Delta Service Provider shall perform the System Inspection/Service Visits during the 24-month period after installation, as marked:

Inspection/Service Visits ¹	6 th month	<u>1</u>
	12 th month	<u>1</u>
	18 th month	<u>1</u>
	24 th month	<u>1</u>

¹*As required by NSF, these services will be included as part of the initial purchase of the system.*

These services shall be performed during normal business hours Monday through Friday (excluding national holidays) on a pre-scheduled basis and as the Authorized Delta Service Provider deems necessary or advisable.

At each service visit the System shall be inspected and serviced in accordance with the instructions in the Systems O & M Manual. Additionally, as effluent quality inspection consisting of a visual assessment of color, turbidity, and scum overflow and an olfactory assessment for odor shall be

performed.

The Service Provider will affix a "For Service, Call _____" label near the control panel's alarm signal and fill in his or her phone number.

Performance of the 2-year Inspection/Service visits shall include notification of needed repair, replacement or addition of parts used in the system.

The Service Provider shall be responsible for submitting the annual report and annual evaluation fee to the appropriate regulatory agency as required in OAR-071-0345.

The Service Provider shall notify the owner in writing if any improper system operation cannot be remedied at the time of servicing. The written notification shall include an estimated date of correction.

1.2 Extended Service Policy

The Delta Authorized Service Provider shall make available for purchase by owner an extended service policy with terms comparable to those in the initial service policy.

1.3 Stand By Parts

In the event that a mechanical or electrical component must undergo off site repairs the local authorized representative should maintain a stock of mechanical and electrical components that may be temporarily installed until repairs are completed.

1.4 Availability of Service

The service provider shall provide emergency service within 48 hours of service request.

2.0 Term of Agreement

The agreement shall be for the period 24 months from the date of the system start up unless otherwise terminated or cancelled by either party as provided herein

3.0 Definitions

For purposes of this agreement the following definitions shall apply:

3.1 System shall mean a Delta ANS/NSF 40 certified wastewater treatment system.

3.2 "System Start-Up Date" shall mean the date the System begins operating for its intended purpose.

4.0 Charges

The basic services including service, inspection, effluent quality evaluation, and service, shall be included with the purchase of the System, Optional, additional services shall be provided at the

agreed upon contract price and terms. The annual report and annual evaluation fee required by DEQ is not optional, and may or may not be included in the cost of basic services. Refer to Service Providers fee schedule for an outline of the cost of basic services and optional services to be provided under this contract.

5.0 Warranty

The Delta Service provider warrants that all services shall be performed in a good and workmanlike manner and that service provider will correct any system errors, malfunctions, defects directly caused by service provider's failure to perform the services and additional services in such manner.

6.0 Limitation of Liability

The sole liability of the Service Provider under this agreement shall be to correct any errors, malfunctions, or defects in the system directly caused by the Delta Service Providers failure to perform any services in good and workmanlike manner pursuant to section 4 above. In no event should the Service provider's liability to the customer hereunder exceed the total of the amounts paid to the service provider hereunder by the customer. In no event shall the Delta Service Provider be liable to the customer or any other third party claimant for any indirect, special, punitive, consequential or incidental damages or lost profits arising out of or related to this agreement or the performance or breach thereof, whether based upon a claim or action of contract, warranty, negligence, or strict liability or other tort. Breach of any statutory duty, indemnity or contribution or otherwise, even if the service provider has been advised of the possibility of such damage.

7.0 Termination/Cancellation

This agreement may be terminated or cancelled only upon:

- Written notice by one Party effective as of the effective date thereof if the other Party is in default of any provision of this Agreement and such default is not cured by the defaulting Party within fifteen (15) days after the effective date of said notice from the non-defaulting party, or by the mutual agreement of both Parties.
- Copy of such written notice shall be forwarded to the regulatory agency.

8.0 Miscellaneous Provisions

This agreement is personal in nature and may not be delegated, assigned or transferred by either Party without the prior written consent of the other Party.

The laws of the State of Oregon shall govern the Agreement.

The homeowner shall be responsible for complying with the Delta DF Series Installation, Operation & Maintenance Manual provided to them with the purchase of the system.

Any notice or other communication required or permitted to be given under this Agreement shall be in

writing and shall be mailed by certified mail, return receipt requested, postage prepaid, addressed to the Parties at the addresses shown on the first page of the Agreement. Any notice or other communication shall be deemed given at the expiration of the second day after the date of deposit in the United States mail. The addresses to which notices or other communications shall be mailed may be changed from time to time by giving written notice to the other Party as provided in this Section.

Value of maintenance contract \$150.00 per year, total of \$300.00 for 2 years included in sale of system. State/County fees of approximately \$50.00 included in this price. Inspection and maintenance of the pump basin and pump apparatus following the Whitewater Treatment System included in this contract. We will observe and record conditions of drain field as per State requirements.

Delta Service Provider

Name

Signature

Oregon Certified Service Provider

Title

Customer

Name(s)

Signature(s)

Title



Mandatory inspection sheet				
Service contract				
Customers			Configuration	
			One, Two or Three	
A. Maintain 1000 Gallon processing tank				
			Frequency	Gravity System
				Pump Out
1)	Visual inspect for infiltration		Semi-Annual	
2)	Measure sludge and scum		Annual	
3)	Recommend tank pumping when necessary		Semi-Annual	
B. Maintain Delta Product				
1)	Inspect for ponding		Semi-Annual	
2)	Air Vent (intact and clear)		Semi-Annual	
3)	Air unit Operation and clean filter		Semi-Annual	
4)	Check for odor (Sniff)		Semi-Annual	
5)	Check for film (Visual inside tank)		Semi-Annual	
6)	Check for foam(visual inside tank)		Semi-Annual	
C. Maintain disposal field pump basin				
			Inspect Disposal Field	
1)	Check pump intake		Semi-Annual	
2)	Check float for proper operation		Semi-Annual	
3)	Visually inspect surface for ponding		Semi-Annual	
4)	Check monitoring wells liquid level		Semi-Annual	
5)	Visually Inspect Basin Infiltration		Semi-Annual	
6)	Check Basin still Level		Semi-Annual	
7)	Visually Inspect drain field for ponding		Semi-Annual	