

ECOLOGICAL TANKS, INC.

AQUA  SAFE [®]

“The standard by which the performance of other units is compared”[®]

Class I Wastewater Treatment Plants

**Installation, Operation, Maintenance and Trouble-Shooting
Manual for Distributors, Installers, and Maintenance
Providers**

(Oregon Version)

MODELS

AS500L

AS600L

AS1100L

“Copyright Notice”

No part of this publication may be reproduced, stored in any retrieval system, or transmitted in any form or by any means, electronic, mechanical, photocopying, recording, or otherwise without the prior written permission of Ecological Tanks, Inc.



**Mfg. By
Ecological Tanks, Inc.
2247 Highway 151 North
Downsville, LA 71234
PH (318) 644-0397 • FAX (318) 647-7257**

I. INTRODUCTION

Ecological Tanks, Inc. was founded in 1994 by people with combined experience in installation, pre-casting and the building industry. At **Ecological Tanks, Inc.** our main goal is to provide products to professionals engaging in the business of distributing, installing and servicing home wastewater treatment plants. To continue our service, we have dedicated ourselves to manufacturing versatile products to simplify the task of installation and maintenance. This will include all-in-one aerobic systems, the first one box control for the operation of pumps and compressors, unique upsize controls and other products that are first in the on-site sewage industry. With this unique diversity and know how, we can provide the help you need with your on-site sewage treatment business.

Model AS500L (low profile) and larger plants in this series have been tested by NSF and also meet or exceed the Class 1 plant characteristic requirements. This model series was tested without a trash trap, but may utilize one as an option to comply with state/local requirements, or to reduce maintenance. The AS500L, AS600L and AS1100L are approved for use in the State of Oregon. Note: A minimum of 1000 gallon pre-treatment (septic) tank is required on all installations in the State of Oregon (Oregon Administrative Rule 340-071-0220(3)(a).

II. AQUA SAFE® WASTEWATER TREATMENT PLANT PROCESS DESCRIPTION

Aqua Safe® series models of wastewater treatment plants are made with an outer mixing compartment and a center settling or clarifier compartment. They are in many ways similar to large township or municipality sewage treatment plants. They employ an extended aeration, activated sludge process. This type of treatment depends primarily upon the use of air that is introduced by air passing from the aerator compressor to four air lines located around the perimeter of the aeration mixing compartment. As wastewater enters the aeration mixing compartment, simple hydraulic displacement is accomplished by the introduction of air which promotes the growth of aerobic organisms in much larger quantities than would occur naturally. These bacteria break down the organic solids in the wastewater. From the aeration mixing compartment, mixed liquid enters the cone-shaped settling or clarifier compartment from the bottom. No mixing occurs in this quiet zone where solids separate from liquid and settle to the bottom of the clarifier and re-enter the mixing compartment. The liquid that separates from the solids in the clarifier continue to flow upward to the discharge pipe.

The **Aqua Safe®** Models **AS500L**, **AS600L** and **AS1100L** (Figures 1 - 5) are round tank configurations comprised of an aeration mixing compartment and a center clarifier compartment.

The results of the **Aqua Safe®** process are a clear, odorless effluent discharge which meets and exceeds state and national water quality standards.

AQUA SAFE® PRODUCT SPECIFICATIONS
INDIVIDUAL HOME WASTEWATER TREATMENT PLANTS

MODELS AS500L, AS600L, AS1100L

	AS500L	AS600L	AS1100L
Treatment Capacity	500 GPD	600 GPD	1100 GPD
Volumetric Capacity	908 GAL.	1058 GAL.	2008 GAL.
Aeration Zone Capacity	756 GAL.	881 GAL.	1705 GAL.
Clarifier Capacity	152 GAL.	177 GAL.	302 GAL.
BOD₅ Loading	1.25#/DAY	1.50 #/DAY	2.5 #/DAY
Aerator - Aqua Safe® Compressor	ASC2532	ASC3352	ASC7510

DESIGN COMPONENTS AND MATERIALS

Aeration Tank and Cover.....fiberglass or concrete
 Clarifier.....polyethylene or fiberglass
 Compressor Housing.....polyethylene, fiberglass or concrete

PARTS LIST

Aeration Tank Fiberglass or Concrete.....Item #1
 Clarifier Fiberglass.....2
 Air Distribution System.....3
 Access Cover 20" Polyethylene or Concrete.....4
 Discharge Piping Assembly.....5
 Compressor Housing.....6

MODEL	DIMENSIONS	
	A (I.D.)	B (HEIGHT)
AS500L	6'	5'
AS600L	6"	5'9"
AS1100L	6'9"	8'2"

Ecological Tanks, Inc.
 Aqua Safe Model
 AS500L-EZ

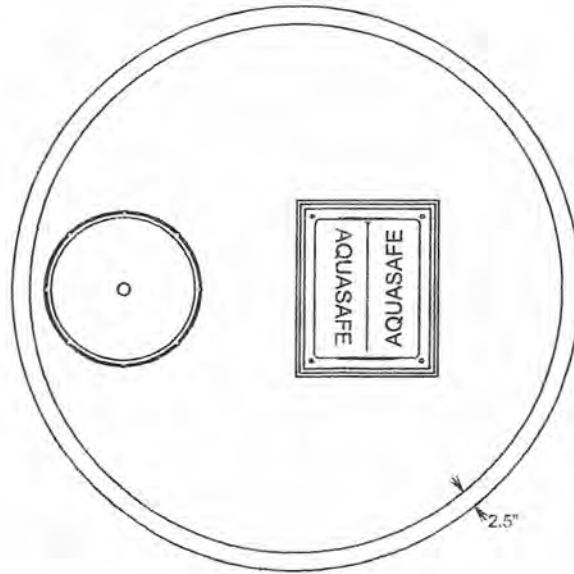

TOP VIEW

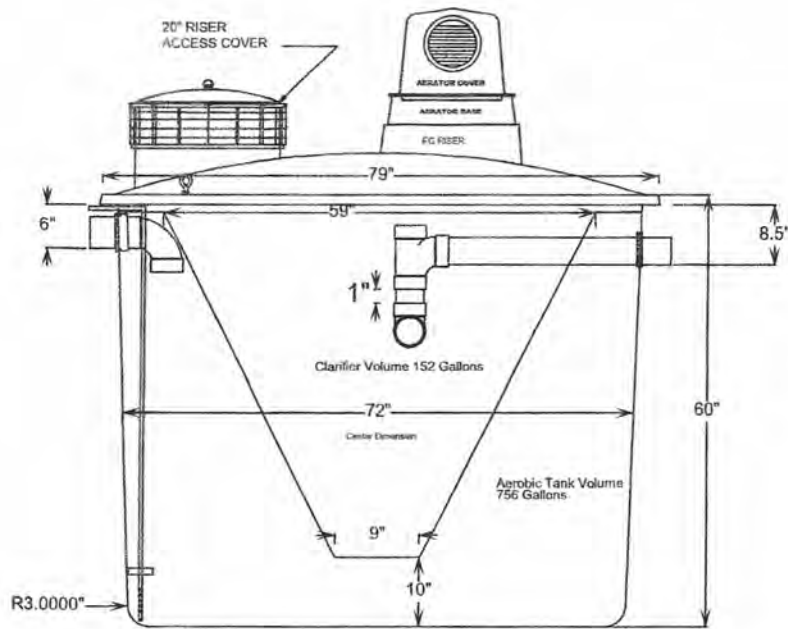

NOTES:

- Total Tank Volume: 908 Gallons to flow line
- Tank Taper from Flange to Bottom: 4 inches
- Aerobic and Clarifier Volumes measured at flow line

FIGURE 1

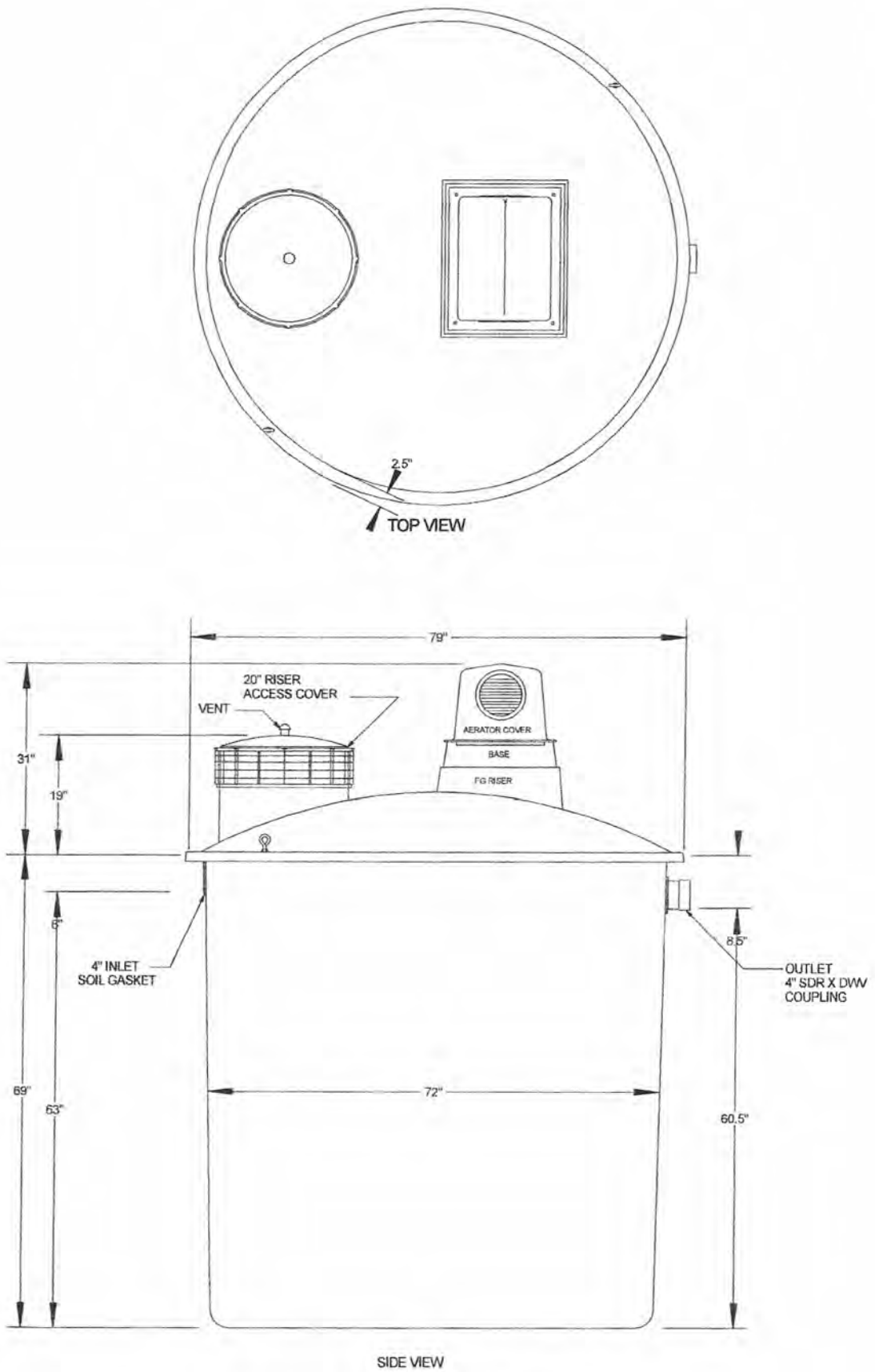

ALL DIMENSIONS IN INCHES

DESCRIPTION: MODEL AS600L-EZ				
Treatment Capacity: 600 GPD		Flow Line Volume: 1056 GAL.		
DWG REF: D-TA600L-EZ	REV: 0	DATE: 09/24/2008	SCALE: FULL	ENG: JKC
ECOLOGICAL TANKS, INC 2247 HWY 151 NORTH DOWNSVILLE, LA 71234 318-644-0367 OFFICE 318-644-7257 FAX		NO PART OF THIS DRAWING MAY BE REPRODUCED, STORED IN ANY RETRIEVAL SYSTEM, OR TRANSMITTED IN ANY FORM OR BY ANY MEANS, ELECTRONIC, MECHANICAL, PHOTOCOPIING, RECORDING OR OTHERWISE WITHOUT THE PRIOR WRITTEN PERMISSION OF ECOLOGICAL TANKS, INC.		

FIGURE 2

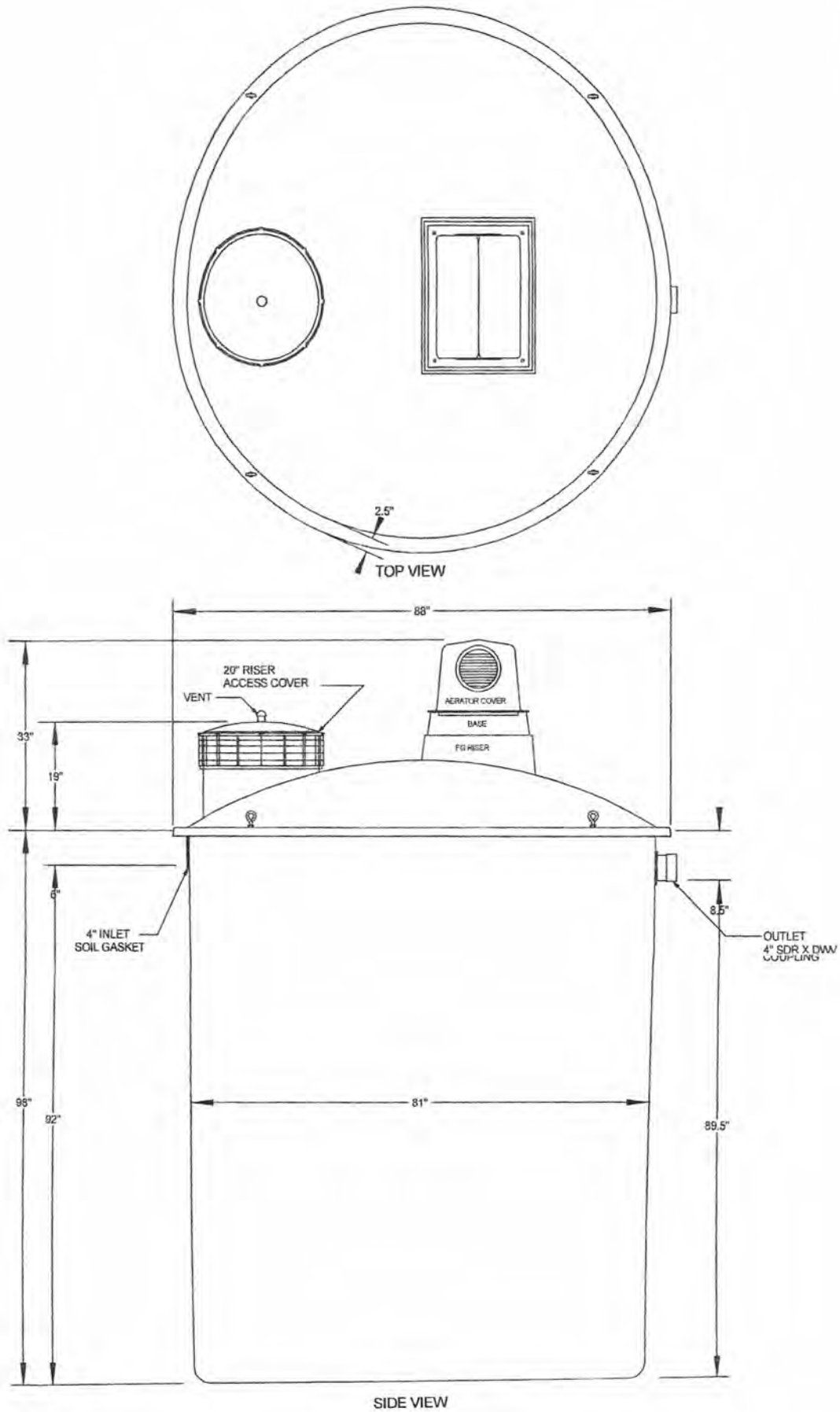

ALL DIMENSIONS IN INCHES

DESCRIPTION: MODEL AS1100L EZ		Flow Line Volume: 1985 GAL.	
Treatment Capacity: 1100 GPD			
DWG REF: DTA-1100	REV: 0	DATE: 06/12/2008	SCALE: FULL
ECOLOGICAL TANKS, INC. 2247 HWY 151 NORTH EDWARDSVILLE, LA 71234 318-644-0387 OFFICE 318-644-1257 FAX		NO PART OF THIS DRAWING IS TO BE REPRODUCED, STORED IN ANY RETRIEVAL SYSTEM OR TRANSMITTED IN ANY FORM OR BY ANY MEANS ELECTRONIC, MECHANICAL, PHOTOCOPIING, RECORDING OR OTHERWISE WITHOUT THE WRITTEN PERMISSION OF ECOLOGICAL TANKS, INC.	

FIGURE 3

Ecological Tanks, Inc.
Aqua Safe Model
AS500L-C

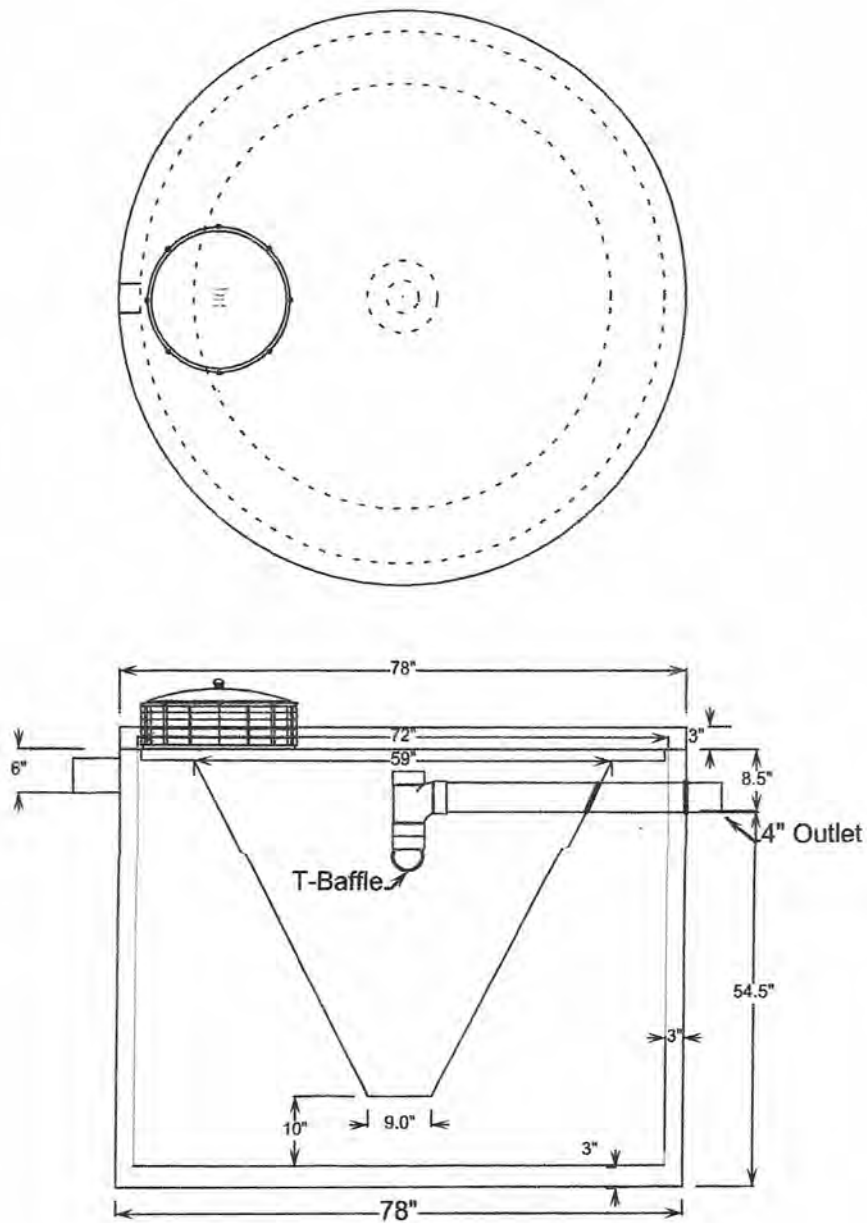

Reinforcement Notes:

SIDES & BOTTOM: 6x6 10/10 W.W.F.
4000 PSI CONCRETE

TOP: 6x6, 10/10 W.W.F. AND
3/8" RODS 9" O.C. EACH WAY

4000 PSI CONCRETE

NOTES: START REINFORCING RODS 6"
FROM OUTSIDE EDGE OF TOP

EXTEND REINFORCING RODS TO WITHIN
1/2" OF EDGE OF TOP

FIGURE 4

AS600L-C AS1100L-C

Concrete Aerobic Treatment Plant

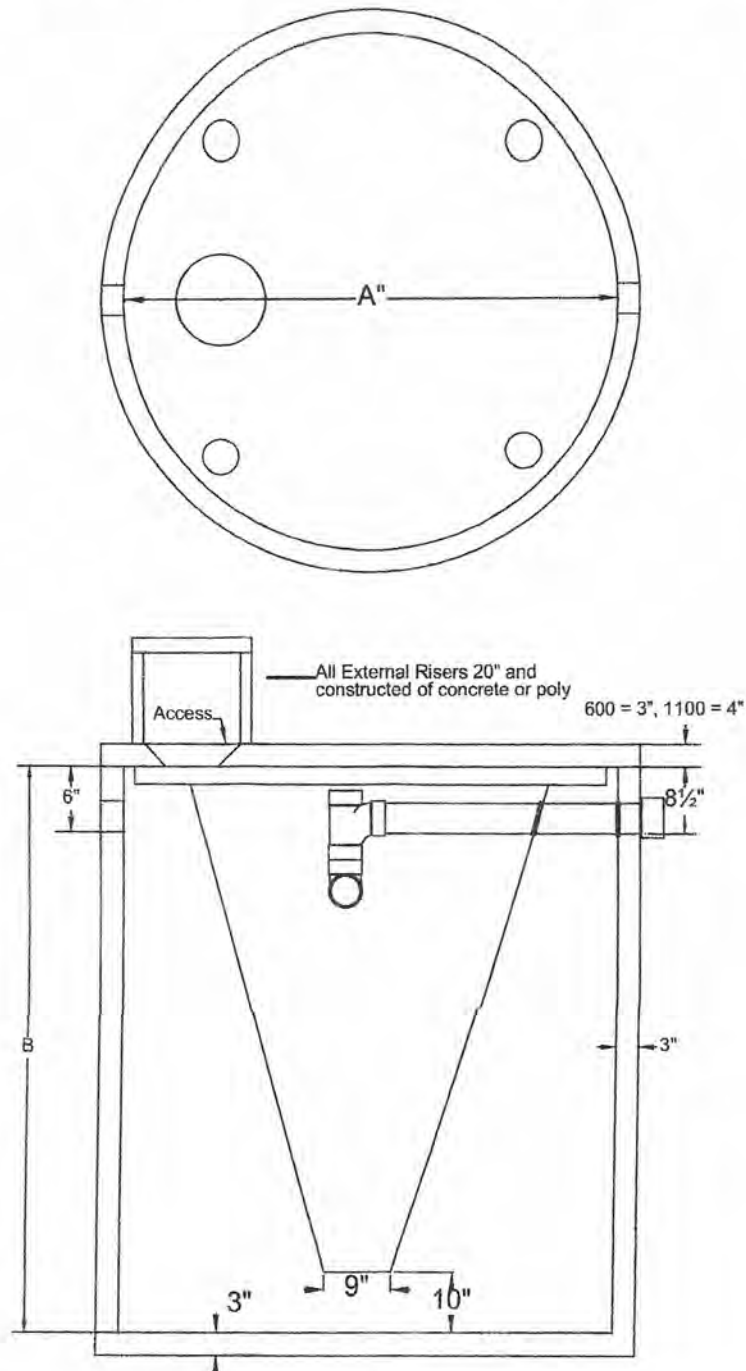

Schedule

	AS600L-C	AS1100L-C
Treatment Capacity	600 GPD	1100 GPD
Volumetric Capacity	1,241 Gal.	2,159 Gal.
Aeration Volume - Water Line	881 Gal.	1,638 Gal.
Clarifier Volume - Water Line	177 Gal.	327 Gal.
Total Volume - Water Line	1,058 Gal.	1,965 Gal.
Inside Diameter (A)	72"	80.5"
Inside Height (B)	69"	98"
BOD Loading (# per Day)	1.50	2.75

FIGURE 5

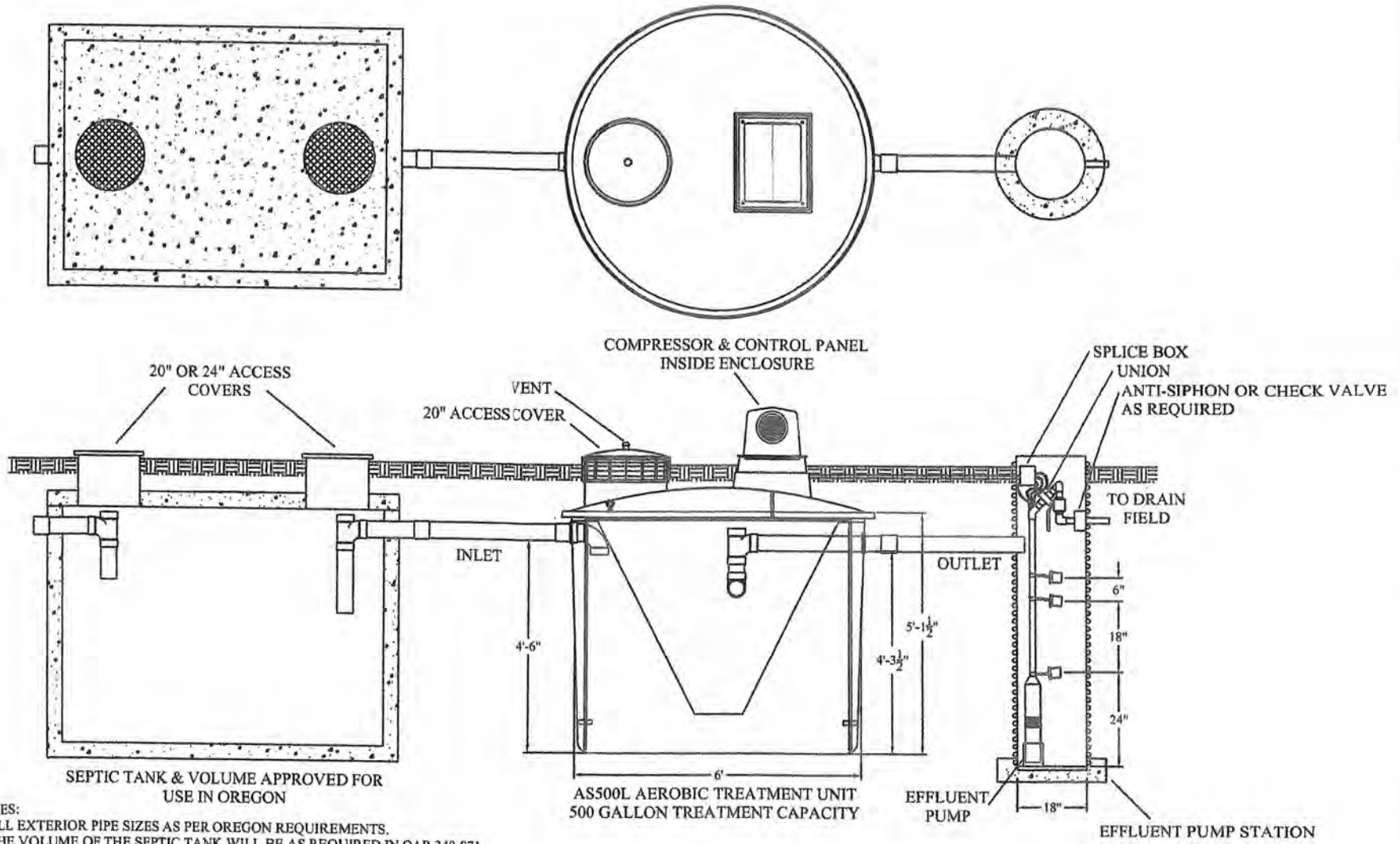

- NOTES:
1. ALL EXTERIOR PIPE SIZES AS PER OREGON REQUIREMENTS.
 2. THE VOLUME OF THE SEPTIC TANK WILL BE AS REQUIRED IN OAR 340-071.
 3. DRAWDOWN LEVEL IN 18" PUMP CHAMBER = 1.10 GAL/INCH. EIGHTEEN (18) INCHES = 19.8 GALLONS.
 4. AS AN OPTION, THE COMPRESSOR, CONTROL PANEL, AND ENCLOSURE CAN BE MOUNTED REMOTELY PROVIDED THEY ARE WITHIN 100' OF THE TREATMENT UNIT.

ECOLOGICAL TANKS, INC 2477 HWY 151 NORTH DOWNSVILLE, LA 71234	ETI 500 GPD UNIT W/ OREGON APPROVED SEPTIC TANK & HIGH HEAD PUMP STATION		
	NO PART OF THIS DOCUMENT MAY BE REPRODUCED, STORED IN ANY RETRIEVAL SYSTEM, OR TRANSMITTED IN ANY FORM OR BY ANY MEANS, ELECTRONIC, MECHANICAL, PHOTOCOPYING, RECORDING OR OTHERWISE WITHOUT THE PRIOR WRITTEN PERMISSION OF ECOLOGICAL TANKS, INC.	SCALE: NTS	DATE 10/19/09

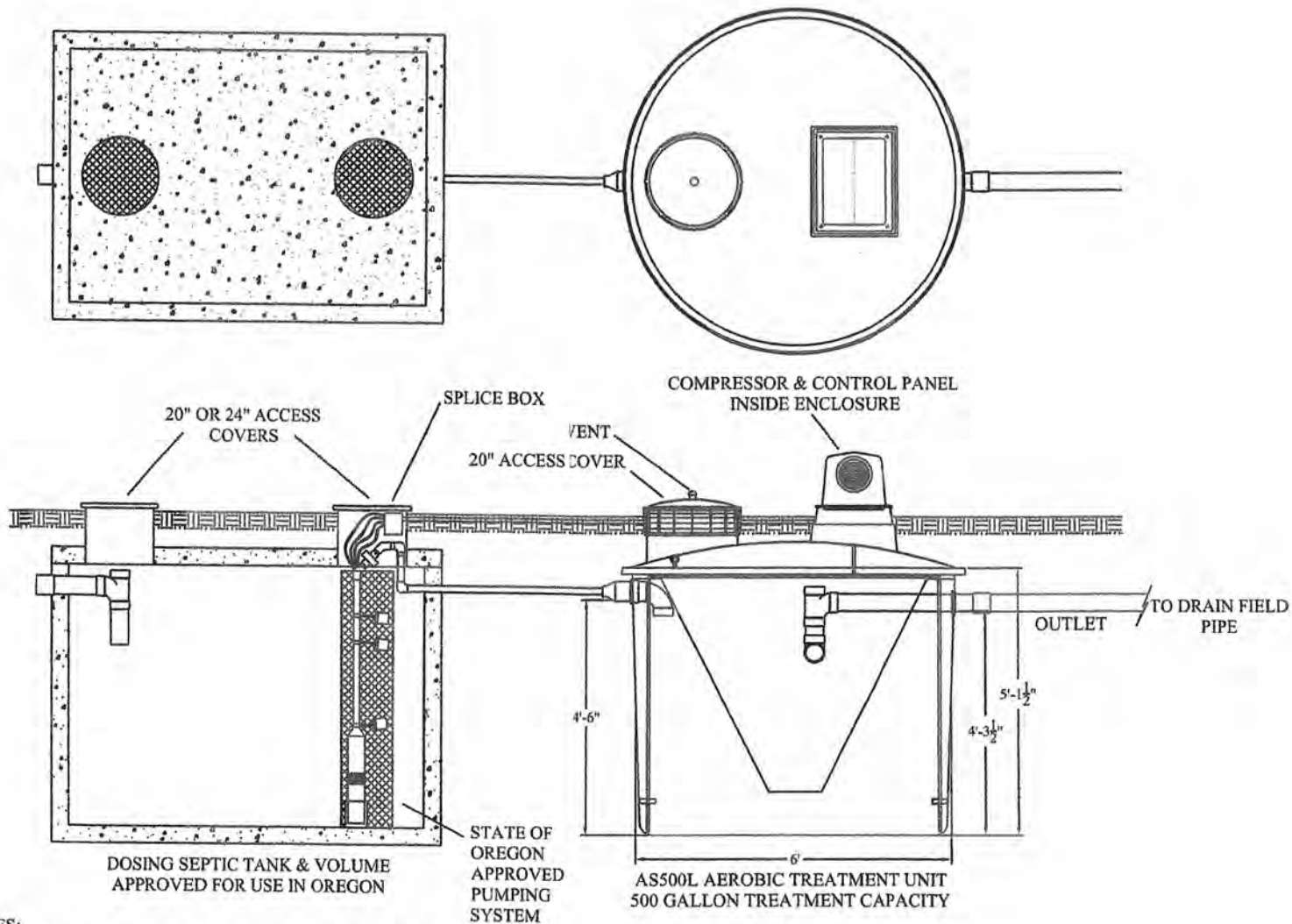

NOTES:

1. ALL EXTERIOR PIPE SIZES AS PER OREGON REQUIREMENTS.
2. THE VOLUME OF THE SEPTIC TANK WILL BE AS REQUIRED IN OAR 340071.
3. AS AN OPTION, THE COMPRESSOR, CONTROL PANEL, AND ENCLOSURE CAN BE MOUNTED REMOTELY PROVIDED THEY ARE WITHIN 100' OF THE TREATMENT UNIT.

ECOLOGICAL TANKS INC 2477 HWY 151 NORTH DOWNSVILLE, LA 71234	ETI 500 GPD UNIT W/ OREGON APPROVED DOSING SEPTIC TANK		
	NO PART OF THIS DOCUMENT MAY BE REPRODUCED, STORED IN ANY RETRIEVAL SYSTEM, OR TRANSMITTED IN ANY FORM OR BY ANY MEANS, ELECTRONIC, MECHANICAL, PHOTOCOPYING, RECORDING OR OTHERWISE WITHOUT THE PRIOR WRITTEN PERMISSION OF ECOLOGICAL TANKS, INC.	SCALE: NTS	DATE 10/19/09

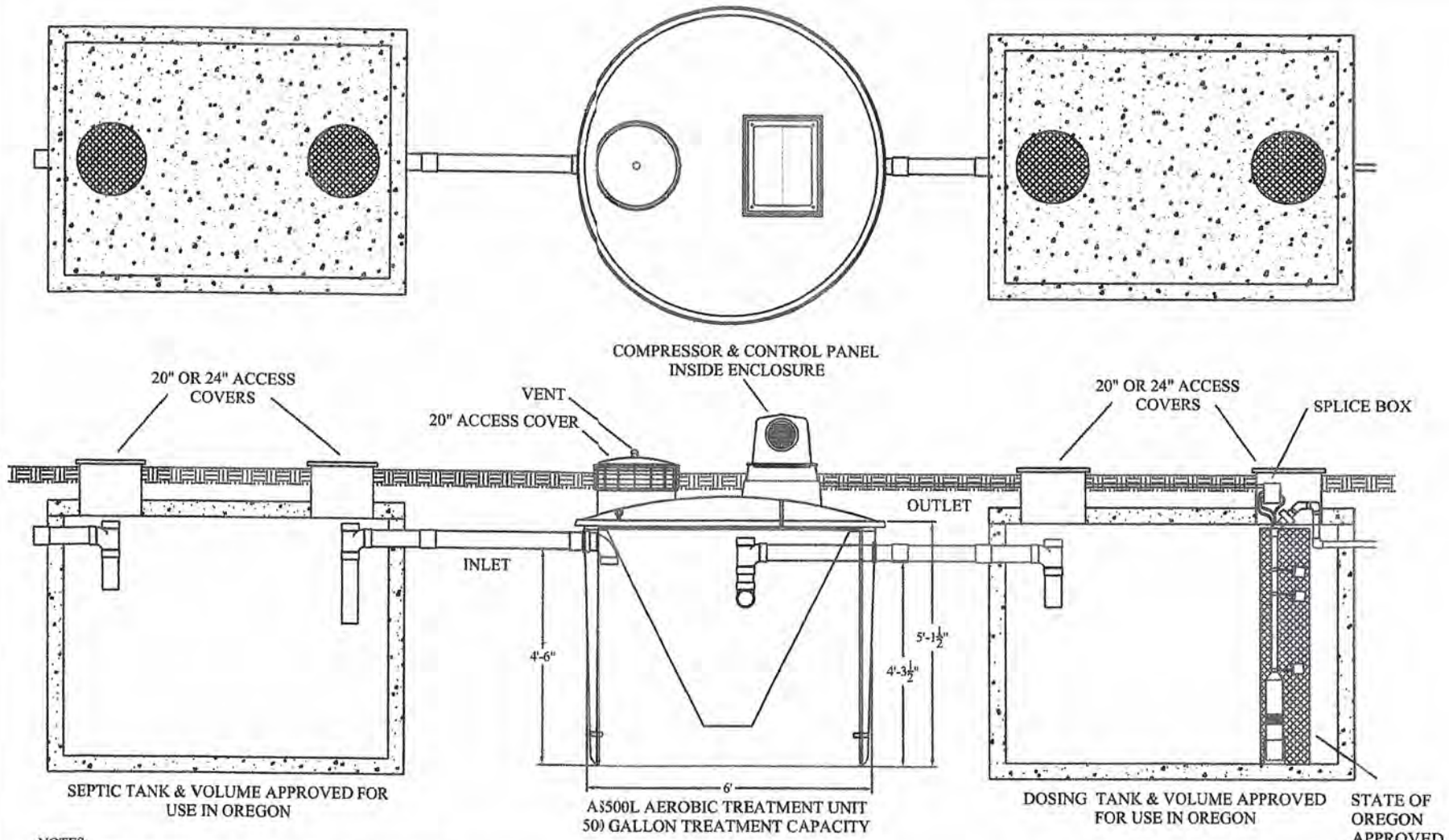

NOTES:

1. ALL EXTERIOR PIPE SIZES AS PER OREGON REQUIREMENTS.
2. THE VOLUME OF THE SEPTIC TANK WILL BE AS REQUIRED IN OAR 340-071.
3. THE VOLUME OF THE DOSING TANK WILL BE AS REQUIRED IN OAR 340-071.
4. AS AN OPTION, THE COMPRESSOR, CONTROL PANEL, AND ENCLOSURE CAN BE MOUNTED REMOTELY PROVIDED THEY ARE WITHIN 100' OF THE TREATMENT UNIT.

ECOLOGICAL TANKS, INC 2477 HWY 151 NORTH DOWNSVILLE, LA 71234	ETI 500 GPD UNIT W/ OREGON APPROVED SEPTIC TANK & DOSING TANK		
	NO PART OF THIS DOCUMENT MAY BE REPRODUCED, STORED IN ANY RETRIEVAL SYSTEM, OR TRANSMITTED IN ANY FORM OR BY ANY MEANS, ELECTRONIC, MECHANICAL, PHOTOCOPYING, RECORDING OR OTHERWISE WITHOUT THE PRIOR WRITTEN PERMISSION OF ECOLOGICAL TANKS, INC.	SCALE: NTS	DATE 10/19/09

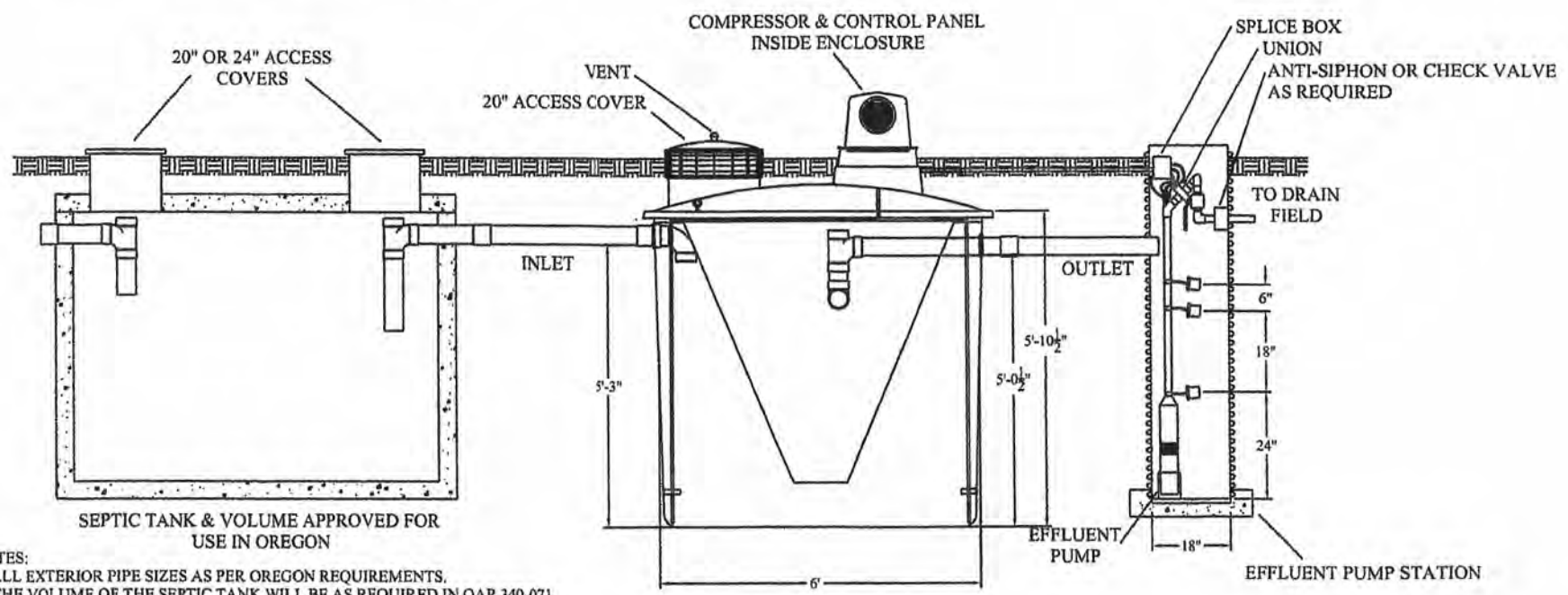
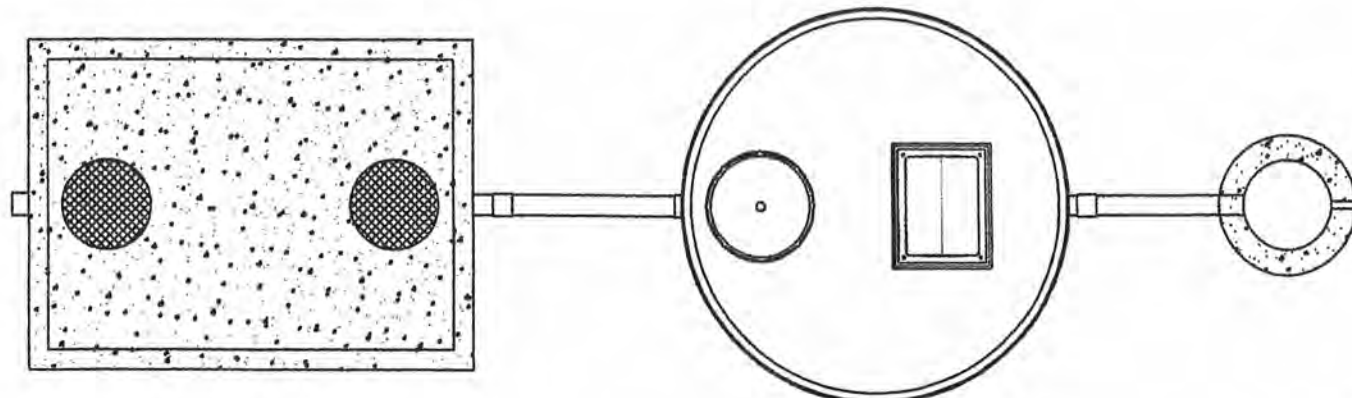

SEPTIC TANK & VOLUME APPROVED FOR USE IN OREGON

AS600L AEROBIC TREATMENT UNIT
600 GALLON TREATMENT CAPACITY

- NOTES:
1. ALL EXTERIOR PIPE SIZES AS PER OREGON REQUIREMENTS.
 2. THE VOLUME OF THE SEPTIC TANK WILL BE AS REQUIRED IN OAR 340-071.
 3. DRAWDOWN LEVEL IN 18" PUMP CHAMBER = 1.10 GAL/INCH. EIGHTEEN (18) INCHES = 19.8 GALLONS.
 4. AS AN OPTION, THE COMPRESSOR, CONTROL PANEL, AND ENCLOSURE CAN BE MOUNTED REMOTELY PROVIDED THEY ARE WITHIN 100' OF THE TREATMENT UNIT.

ECOLOGICAL TANKS, INC 2477 HWY 151 NORTH DOWNSVILLE, LA 71234	ETI 600 GPD UNIT W/ OREGON APPROVED SEPTIC TANK & HIGH HEAD PUMP STATION		
	NO PART OF THIS DOCUMENT MAY BE REPRODUCED, STORED IN ANY RETRIEVAL SYSTEM, OR TRANSMITTED IN ANY FORM OR BY ANY MEANS, ELECTRONIC, MECHANICAL, PHOTOCOPYING, RECORDING OR OTHERWISE WITHOUT THE PRIOR WRITTEN PERMISSION OF ECOLOGICAL TANKS, INC.	SCALE: NTS	DATE 10/19/09

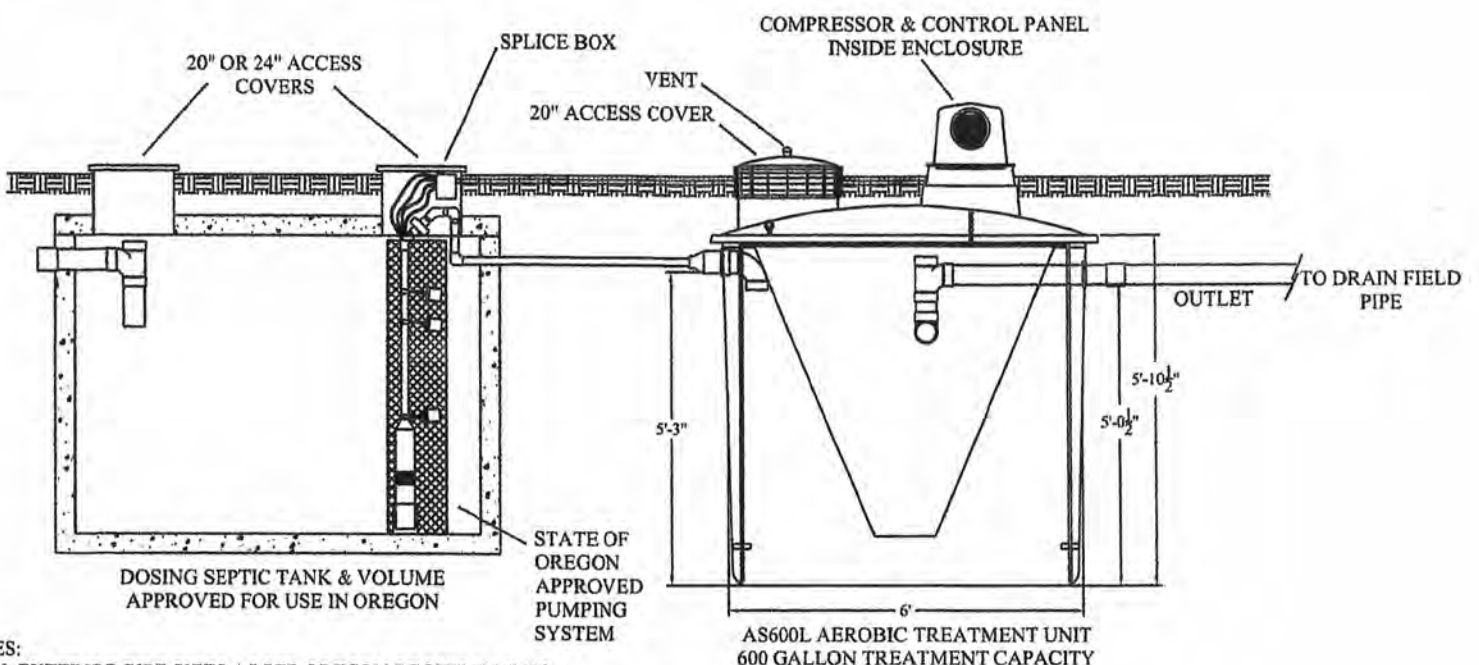
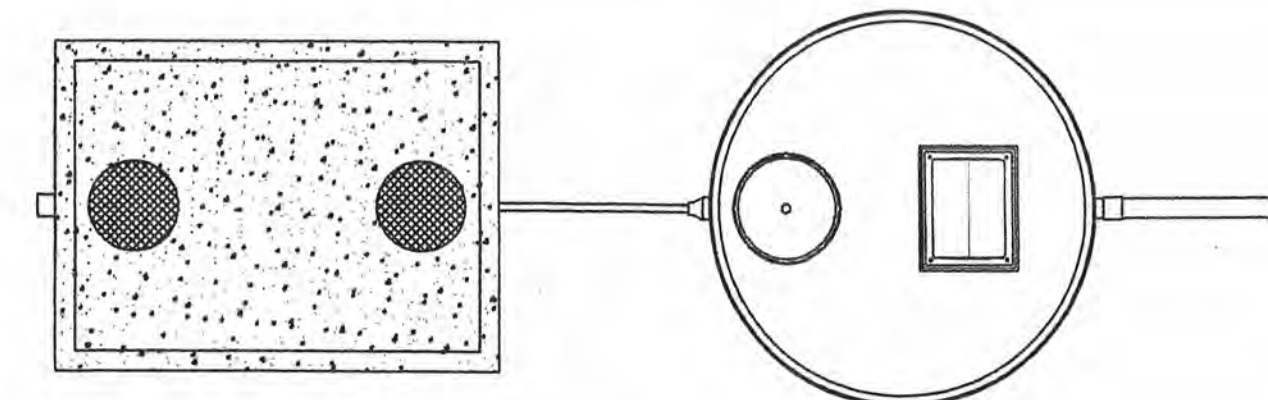

- NOTES:
1. ALL EXTERIOR PIPE SIZES AS PER OREGON REQUIREMENTS.
 2. THE VOLUME OF THE SEPTIC TANK WILL BE AS REQUIRED IN OAR 340-071.
 3. AS AN OPTION, THE COMPRESSOR, CONTROL PANEL, AND ENCLOSURE CAN BE MOUNTED REMOTELY PROVIDED THEY ARE WITHIN 100' OF THE TREATMENT UNIT.

ECOLOGICAL TANKS, INC 2477 HWY 151 NORTH DOWNSVILLE, LA 71234	ETI 600 GPD UNIT W/ OREGON APPROVED DOSING SEPTIC TANK		
	NO PART OF THIS DOCUMENT MAY BE REPRODUCED, STORED IN ANY RETRIEVAL SYSTEM, OR TRANSMITTED IN ANY FORM OR BY ANY MEANS, ELECTRONIC, MECHANICAL, PHOTOCOPYING, RECORDING OR OTHERWISE WITHOUT THE PRIOR WRITTEN PERMISSION OF ECOLOGICAL TANKS, INC.	SCALE: NTS	DATE 10/19/09

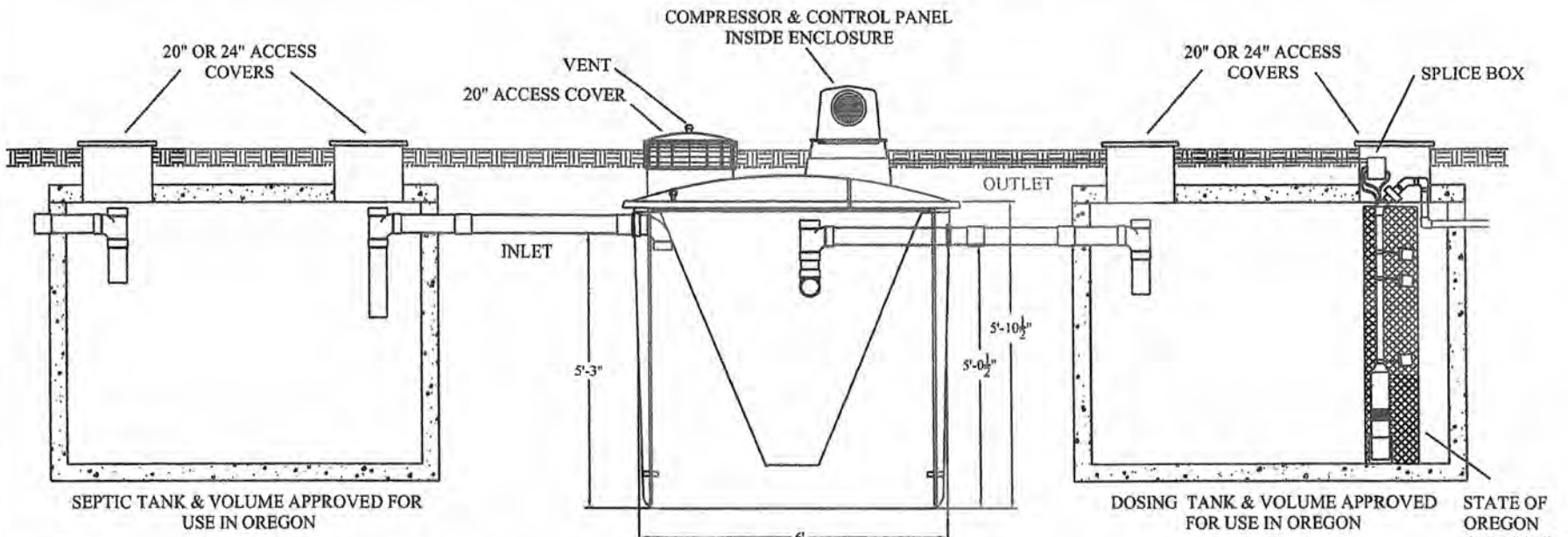
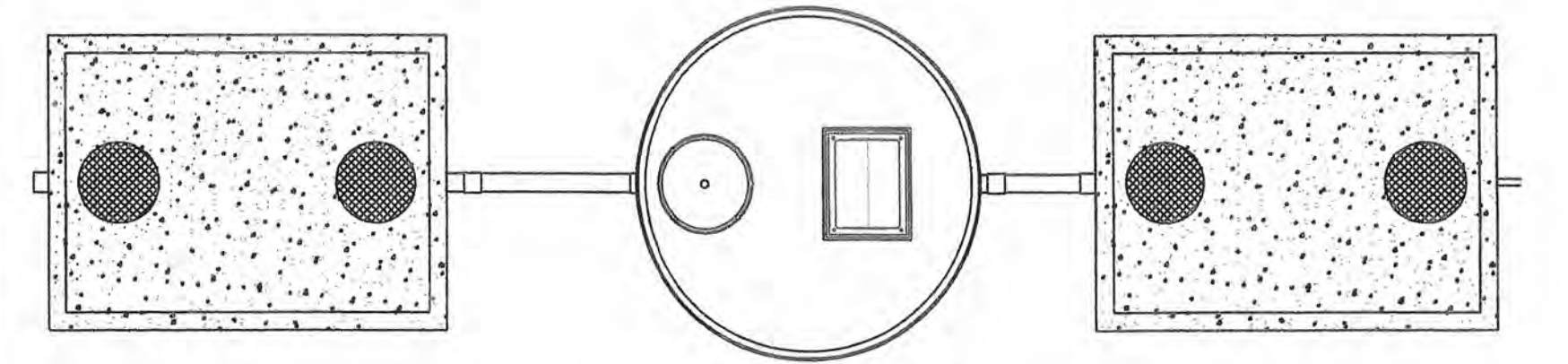

NOTES:

1. ALL EXTERIOR PIPE SIZES AS PER OREGON REQUIREMENTS.
2. THE VOLUME OF THE SEPTIC TANK WILL BE AS REQUIRED IN OAR 340-071.
3. THE VOLUME OF THE DOSING TANK WILL BE AS REQUIRED IN OAR 340-071.
4. AS AN OPTION, THE COMPRESSOR, CONTROL PANEL, AND ENCLOSURE CAN BE MOUNTED REMOTELY PROVIDED THEY ARE WITHIN 100' OF THE TREATMENT UNIT.

ECOLOGICAL TANKS, INC 2477 HWY 151 NORTH DOWNSVILLE, LA 71234	ETI 600 GPD UNIT W/ OREGON APPROVED SEPTIC TANK & DOSING TANK		
	NO PART OF THIS DOCUMENT MAY BE REPRODUCED, STORED IN ANY RETRIEVAL SYSTEM, OR TRANSMITTED IN ANY FORM OR BY ANY MEANS, ELECTRONIC, MECHANICAL, PHOTOCOPYING, RECORDING OR OTHERWISE WITHOUT THE PRIOR WRITTEN PERMISSION OF ECOLOGICAL TANKS, INC.	SCALE: NTS	DATE 10/19/09

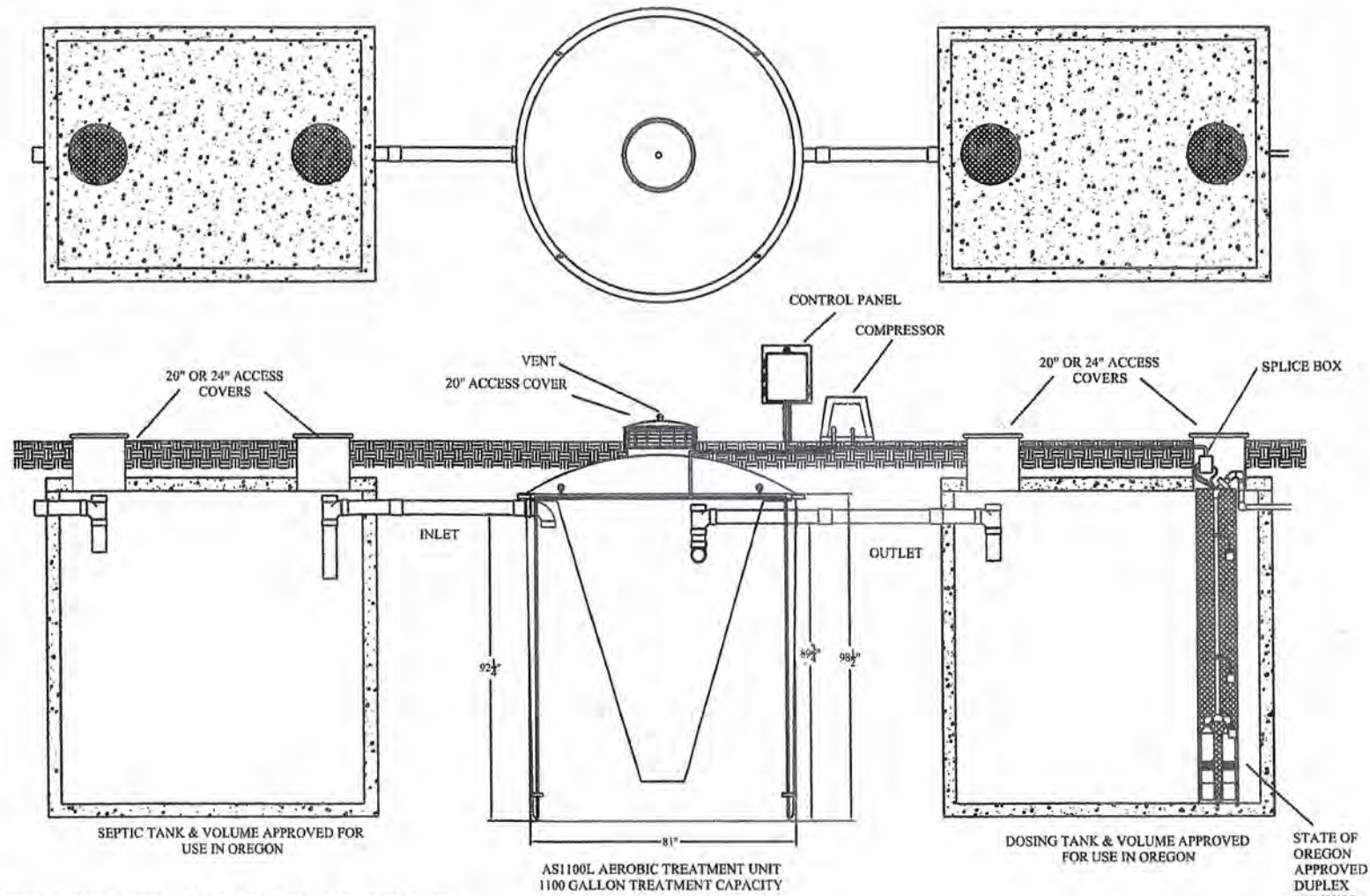

NOTES:

1. ALL EXTERIOR PIPE SIZES AS PER OREGON REQUIREMENTS.
2. THE VOLUME OF THE SEPTIC TANK WILL BE AS REQUIRED IN OAR 340-071.
3. THE VOLUME OF THE DOSING TANK WILL BE AS REQUIRED IN OAR 340-071.
4. COMPRESSOR AND CONTROL PANEL MUST BE MOUNTED WITHIN 100' OF THE TREATMENT UNIT.

ECOLOGICAL TANKS, INC 2477 HWY 151 NORTH DOWNSVILLE, LA 71234	ETI 1100 GPD UNIT W/ OREGON APPROVED SEPTIC TANK & DUPLEX HIGH HEAD PUMP STATION		
	NO PART OF THIS DOCUMENT MAY BE REPRODUCED, STORED IN ANY RETRIEVAL SYSTEM, OR TRANSMITTED IN ANY FORM OR BY ANY MEANS, ELECTRONIC, MECHANICAL, PHOTOCOPYING, RECORDING OR OTHERWISE WITHOUT THE PRIOR WRITTEN PERMISSION OF ECOLOGICAL TANKS, INC.	SCALE: NTS	DATE 10/19/09

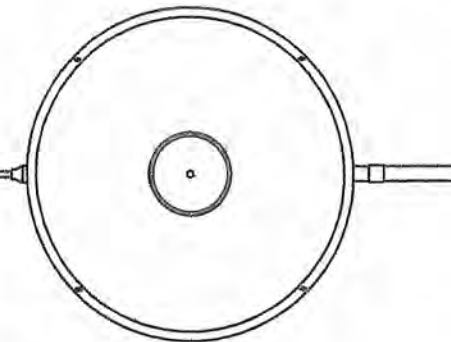
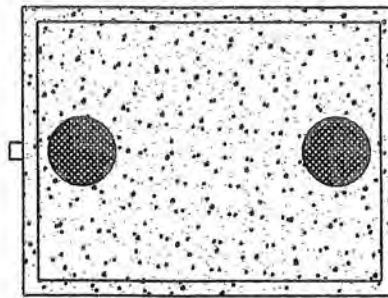
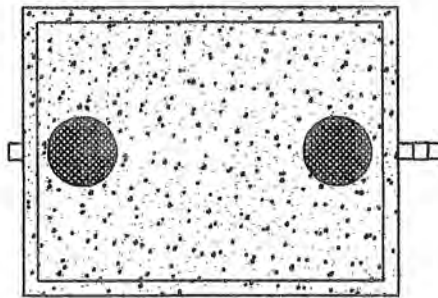

SEPTIC AND DOSING TANKS OPTIONS

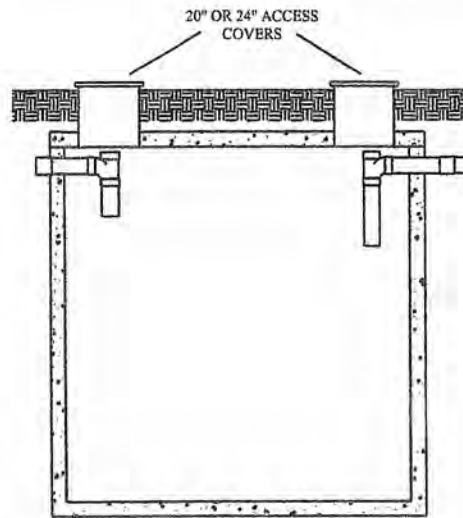

SEPTIC TANK & VOLUME APPROVED FOR USE IN OREGON

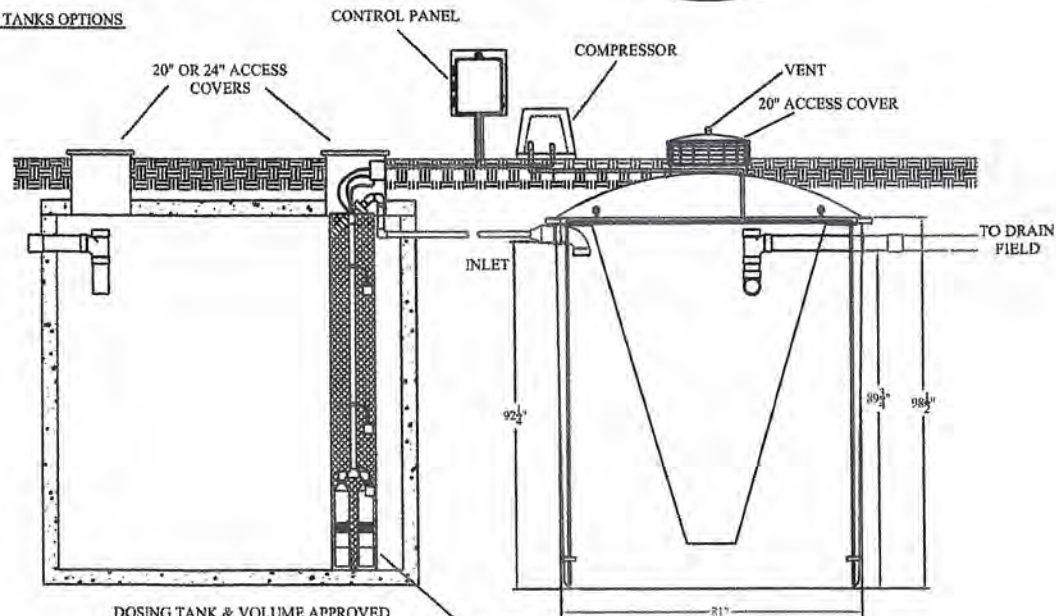

DOSING TANK & VOLUME APPROVED FOR USE IN OREGON

STATE OF OREGON APPROVED DUPLEX PUMPING SYSTEM

AS1100L AEROBIC TREATMENT UNIT
1100 GALLON TREATMENT CAPACITY

NOTES:

1. ALL EXTERIOR PIPE SIZES AS PER OREGON REQUIREMENTS.
2. THE VOLUME OF THE SEPTIC TANK WILL BE AS REQUIRED IN OAR 340-071.
3. COMPRESSOR AND CONTROL PANEL MUST BE MOUNTED WITHIN 100' OF THE TREATMENT UNIT.

ECOLOGICAL TANKS, INC 2477 HWY 151 NORTH DOWNSVILLE, LA 71234	ETI 1100 GPD UNIT W/ OREGON APPROVED PRECEDING SEPTIC & DOSING TANKS		
	NO PART OF THIS DOCUMENT MAY BE REPRODUCED, STORED IN ANY RETRIEVAL SYSTEM, OR TRANSMITTED IN ANY FORM OR BY ANY MEANS, ELECTRONIC, MECHANICAL, PHOTOCOPYING, RECORDING OR OTHERWISE WITHOUT THE PRIOR WRITTEN PERMISSION OF ECOLOGICAL TANKS, INC.	SCALE: NTS	DATE 10/19/09

III. AQUA SAFE® RECOMMENDED PLANT INSTALLATION INSTRUCTIONS

1. Inspect entire treatment plant and component parts.
2. Select location of plant site which is accessible to the home sewer discharge line, at least ten (10) feet from the home foundation, in an area that will not receive vehicular traffic. Prepare an excavation site by digging a hole at least one (1) foot larger than the treatment plant and a depth that will allow for sufficient coverage leaving approximately three (3) inches of the inspection port to extend above normal ground level. The depth of the plant will be controlled by the depth of the building sewer outlet line plus the amount of proper fall required from the building sewer outlet to the inlet invert of the plant. The prepared excavation must have a solid, level bottom that will eliminate plant settling. Additionally, the bottom of the excavated hole must be free of rocks or sharp objects. Aqua Safe® plants can be installed either on a bed of sand or undisturbed soil to provide a solid flat base.
3. Utilizing lifting lugs provided, carefully place the plant in the excavation. Insure that the inlet line slopes down toward the plant and the outlet line slopes down away from the plant. Insure that the plant is level to within one (1) inch, edge to edge. Aqua Safe® wastewater treatment plants should only be connected to properly trapped and vented plumbing systems in compliance with state and local plumbing codes.
4. Position the inlet and outlet lines and make the necessary connections. Provide clean-outs at the building sewer tie-in, any changes in direction of flow and at intervals as required by State/local codes when using four (4) inch piping. The inlet line must be inserted and glued into the inlet elbow and the discharge must be inserted and glued into the outlet coupling. Open the inspection port on top of the plant and make sure the discharge tee assembly is level and centered in the clarifier prior to connecting discharge piping. Fill the tank with water to the point of flowing discharge before backfilling. Backfill evenly around the plant, up to the bottom of the inlet and outlet piping, taking care not to damage the tank or dislodge the piping. Backfill material must be void of rocks, gravel, heavy clay or any type of material which might damage the tank.
5. If multiple tanks are installed in the same excavation, position the tanks as close together as possible. Preferably, they should be a minimum of twelve (12) inches and not more than twenty-four (24) inches apart. Provide a minimum fall of at least 1/8 – 1/4 inch per foot for the piping connecting the tanks.
6. The aerator compressor must be installed in a well ventilated, relatively clean and dry location. Install the aerator compressor on the treatment plant's tank top or at a remote location no more than one hundred (100) feet from the treatment plant. The aerator compressor is supplied complete with all discharge fittings. Install 3/4 inch schedule 40 PVC piping (supplied by others) between the aerator and treatment plant. Be careful not to allow any debris, dirt or mud in the airline during installation. Provide a minimum of twelve (12) inches ground cover over the 3/4 inch schedule 40 PVC air piping.
7. The electrical controls for the aerator compressor, visual and audible alarms for compressor failure and high water conditions, dosing pump and/or timer are contained in a weather proof enclosure. (See figures 4-22). Install the enclosure in any above ground area where the warning light is visible to the owner during the course of a normal day's activities. Install

the control box at least six (6) inches above ground level and in view of the aerator compressor housing. All electrical wiring must comply with applicable standards and shall conform to the requirements of the most current revision of the National Electrical Code. All electrical components not supplied must comply with U.L. standards. We recommend that all electrical connections be made by a licensed electrician.

8. Install electrical wiring (provided by others) to interconnect the aerator compressor and alarms to the electrical control panel. (Reference applicable field wiring diagrams.) Provide a minimum of twelve (12) inches of ground cover over underground electrical conduit and wiring.
9. If required, install the application pump in the pump tank. Most aerobic system designs that utilize a pump with the method of effluent disposal, such as low pressure dosing, should include the proper sized pump for the job. If not, once the pumping conditions are determined, selection of the right pump will be determined by two factors, pump capacity and total head needed. You must match the pump as closely to your conditions as possible to get maximum pump efficiency and dependable operation. Install and set the float switches to the appropriate level to comply with design and state requirements.
10. Run approved conduit and wiring to the pump tank from the control panel and have a qualified electrician make wiring connections. All conduit running from the pump tank to control panel must be sealed with conduit sealant to prevent moisture or gases from entering the panel.
11. The aerator compressors used on **Aqua Safe®** wastewater treatment plants run continuously. They provide relatively quiet, energy efficient operation. Once properly connected, the electrical control box is to be closed. Operate the aerator compressor by placing the on/off electrical circuit (provided by others) in the ON position.
12. Turn on aerator compressor and check all air piping and fittings for leaks. This can be accomplished by preparing a saturated solution of soap and water and applying to entire run of pipe and fittings. If a leak is detected, effect repairs.
13. Carefully backfill all underground lines and the rest of the plant's excavation in a manner which will not cause damage to the completed installation.
14. The **Aqua Safe®** plant is ready to receive incoming sewage.

IV. AQUA SAFE® PLANT START UP

Initially the **Aqua Safe®** wastewater treatment plant is filled with clean water, usually from an owner's water supply. As stated in the installation instructions, once all proper connections have been completed and it is filled with water and the aerator compressor turned on, the system is now in operation. For the treatment plant to be biologically stable, it will take from four (4) to twelve (12) weeks after first using the plant to develop a population growth of microorganisms (bacteria). It is these bacteria which make the treatment system operate.

V. OWNER MAINTENANCE, CARE AND OPERATION INSTRUCTIONS

Aqua Safe® home wastewater treatment plants have been designed and built by **Ecological Tanks, Inc.** to provide long term, reliable and cost-efficient service. Our treatment plants will operate with a minimum amount of attention.

If service is required, reference the system's DATA PLATES located on the **Aqua Safe®** control panel or aerator compressor for the plant's model number, the name, address and phone number of the local service person that can provide service. Perform the following procedure on a routine basis to insure proper plant operation:

DAILY: Check warning light and audible alarm located on the plant's control panel for air supply malfunction or in system high water indication. If an alarm on condition is observed, it is an indication of malfunction. First check the electrical circuit providing power to the system to insure the circuit is closed. Check the aerator compressor to be sure it is operating. Check for over heating, excessive vibrations and unusual noises. If aerator compressor failure is observed, call your service provider for service. After a power outage, an alarm condition may exist. Should an alarm remain on for more than thirty (30) minutes after power is restored, contact your local service provider to report the alarm.

WEEKLY: Check the treatment plant for offensive odor. If present call for service.

PERIODICALLY: Check and clean the air filter on aerator compressor. Rinse with warm water to clean if necessary. Make sure filter is dry and re-install on aerator compressor.

RECOMMENDED: Frequency of solids removal is no more often than every two (2) to five (5) years. Determination of the need for pumping can be made only by a trained service person by testing the tank contents and/or effluent. Normally, the **Aqua Safe®** wastewater treatment plant should be pumped when the settled solids are approximately sixty (60) percent of the total volume.

WARNING -Hydraulic displacement and tank flotation may occur whenever tanks are pumped. Upon completion of pumping, tank **must** be refilled with water. Additionally, care should be taken not to damage internal component parts. A certified **Aqua Safe®** service technician should oversee tank pumping.

VI. OWNER'S RESPONSIBILITY

It is the *owner's responsibility* to operate the **Aqua Safe®** wastewater treatment plant to the best of their ability. To keep maintenance to a minimum and insure high effluent quality, do not permit the following items to enter the treatment plant:

1. Strong disinfectants or bleaches, other than small amounts used in day to day house cleaning and laundries. Recommended detergents are low-sudsing, low phosphates and biodegradable. Recommended cleaning products are non-chlorine, non-toxin, non-corrosive and biodegradable. Anti-bacteria soaps should be avoided.
2. Backwash discharge from any type of water softeners.

3. Citrus products, coffee grounds, chemical wastes, paint thinners, oils or grease (such as used cooking grease), pet shampoo, pet dip disinfectant, pesticides, herbicides, automotive fluids or any other toxins.
4. Disposable diapers, tampons, sanitary napkins, large quantities of paper products, tobacco products or similar items. Home brewery waste, strong medicines and antibiotics.
5. Discharging waste material from a garbage disposal is not recommended without the use of a trash trap or pretreatment tank preceding the **Aqua Safe®** plant. Food waste represents additional loading that the aerobic treatment unit would have to digest, increasing pump out frequencies.
6. The **Aqua Safe®** wastewater treatment plant is designed for the treatment of **domestic wastewater** and nothing else should go into it. During extended period of intermittent or non-use, such as vacation time, the aerobic bacteria inside the plant will decrease due to no food in the form of incoming wastewater. The treatment plant will become biologically stable again soon after the resumption of normal loading. The aerator compressor should be left on during periods of vacation time. During extended periods of absolute non-use (3 months or longer) remove, clean and store the compressor with the compressor's inlet and outlet sealed. Additionally, cap the air line piping to prevent debris from entering the air distribution system.

The **Aqua Safe®** plant will not perform to its fullest capabilities if subject to hydraulic overloading. This condition exists whenever excessive water, above the plants designed treatment capacity, is allowed into the plant. Leaking plumbing fixtures or excessive water use may cause this condition. Hydraulic overload may also occur on wash days, when multiple loads of laundry are washed in succession.

Ecological Tanks, Inc. is not responsible for the infield operation of our plants. The proper operation of this wastewater treatment plant depends upon proper organic and hydraulic loading of the plant. We cannot control the loading of substances in our plants that may upset its biological balance. We can only provide a complete owner's manual which outlines materials that should be kept out of the treatment plant. User operation instructions must be followed or warranties are subject to invalidation.

WARNING! Ants and rodents are destructive to the mechanical and electrical equipment on wastewater treatment plants. Care should be taken to prevent infestation of ants near the plant. Damage or destruction of mechanical or electrical equipment by ants or rodents is not covered under manufacturer's warranty.

Any and all safety requirements such as the electrical wiring, blower operation or plant discharge concerning the owner, their families, friends, or guests is the sole liability of the owner (see warranty and service policy).

The electrical control panel contains a schematic for the system. However, the electrical control panel is sealed and contains no user serviceable parts. Test and alarm silence switches are located on the outside of control panel.

WARNING! Service to the electrical control panel by a non-qualified person may result in an electrical shock hazard resulting in serious injury or death. If service is required contact your local authorized installer representative or maintenance provider.

VII. INSTALLER/MAINTENANCE PROVIDER OPERATION, REPAIR AND TROUBLESHOOTING

Previous sections in this manual have covered the **Ecological Tanks, Inc. Aqua Safe®** system's functions, specifications, design, proper installation procedures, start up, owner care and operation instructions. If at this point, you are not totally familiar with the material already covered, you should read it again.

Please pay particular attention to the preceding section titled Owner's Responsibility. This section covers information critical to the plant's proper loading and function. You will find that this same information is listed in the **Ecological Tanks, Inc. Aqua Safe®** Owner's Manual. Your assurance of the owner's receipt of their manual and the explanation of the manual's contents are most critical to the plant's proper operation.

You will find, in the following sections of this manual, the Initial Service Policy. It covers information required of you as a maintenance provider in order for you to provide service in compliance with NSF/ANSI Standard 40. Additionally, most states have added to the requirements of this policy. You must know and adhere to all other regulatory agency requirements concerning mechanical plant service/maintenance standards. **Ecological Tanks, Inc. Aqua Safe®** wastewater treatment plants should be inspected every six months for proper operation. Two years of maintenance (includes a minimum of 4 inspections) is provided as a part of the systems certification requirements. Ongoing maintenance is usually part of a service agreement maintained between an owner and maintenance provider. Inspections include any necessary adjustment of electrical controls and servicing of the component parts and also include a visual check of hoses, wires, leads, contacts, cleaning of filters, removal of organic particles, and testing of alarms to ensure proper function. An effluent quality inspection consists of a visual check for color, turbidity, scum overflow, and an examination for odors. A mixed liquor inspection may be necessary if the plant is not performing properly or if offensive odors are present. If any improper operation is observed which cannot be corrected at that time, the user shall be notified in writing immediately. This notification shall advise the owner of the problem, if it is covered by the warranty, if not, the cost related to correcting the problem and estimated date for correction of said problem.

VII-1. EXAMPLE OF A ROUTINE MAINTENANCE SERVICE CALL

First check the system's control panel for any alarm or failure indication. Check the panel to insure proper incoming power by testing the incoming power supply. If you know power is incoming into the control panel, check the circuit feeding the control panel. Next, check the aerator simply to insure that it is running and then go directly to the treatment plant for an effluent quality inspection as outlined in the service policy section. At this point pay particular attention to odors you notice at the plant (or pump tank if applicable). You may notice an earthy smell which is nothing more than carbon dioxide gas emitted by the aerobic bacteria in the plant. There may be a sweet smell or no smell at all and that's good. Should you experience an obnoxious odor, something is wrong. Access the aeration mixing compartment, if necessary, to examine the mixed liquid and air diffusion system.

Return to the control panel, check for proper functions as outlined in this manual. Also, reference the troubleshooting guidelines covered on pages 31-32. Before servicing the control panel and

alarm system, disconnect power to the control panel.

Clean or replace the aerator compressor air filter at this time. If you experienced an offensive odor when at the plant and heard little or no bubbling, finding a clogged or extremely dirty air filter may be the problem. Turn on the aerator at this time and check for any air leak between the aerator and the 3/4" schedule 40 PVC piping. If a leak is detected, effect repair. If a leak is not detected, the following steps should be taken.

Remove the aerator from the rubber hose connection and install a low pressure gauge between the PVC piping and aerator. Turn on the aerator and note the pressure. If the line pressure is below 1.5 P.S.I., then there is a leak between the aerator and the air distribution system in the treatment plant or the aerator's diaphragm is ruptured. (See the aerator compressor repair section.) Determine the cause and effect repairs at this time. If a pressure above 3.5 P.S.I. is noted, the air system piping diffuser assembly is blocked. You can clear the air distribution system's blockage by charging the air distribution piping with compressed air (no more than 80 P.S.I.). Re-check the line pressure after any maintenance procedure to the plant's air distribution piping to insure the correct pressure range. The normal line pressure should be between 1.83 P.S.I. and 2.85 P.S.I.

V11-2. SCHEDULE OF ROUTINE SERVICE AND MAINTENANCE EVENTS

Routine Inspections.....	6 months (or as required by state/local agency)
Air Filters Cleaning/Replacement.....	6 months
Compressor Diaphragm Replacement.....	2-3 years
Compressor Replacement	6-8 years
Removal of Residuals from ATU/pre-tank.....	2-5 years
Replacement of UV Bulbs (if applicable).....	2 years

VII-3. AERATOR COMPRESSOR REPAIR

Linear aerator compressors (See Page 25) are used on all models of the **Aqua Safe®** wastewater treatment plants. They provide quiet energy efficient operation. Additionally, rotary vane compressors (See Page 26) are provided upon request, in-lieu of linear aerator compressors. All aerator compressors on all models of the **Aqua Safe®** aerobic wastewater treatment plants run continuously.

Periodic aerator compressor maintenance will help you to operate the aerator in the optimum condition and insure longer aerator life. Air filters should be cleaned every six months and replaced as necessary. **Ecological Tanks, Inc.** recommends that the air filters be replaced once a year. The plant's air distribution piping pressure should be measured at least once per year. Aerator compressors must be operated at the recommended output pressure range which is between 1.5 and 3.5 P.S.I. Aerator life is shortened if operations outside of the specified pressure ranges occur.

Ecological Tanks, Inc. recommends the diaphragm blocks on linear aerator compressors be replaced every three years. We also recommend that the vanes be replaced every four years on

rotary vane aerator compressors. Referring to Pages 25-26, note the following text for diaphragm block and vane replacement procedures:

LINEAR COMPRESSOR HEAD AND DIAPHRAGM REPLACEMENT

1. Remove linear blower from electrical power and move to a well lit spot.
2. Remove the top plastic cover and discard the filter element.
3. Turn the blower over and remove (4) screws using either a #2 Phillips screwdriver or a 10 mm socket.
4. Remove the top housing and internal filter.
5. On all linear compressors, remove the drive cover by taking out (4) Phillips screws.
6. Carefully, inspect the shuttle assembly and electric coils. Any damage to these components will require replacing the linear blower.
7. Using a pair of pliers, slide the hose clamp down the discharge hose and remove the hose from the head assembly.
8. Remove the head assembly by taking out (4) Phillips screws and separating the head from the diaphragm casing by prying the two pieces apart at the notch in the head.
9. Remove the diaphragm lock nut and washer. Slide the diaphragm block off the shuttle stud. **NOTE:** On the Gast units only, the diaphragm ring will also be removed during this operation.
10. Install the new diaphragm and casing by sliding the diaphragm over the shuttle stud and centering the diaphragm casing in the housing. Install the washer. Place (1) small drop of Loctite thread lock on the end of the stud and install the nut. Tighten to 14 in. lbs.
11. Install a new head assembly by locating the head over the diaphragm casing and tightening the (4) Phillips screws.
12. Slide the discharge hose back on the head and replace the clamp.
13. Follow procedure #7 thru #12 for the opposite side.
14. Install the internal filter and replace the blower cover.
15. Install the (4) Phillips screws, replace the filter element and replace the filter cover.
16. Return the unit to service.

ROTARY COMPRESSOR VANE REPLACEMENT

1. Unplug compressor, disconnect piping and move to a suitable work area.
2. Remove (5) 7/16" hex bolts and remove front cover and gasket (if present).
3. Remove vanes while paying particular attention to the proper orientation of vanes in the rotor.
4. Using low pressure compressed air, blow out any dust or carbon particles from rotor and cylinder. (Always use safety glasses when performing this procedure.)
5. Inspect the rotor, cylinder and front cover for any signs of metal contact or cracks.
6. Rotate the rotor by hand to be sure the motor and bearings are free.
7. Install a new set of (4) vanes into the rotor slots.
NOTE: the chamfered edge of the vanes goes against the cylinder bore.
8. With the motor resting on its base, rotate the rotor by hand to insure the vanes move freely.
9. Install the front cover and torque the (5) hex bolts to 10ft.-lbs.
10. Replace the felt washers on the inlet filter.
11. Prior to installing compressor back on system, plug the unit in and let it run for a couple of minutes. Unit should have a constant hum and should not exhibit any excess vibration.
12. Unplug the unit and listen for the coast down of the compressor. The compressor should coast down to a dead stop. If the unit stops immediately, go back to step #2 and check for any metal-to-metal rubbing.
13. Install unit back on plant.

HIBLOW HP80

REPAIR PARTS

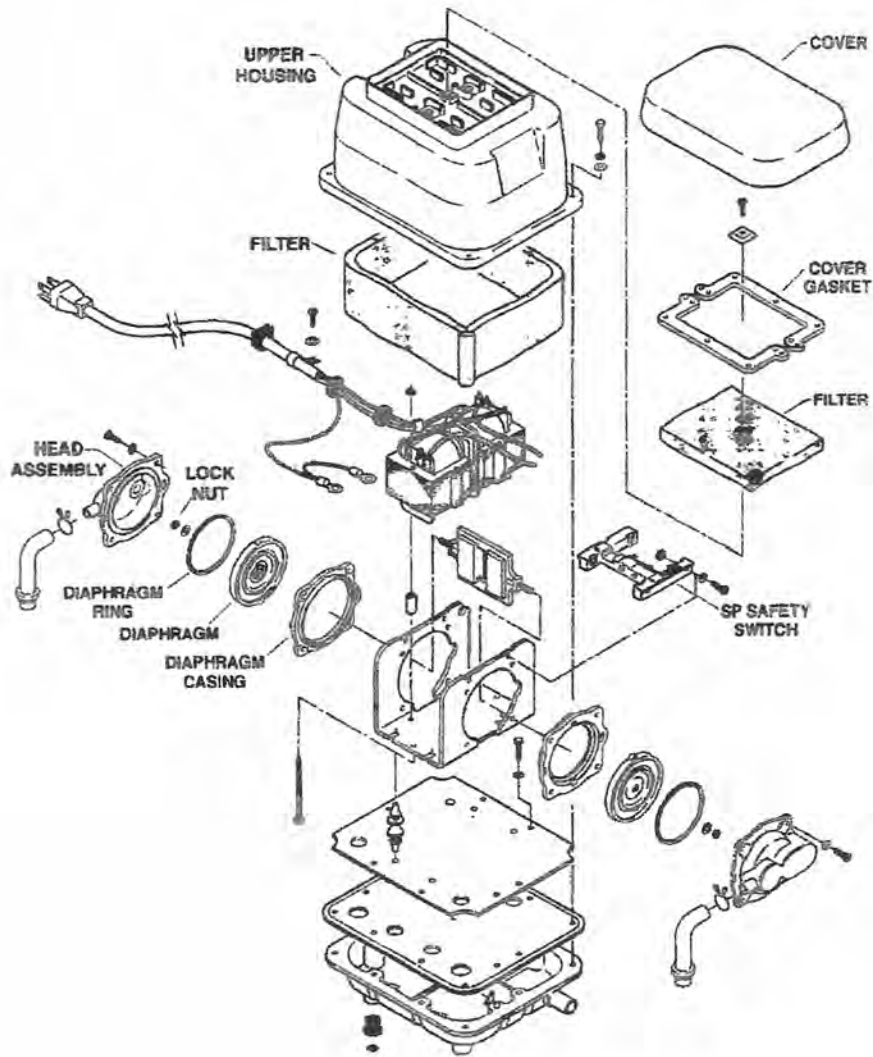

FIGURE 6

EXPLODED PRODUCT VIEW, PARTS & ORDERING INFORMATION

1	BODY	1	AK504	AK500
2*	VANE	4	AH850A	AH850A
3	SHROUD	1	AK502B	AK502B
4	END PLATE	1	AK501	AK501
5*	GASKET	1	AK521	AK521
6	MUFFLER BOX	1	AK519	AK519
7*	O-RING	2	AK473	AK473
8*	FELT	2	AK524	AK524
9	END CAP	2	AK510	AK510
10	END CAP FILTER ASSEMBLY	2	AK526	AK526
11	FILTER / MUFFLER	1	B343B	B343B
12	FOOT SUPPORT KIT	1	AC136	AC136
13	FELT SUPPORT	1	B347	B347
14*	FELT FILTER	2	B344A	B344A
15	SCREEN CAP	1	AJ571	AJ571
16	ROTOR	1	AH775B	AH775B
17	TOLERANCE RING	1	AF105	AF105
	SERVICE KIT	1	K882	K882

* Denotes parts included in the Service Kit. Parts listed are for stock models.

** No Service Kit available, order parts separately. For specific OEM models, please consult the factory. When corresponding or ordering parts, please give complete model and serial numbers.

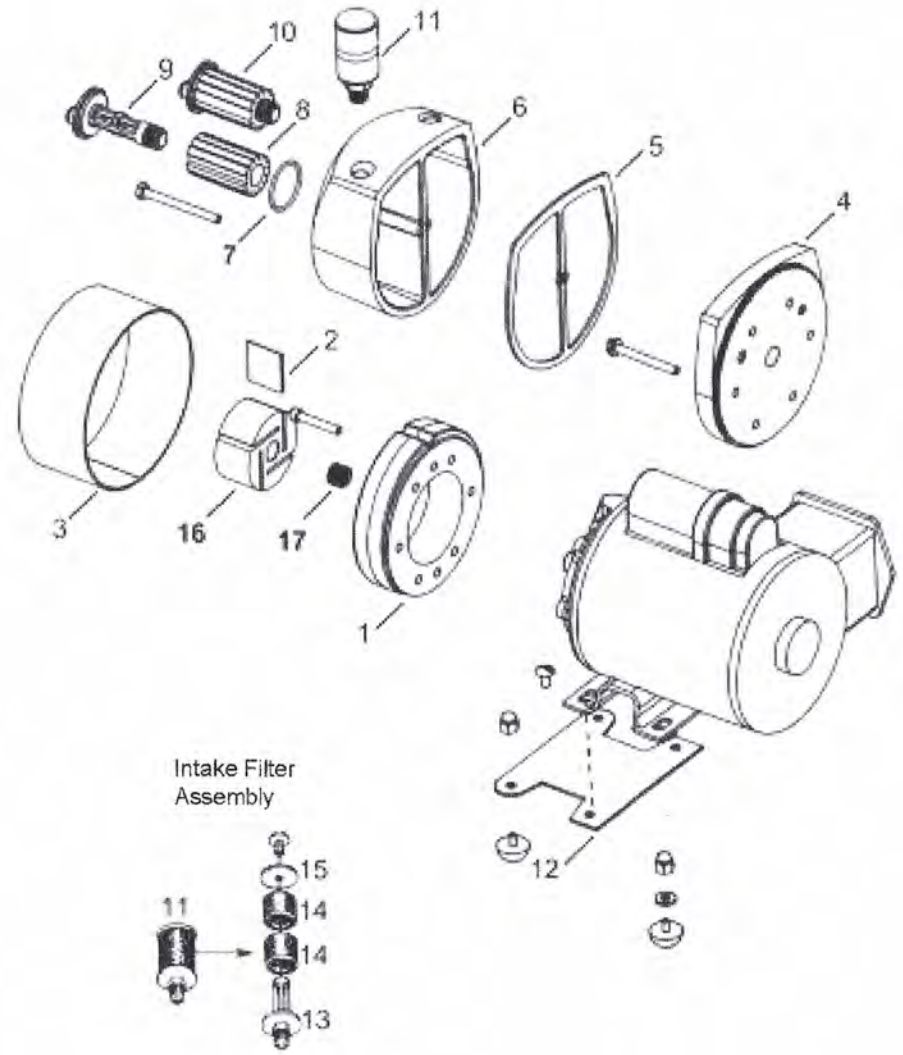

GAST AT03 ROTARY VANE

FIGURE 7

AERATOR SPECIFICATIONS
for Aqua Safe "L" Series Treatment Systems

Aqua Safe® aerators for use with all models:

All aerators listed are 115 Volt, 60 Hertz and Single Phase

Models AS500L, AS500L-EZ, AS500L-C

GAST Model AT03 - Rotary – 3.0 amps / 120 watts / 4.0 CFM open flow

Hiblow Model HP80- Linear- 1.8 amps/105 watts / 4.2 CFM open flow

Model AS600L, AS600L-EZ, AS600L-C

HiBlow Model HP100- Linear- 1.55 amps / 90 watts / 5.2 CFM open flow

GAST Model AT05 - Rotary – 3.0 amps / 120 watts / 4.8 CFM open flow

Model AS1100L, AS1100L-EZ, AS1100L-C

GAST Model 0823 - Rotary - 8.6 amps / 560 watts / 8.0 CFM open flow

HiBlow Model HP200- Linear- 3.4 amps / 125 watts / 10.5 CFM open flow

VII-4. METHODS FOR EVALUATION OF EFFLUENT AND MIXED LIQUOR

Problem	Possible Cause	Corrective Action
Offensive odor from plant and effluent	Aerator or air piping defective, leaking or clogged	Check aerator, air piping and alarm system
Murky to gray mixed liquor with semi-clear effluent having a sour odor	Plant starving due to infrequent loading, hydraulic overloading, or oversized pretreatment tanks resulting in totally anaerobic, or low BOD influent	Confer with homeowner regarding loading. Remember, it may take 4 to 12 weeks for a new plant to start.
Black colored, mixed liquor and effluent having a totally septic odor void of dissolved oxygen, having an approximate pH between 6.5 and 8	Plant receiving little or no aeration due to defect in aerator or air piping	Check aerator, air piping and alarm system
Black colored, mixed liquor and black-tinted effluent having an offensive odor and acidic pH	Plant loaded or dosed with influent that prohibits growth of aerobic bacteria	Confer with homeowner regarding loading. Adjust pH to between 6.5 and 8.5; dose system with approved bacterial additives to help restart micro-bacterial growth or pump tank for fresh start
Brown mixed liquor with a viscous, brown foam having an obnoxious odor in the mixing zone with semi-clear effluent high in TSS	Developed population of filamentous micro-organisms in aeration zone due to low food to micro-organisms ratios, the presence of toxins or improper pH level.	Confer with homeowner regarding proper plant loading. Adjust pH to between 6.5 and 8.5. Dose plants mixing zone with approved bacterial additive
Chocolate-brown mixed liquor with clear effluent	Plant working properly with effluent pH between 6.5	None required
quality having only a slight earthy smell in mixing zone	and 8.5 and D.O. level between 1 and 5.5 mg/L	

VIII. EFFLUENT SAMPLING REQUIREMENTS

When properly loaded, operated and maintained, the **Aqua Safe®** wastewater treatment plant should provide an effluent quality consistent with the E.P.A. secondary treatment guideline parameters. The expected final discharge from the plant should provide an effluent quality of:

less than	25 mg/l.	CBOD ₅
less than	30 mg/l/	TSS
pH of	6 to 9	

Test results conducted by Baylor University's Department of Environmental Studies in accordance with NSF/ANSI Standard 40 requirements showed the **Aqua Safe®** wastewater treatment plant to have a 30 day effluent average of:

2.37	mg/l.	CBOD ₅
2.11	mg/l.	TSS

Ecological Tanks, Inc. recommends that ALL final effluent samples be taken in the effluent discharge line or the effluent pump discharge line at a sampling port designed for that purpose. We recommend allowing the effluent to flow through the discharge pipe for a minimum of two (2) minutes before taking the sample.

VIII-1. SAMPLING AND TESTING PROCEDURES FOR BOD₅ OR TSS

1. Effluent grab samples to be analyzed for BOD₅ or TSS should be done by a certified testing lab. The certified lab should provide you with information concerning proper sample collection to include volume, storage and labeling of sample. For a fee, most labs will provide the glass or plastic bottles to be used.
2. Always follow your testing lab's instructions concerning proper sample labeling, collection and storage.

For the referenced sample collection in this section, the testing lab's minimum instructions should be:

A. Label each sample to include:

1. Name and physical address of owner
2. Time and date of collection
3. Desired test
4. Name of person collecting sample

- B. Collect samples only in clean glass or polyethylene bottle or jar at a volume specified by the lab.

- C. Store samples in a cooler to near freezing temperature as soon as samples are collected.
 - D. Deliver samples for analysis within six (6) hours of collection.
3. Activate the application pump and collect the sample from the sample port in the pump tank or from fresh flow in the effluent discharge line after the disinfection device.

VIII-2. TESTING FOR SOLIDS REMOVAL

1. As previously noted in other sections of this manual, a sample of mix liquor should be taken from the aerobic plant's aeration mixing compartment to determine the suspended solids content of the aeration compartment.
2. Using a clear glass or plastic graduated cylinder, let the sample settle for thirty (30) minutes. If the settled amount of suspended solids is greater than sixty percent (60%) after thirty (30) minutes, the aerobic tank should be pumped out.

VIII-3. OTHER TESTING

1. To determine the composition of the aerobic plant's influent wastewater strength, collect a grab sample from the flow between the pre-treatment tank and aerobic treatment plant.
2. Samples should be taken from fresh flow directly out of the pre-tank's outlet baffle. Refer to information covered earlier in this section for proper handling of a sample from the job site to a certified testing lab.
3. Influent grab samples, at a minimum, should be analyzed for BOD₅, TSS, COD and pH. A pH test can be done on the job site by following the simple instructions with your pH test kit. However, BOD₅, TSS and COD tests should be conducted by a certified lab.
4. The need to determine the concentration of other influent contaminants may arise. Collect, handle and test the sample in the same manner as outline in this section.
5. Constituent concentrations in typical residential wastewater per Table 3-7 as listed in the USEPA Onsite Wastewater Treatment Systems manual are:

BOD ₅	155 to 286 mg/l.
TSS	155 to 330 mg/l.
COD	500 to 660 mg/l.
pH	6 to 9

IX. ORDERING OF SYSTEMS, PARTS AND MANUALS

Ecological Tanks, Inc. Aqua Safe® maintains ample supplies of parts to meet the needs of new sales, replacement parts, warranty parts and manuals. Please feel free to call us or your local distributor so we can help meet these needs.

Troubleshooting Guidelines for Control Panels

Note: Power must be on to test horn and alarm light.

Alarm Horn

Pressing the alarm test switch, turning the compressor circuit breaker "OFF", or activating the alarm float should turn on the alarm horn. If the horn does not sound, replace with horn of same type.

Alarm Light

Pressing the alarm test switch, activating the alarm float, or turning the compressor circuit breaker "OFF" should turn on the alarm light. If the light does not activate, replace bulb with the same type.

Circuit Breakers

Check the circuit breaker for proper resistance reading using the following procedures:

1. With power "OFF", isolate the circuit breaker by disconnecting the load side wires.
2. Place the ohmmeter leads across the corresponding line and load terminals.
3. With the ohmmeter on the RX1 scale and the breaker in the "OFF" position, the reading should be infinity (very high resistance). With the breaker in the "ON" position, the reading should be nearly zero ohms (very low resistance). If the readings are not as stated, replace the circuit breaker with one of the same ratings.

Note: Readings may vary slightly depending on the accuracy of the measuring device.

Air Switch

If lamp and horn are on and pump in pump tank is performing normal:

1. Disconnect air line at fitting at bottom of control panel and feel for air coming out of line.
2. If air supply is normal, then air switch is malfunctioning. Replace switch through manufacturer's stock.

24 Hour Clock Timer

Clock not running

1. Check for input power to the control panel.
2. Check all terminals for secure connections.
3. Check breaker to see that is in "ON" position.
4. If no circuit fault is evident, replace clock. Clock may be obtained through manufacturer's immediate stock.

Pump Test Switch

Switch not working

1. Turn power to "OFF". Disconnect both leads to the switch.
2. Connect one test lead from an ohmmeter set on RX1 to one post on the pump test switch.
3. Connect the other lead from the same ohmmeter to the other post of the pump test switch.

4. Pull on the toggle of the pump test switch.

Note: The meter needle should deflect across the entire scale. If the needle does not deflect or reads open, replace the switch with one of the same type and rating.

Test/Mute Switch

Switch not working

1. Turn Off power. Disconnect all leads from the "TEST/MUTE" switch.
2. Connect one lead from an ohmmeter set on RX1 to the center post on circuit 1.
3. Connect the other lead from the ohmmeter to the lower or second post in circuit 1.
 - A. With the toggle in the "OFF" or "MUTE" position there should be no deflection of the needle on the ohmmeter.
 - B. With the toggle in the center position, the needle on the ohmmeter should deflect across the entire scale.
 - C. By pulling the toggle into the "TEST" position, the needle on the ohmmeter should stay in the full deflection position.
4. Disconnect both leads from the switch.
5. Connect one lead from an ohmmeter set to RX1 to the center post of circuit 2 on the "TEST/MUTE" switch.
6. Connect the other lead from the same ohmmeter to the lower or second post of circuit 2.
 - D. With the toggle on the "OFF" or "MUTE" position there should be no deflection of the needle on the ohmmeter.
 - A. With the toggle in the center or normal position there should be no deflection of the needle on the ohmmeter.
 - B. By pulling the toggle into the "TEST" position, the needle on the ohmmeter should deflect across the entire scale.

Note: If results other than those just described are attained, replace the "TEST/MUTE" switch.

Plant Controls

Check the floats throughout their entire range of operation. Clean, adjust or replace damaged floats. The float resistance can be measured to determine if the float is operating correctly or is defective by using the following procedures:

1. Isolate the float by disconnecting one or both of the float leads from the float terminals.
2. Place one ohmmeter lead on one of the float wires and the other ohmmeter lead on the other float wire.
3. Set the ohmmeter dial to read ohms and place on the RX1 scale. With the float in the "OFF" position, the scale should read infinity (very high resistance). Replace the float if you do not get this reading. With the float in the "ON" position the scale should read nearly zero (very low resistance). Replace float if you do not get this reading.

Note: Readings may vary slightly depending on the length of wire and accuracy of the measuring device.

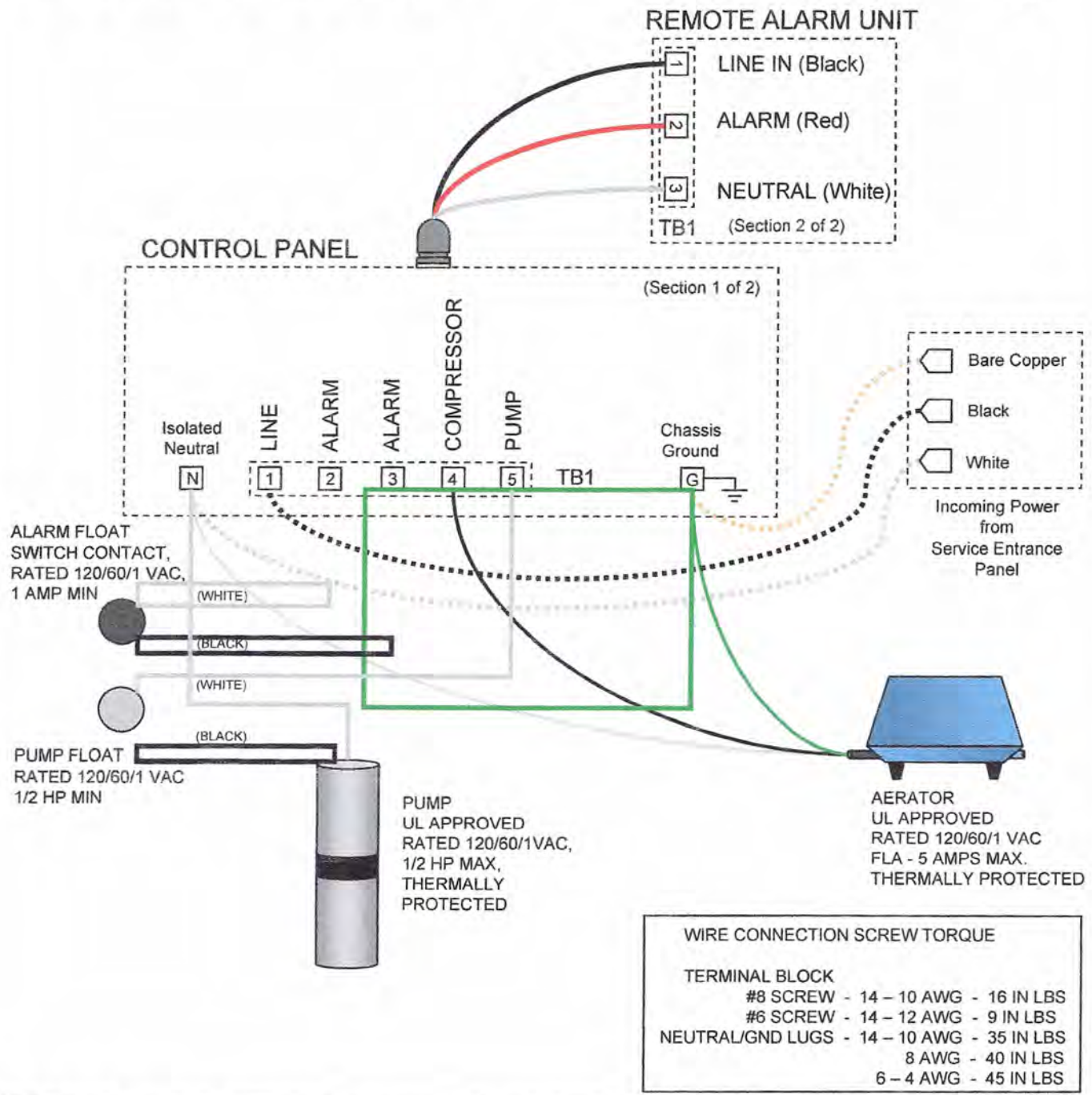

- Notes for field installed components:
1. Main Disconnect, Branch Circuit Protection, wiring and external components to be provided by installer.
 2. Field wiring - #14 - #10 AWG, 60°C min, use copper conductors only.
 3. Field installed conduit fittings must be rated for use with Type 4X Enclosure.
 4. **Conduit openings must be sealed around wiring with an electrical grade (non-corrosive) sealant to prevent potentially harmful vapors from entering the control panel.**

FIGURE 8

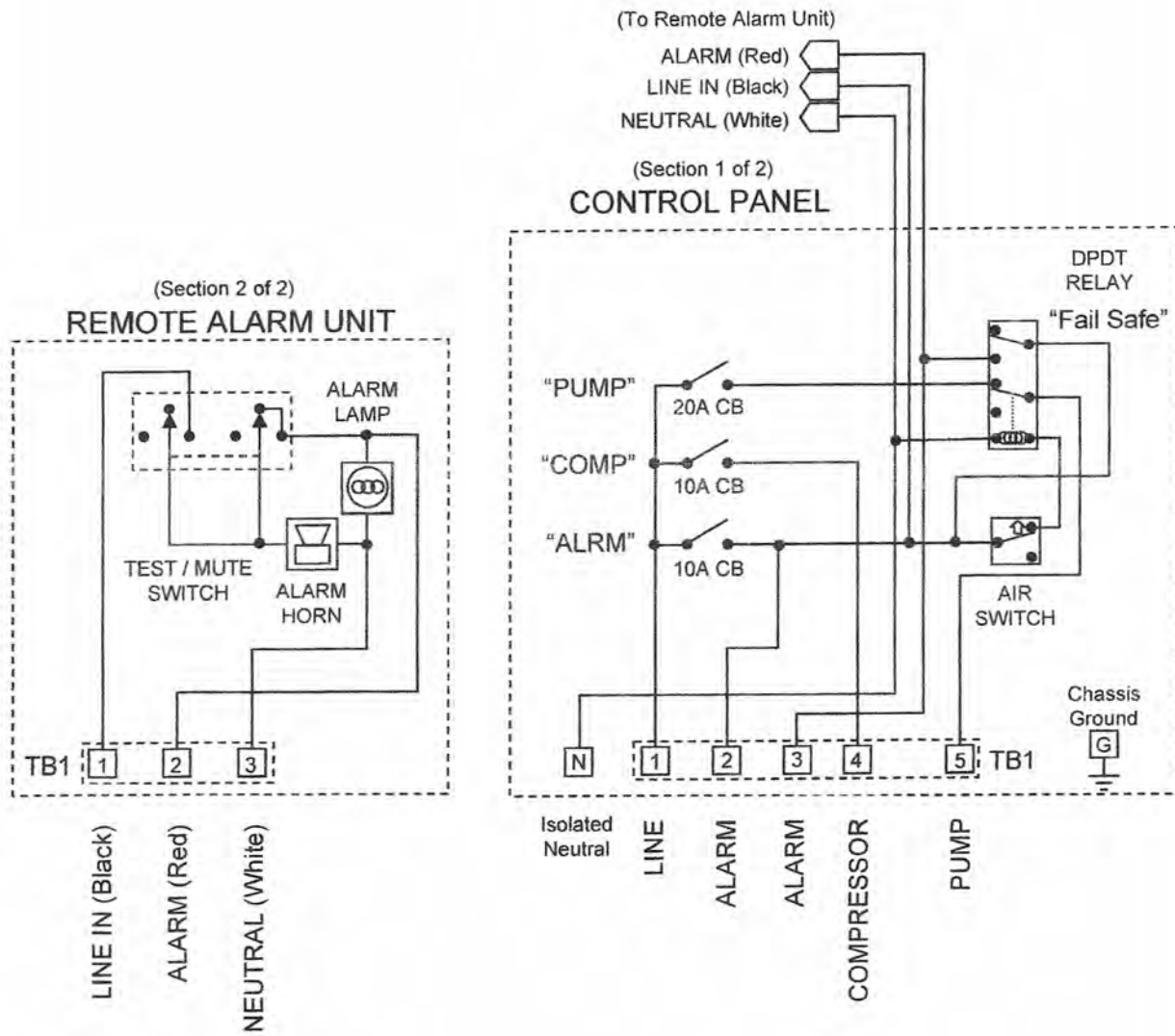
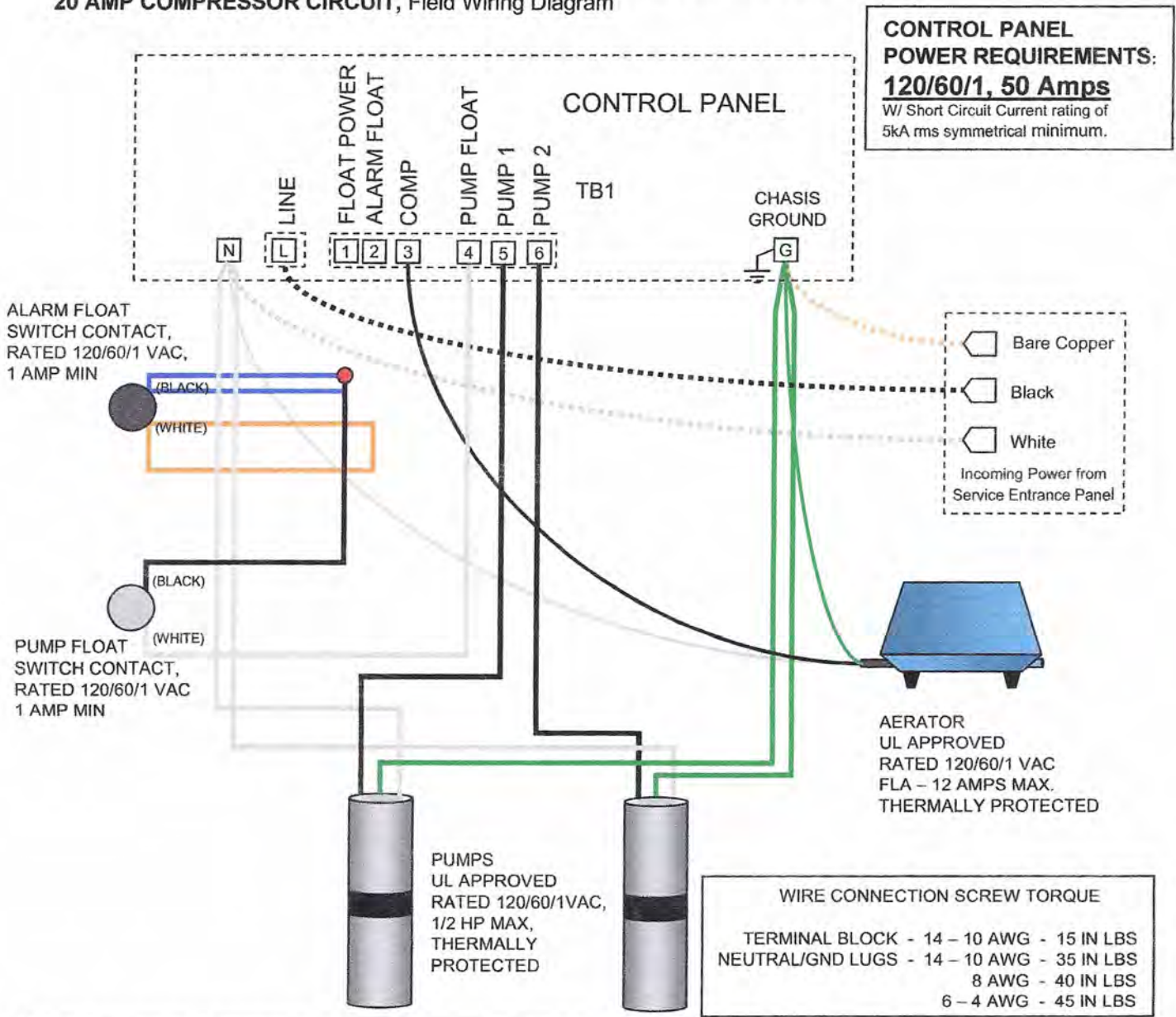

FIGURE 9

MODEL DFS1D - 120 VAC DEMAND DOSE DUPLEX, HOURMETER & EVENT COUNTER ON EACH PUMP, FAILSAFE PUMP LOCKOUT ON COMPRESSOR FAIL, 20 AMP COMPRESSOR CIRCUIT, Field Wiring Diagram



Notes for field installed components:

1. Main Disconnect, Branch Circuit Protection, wiring and external components to be provided by installer.
2. Field wiring - #12 - #8 AWG, 60°C min, use copper conductors only.
3. Field installed conduit fittings must be rated for use with Type 4X Enclosure.
 If used, metal conduit fittings must provide means to bond conduit to ground terminal.
4. Torque Terminal Block, Neutral and Ground screws to 15 - 20 in-lbs.
5. **Conduit openings must be sealed around wiring with an electrical grade (non-corrosive) sealant to prevent potentially harmful vapors from entering the control panel.**

FIGURE 10

MODEL DFS1D - 120 VAC DEMAND DOSE DUPLEX, HOURMETER & EVENT COUNTER ON EACH PUMP, FAILSAFE PUMP LOCKOUT ON COMPRESSOR FAIL, 20 AMP COMPRESSOR CIRCUIT, Schematic

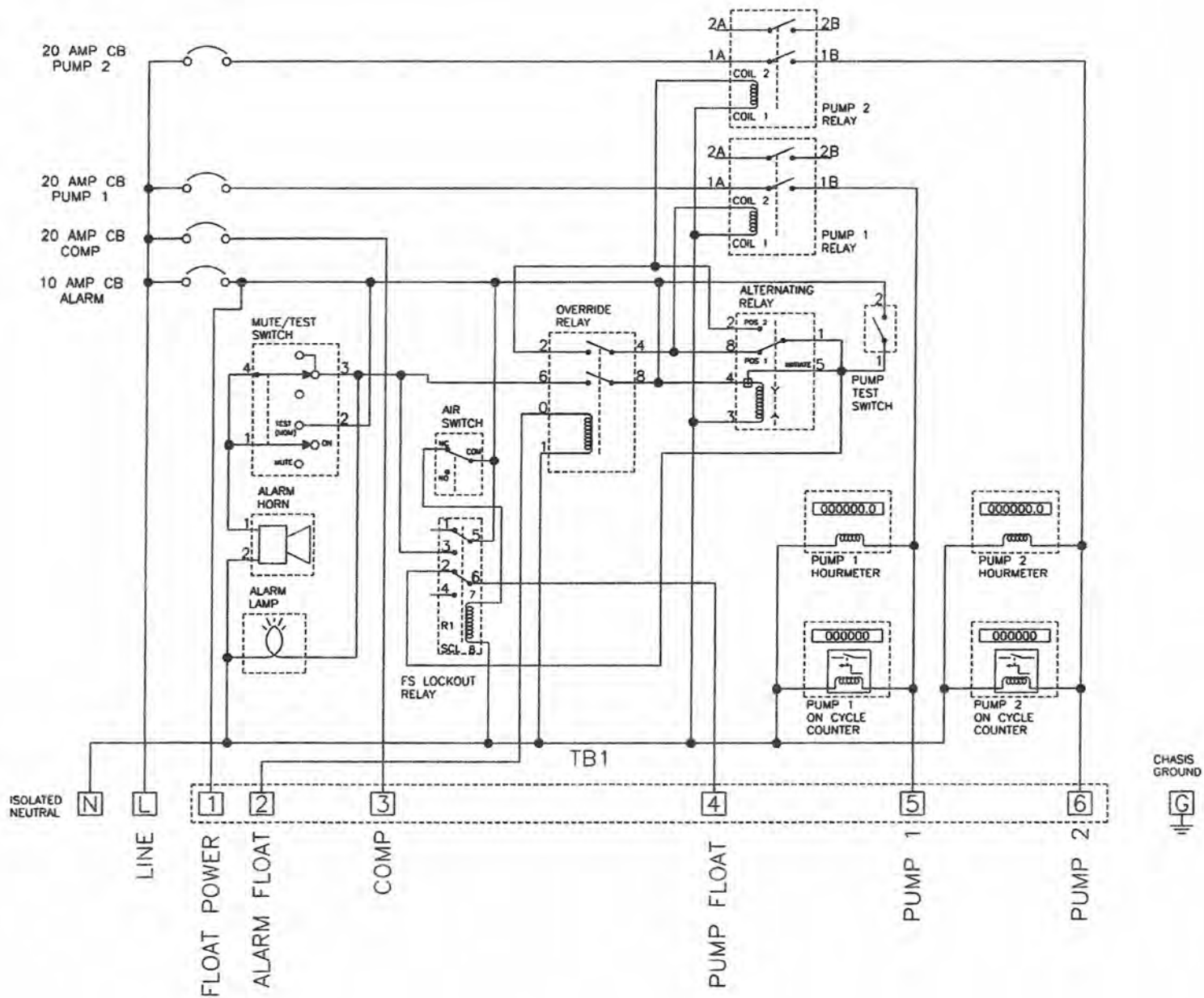

FIGURE 11

LIMITED WARRANTY

Ecological Tanks, Inc., Aqua Safe® (hereinafter identified as manufacturer) warrants each **Aqua Safe®** wastewater treatment plant to be free from defects in workmanship and materials from the date of installation by an authorized dealer/installer for the following periods: Manufacturer warrants system aerator for a limited, prorated five (5) year period as follows: First two (2) years - 100%; 2nd to 3rd year - 75%; 3rd to 4th year 50%; and 4th to 5 year period 25% of manufacturers list price. Third, fourth and fifth year limited, prorated portion of this warranty applies only if system owner carries a continuous maintenance policy provided by an authorized dealer/installer and **proof** is provided with return. Manufacturer warrants fiberglass tanks, for a limited period of five (5) years to be free from defects in material and workmanship. Electrical controls, float switches and application pumps are warranted two (2) years. Concrete tanks are limited to two (2) years from date of installation. When properly installed and **registered** with the manufacturer, the manufacturer's sole obligation under this **limited warranty** is as follows:

To repair or exchange any components, F.O.B. factory, that in the manufacturer's judgment is defective, provided that said component part has been paid for and is returned through an authorized dealer, prepaid. The warrantee must specify the nature of the defect in writing to the manufacturer. The **limited warranty** makes no provision for any informal dispute settlement agreement.

The **limited warranty** does not cover any **Aqua Safe®** wastewater treatment plant that has not been properly installed, damaged due to altered or improper wiring or overload protection, flooded by any external means, disassembled by any unauthorized person, filled with anything other than normal household wastewater or damaged by an act of nature. The **limited warranty** does not cover damages or defects caused by ants, insects or rodents to any component part of the **Aqua Safe®** wastewater treatment plant.

No warranty is made as to the field performance of any system. The **limited warranty** applies only to the **Aqua Safe®** wastewater treatment plant itself and does not include any of the purchaser's plumbing, drainage and/or disposal system, house wiring or the installation of the **Aqua Safe®** treatment plant.

The manufacturer reserves the right to replace any component part covered under this **limited warranty** with a component part, which in manufacturer's judgment is equivalent to the part being replaced. The manufacturer claims no responsibility for any delays or damages caused by defective components or materials which cause losses incurred by interruption of service or for repairs or replacements of component parts covered by the **limited warranty**.

MANUFACTURER'S WARRANTY REGISTRATION CERTIFICATE

It is the **authorized dealer/installer's responsibility** to fill out the registration certificate and mail it **within 30 days** of installation to the address below. The owner/purchaser should verify that this is done to insure proper registration for warranty purposes.

**ECOLOGICAL TANKS, INC.
2247 HIGHWAY 151 NORTH, DOWNSVILLE, LA 71234
OFFICE: 318-644-0397 FAX: 318-644-7257**

PLEASE PRINT

AQUA SAFE® PURCHASER'S RECORD

Serial# _____ **Model#** _____ **Installation Date** _____
Installer's Name _____
Mailing Address _____
_____ **Phone** _____

AQUA SAFE® INSTALLER'S RECORD

Serial# _____ **Model#** _____ **Installation Date** _____
Owner's Name _____
Physical Address/City _____
_____ **Phone** _____

**AQUA SAFE® REGISTRATION CERTIFICATE
(Must be returned to manufacturer)**

Serial# _____ **Model#** _____ **Installation Date** _____
Owner's Name _____
Physical Address/City _____
_____ **Phone** _____
Dealer's Name _____
Mailing Address _____
_____ **Phone** _____
Installer's Name _____
Mailing Address _____
_____ **Phone** _____

