

norweco® **HYDRO-KINETIC**®

WASTEWATER TREATMENT SYSTEM TAKING THE ORDER

Each Hydro-Kinetic wastewater treatment system is sold complete including: delivery and installation of the tank; installation and start-up of the air pump, recirculation pump and control center; and two-year limited warranty with prescheduled service inspections as required by local regulations. It is important that the Hydro-Kinetic order be taken and recorded carefully to insure that all federal, state and local regulations are met. A clear outline of responsibilities when the order is taken will simplify installation of the system and establish a sound working relationship with your customer and local health department.

INSTALLATION PROCEDURE

Installation of the Hydro-Kinetic system normally occurs in two phases. First, the precast concrete tankage is delivered and installed at the contractor's convenience. The electrical control center and underground electrical service cables are also installed at this time. Only when the system is ready for start-up are the air pump and recirculation pump delivered and installed. When the Hydro-Kinetic installer has completed equipment installation, he should also start-up and test the entire system and familiarize the owner with its operation. This installation procedure will assure efficient use of the contractor's and installer's time and protect equipment from possible damage or unauthorized start-up.

CONTACT THE LOCAL HEALTH DEPARTMENT

The contractor must contact the local health department prior to installation of the Hydro-Kinetic system and apply for an installation permit. The local distributor will have drawings, specifications and performance data for the system on file with the health department. Normally, the contractor will not be required to supply this information to receive the installation permit. The health department may request a drawing showing the proposed method of effluent disposal and location of the Hydro-Kinetic system in relation to the building, property lines and potable water supply. The health department may wish to inspect the site and proposed point of discharge, take soil samples or run percolation tests before issuing an installation permit. The contractor must find out if an inspection of the Hydro-Kinetic tank and sewer line will be required before backfilling is allowed.

DELIVERY TRUCK ACCESSIBILITY

Inform the contractor of the dimensions and weight of the delivery truck. The excavation must be accessible without interference from trees, shrubbery, power lines or other obstacles. Earth from the excavation must be piled outside the working area needed to operate the truck. Remind the contractor that extra charges will apply if the excavation is not complete and readily accessible.

EXCAVATION SIZE AND DEPTH

When installing a Hydro-Kinetic system, first check the length, width and depth of the excavation. If installing a Model 600 FEU system, insure the excavation is long enough to allow at least 2' between the treatment tank and the Hydro-Kinetic Bio-Film Reactor for installation of the interconnect plumbing and backfill between the tanks. The distributor must provide a 4" Schedule 40 PVC pipe cut 6" longer than the distance between the tanks for the interconnect plumbing. Insert the interconnect pipe into the inlet of the Hydro-Kinetic Bio-Film Reactor prior to tank placement. This allows the interconnect pipe to be backed straight out, and solvent welded into the cast-in outlet coupling of the clarification chamber when the tank is set. The excavation should have sufficient overdig to allow for a minimum of 6" clearance around the entire perimeter of the system. Additional overdig will be required on deep installations or where unstable soil conditions exist. Always maintain safe working conditions during the installation procedure.

The excavation depth must be calculated using several factors. First, note the elevation of the sewer line as it leaves the building. From this sewer line elevation, subtract $\frac{1}{8}$ " per foot from the building to the system location. Next, subtract the dimension from the outside bottom of the tank to the inlet invert of the system. This dimension is 5' 0" when installing a standard Hydro-Kinetic concrete tank and 4' 0" when installing a low profile Hydro-Kinetic concrete tank. Fall through the Model 600 system is 4" from inlet to outlet invert. In the Model 600 FEU that includes the Hydro-Kinetic Bio-Film Reactor, fall through the system is 5" from inlet to outlet invert. Therefore, the outlet line from the system must be installed either 4" or 5" lower than the point where the inlet sewer line joins the system.

TANK LEVELING PAD

To insure that the tank bottom will be bearing the weight evenly, all tanks should be set on a four inch thick pad of gravel, sand or fine crushed stone. The pad should be installed and leveled by the contractor before delivery and setting of any tank takes place. The tank pad must be leveled to within $\frac{1}{4}$ " from side to side and end to end.

TAKING THE ORDER (Cont.)

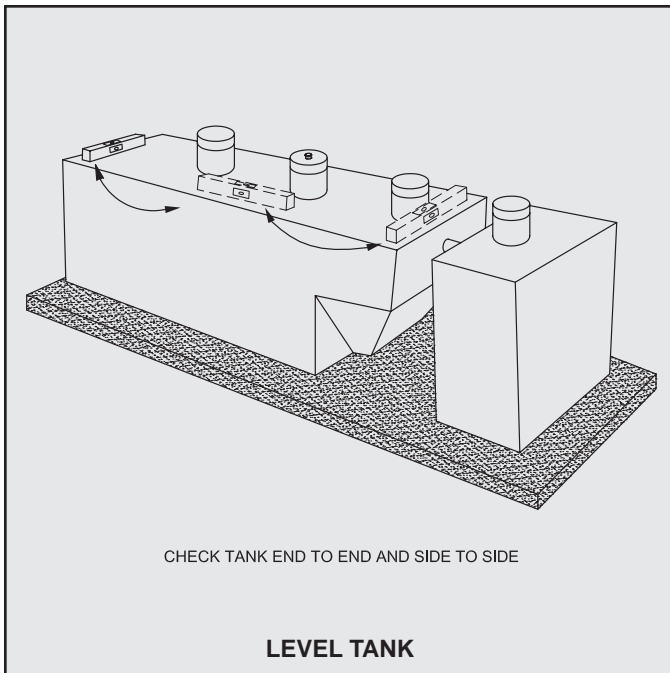

BACKFILLING THE TANKAGE

CAUTION: Do not allow dirt, debris or other material to enter the Hydro-Kinetic system during installation or backfilling. The Hydro-Kinetic system must be backfilled immediately after installation. Any fine, granular jobsite material or backfill may be used. Large clumps of earth, rocks or debris should never be used to backfill around the system. The slanted endwall beneath the clarifier must be backfilled with particular care. Be sure it is completely backfilled so that future settling will not cause a low spot in the finished lawn or place an undue strain on the outlet line.

FILLING THE SYSTEM WITH WATER

The Hydro-Kinetic system should be filled with clean water immediately after installation. Water should be added as the tank is being backfilled to equalize internal and external tank pressure. Fresh water is preferred but water from a nearby pond may be used if it is free of silt and other debris. Never use a septic tank pumping service to fill the Hydro-Kinetic system. If this is done, large amounts of biologically untreatable materials may be deposited in the system and they could interfere with system operation and performance.

INLET SEWER LINES

Only domestic wastewater must be allowed to enter the Hydro-Kinetic system. It is not intended to handle flows from roofing down spouts, basement footer drains, sump pump piping or garage and basement floor drains. If the sanitary sewer system must be used for disposal of these liquids, it must be connected downstream of the system. Water softener backwash will affect system performance and must not flow into the Hydro-Kinetic system.

EFFLUENT DISPOSAL LINE

Due to the high level of treatment provided by the Hydro-Kinetic system, its effluent may be discharged in a number of acceptable fashions. There must be a ground water relief point installed in the discharge line that provides an outlet no higher in elevation than the outlet invert of the Hydro-Kinetic tank. This will prevent tank contents from backing up when the normal discharge point is temporarily under water or the effluent disposal field is saturated.

ELECTRICAL POWER SUPPLY

A dedicated 115 volt AC single-phase, 10 amp (minimum) 60 Hertz circuit must be provided in the main electrical service panel for the Hydro-Kinetic system.

FINISH GRADING AND LANDSCAPING

A precast concrete aeration chamber riser with vented cover is provided for the air pump and extends 19" above the top of the tank. The top of each cover must project a minimum of 6" above finished grade. Individual precast concrete riser castings may be added in 12" increments when necessary. Determine if riser sections will be needed before tank installation is scheduled.

A precast concrete riser casting with non-vented cover is provided for the anoxic and clarification chambers. The top of each cover must project a minimum of 6" above finished grade. Individual precast riser castings may be added in 12" increments. Determine if riser sections will be needed before tank installation is scheduled.

PRETREATMENT CHAMBER ACCESS

Normally, the removable cover in the tank top is all that will be needed for pretreatment chamber access. On deeper installations, the removable cover in the tank top must always be developed to within twelve inches of grade. Some owners and regulatory officials require that access to the pretreatment chamber must be at finished grade. This should be determined when the order is taken so the appropriate riser castings and covers may be delivered.

SCHEDULING TANK DELIVERY

When all points have been fully explained, find out the customer's preferred installation date and make preliminary scheduling with your dispatcher. Take the customer's telephone number to confirm tank delivery.

MANUFACTURED BY

norweco[®]

Engineering the future of water
and wastewater treatment.

**NORWECO, INC.
NORWALK, OHIO
U.S.A. 44857
www.norweco.com**

norweco® **HYDRO-KINETIC**®

WASTEWATER TREATMENT SYSTEM

TANK DELIVERY AND SETTING

To insure that all work proceeds safely and efficiently, check these items prior to delivery of the Hydro-Kinetic tankage.

- ✓ Does the driver have complete and accurate directions to the installation?
- ✓ Does the driver have the Hydro-Kinetic installer's tool kit?
- ✓ Is all equipment in good condition?
- ✓ Are the appropriate number of riser castings, extension riser castings and vented and non-vented access covers included?
- ✓ Is sufficient leveling material available for the bottom of excavation?
- ✓ Is there an adequate supply of sealing material for the tank and all plumbing connections?
- ✓ Does the truck have the proper pick-up bar and cable (or chain)?
- ✓ Is the proper Service Pro control center available for delivery with the tank?
- ✓ Is there sufficient underground electrical cable to reach from the control center location to the tank?
- ✓ Is there sufficient air line to reach from the air pump location to the aeration riser if air pump is to be mounted remotely?
- ✓ Is the intermediate recirculation assembly included with the delivery?

PLEASE NOTE: *The Hydro-Kinetic tank is constructed of monolithic castings and, if possible, the joints should be sealed at your plant before setting. This will minimize tank loading, unloading and setting time at the site. The castings may be set individually and sealed at the site if necessary. These instructions are written as if the castings will be installed separately and sealed at the site. However, the tank should be assembled and sealed in your plant if your tank handling and delivery equipment will allow it. Otherwise, proceed with tank setting as outlined herein.*

BEFORE YOU START

Installation procedures, equipment and personnel should always comply with applicable safety regulations as well as all federal, state and local codes. The Hydro-Kinetic system must be installed according to these instructions to insure safe, reliable and efficient operation. The system must be installed by an authorized representative of Norweco.

The Hydro-Kinetic system components include:

1. Service Pro Model 801P Control Center
2. Model A100 Air Pump
3. Alarm Float
4. Flow Equalization Device
5. Primary Recirculation Assembly
6. Model SD103 Recirculation Pump
7. Intermediate Recirculation Assembly
8. Diffuser
9. Mixing Bar
10. Mixing Bar Drop Pipe Assembly
11. Diffuser Drop Pipe Assembly
12. Primary Air Assembly
13. Hydro-Kinetic Bio-Film Reactor Elements

PRE-DELIVERY TANK PREPARATION

The Hydro-Kinetic tank equipment package and Bio-Film Reactor Elements should be installed before the system is delivered to the installation site. This allows for more consistent working conditions inside of the tank. Some components of the tank equipment package will be cast-in during the manufacturing process, and other components will be installed after the casting process is complete. The components of the Hydro-Kinetic tank equipment package that will be cast-in the tank include a through-wall pipe coupling, a clarification outlet coupling and a vent for the aeration riser cover. The remainder of the tank equipment package consists of subassemblies S1, S2 and S3, which are installed after casting is complete. Certain tanks, such as one-piece castings and Singulair tanks that have been converted to Hydro-Kinetic, require additional equipment to be installed before delivery to the installation site. For these tanks, the distributor must provide and install outlet tees for the pretreatment chamber and the Hydro-Kinetic Bio-Film Reactor, and an inlet elbow for the aeration chamber. All other tank configurations have these components integrated into the castings.

TANK DELIVERY AND SETTING (Page 2 of 6)

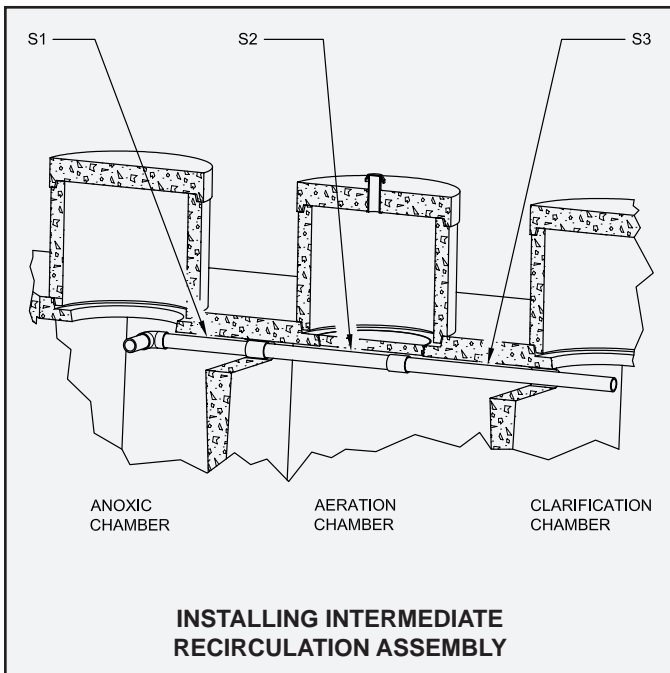

For a one-piece tank and Singulair conversions, solvent weld the 4" Schedule 40 PVC pretreatment outlet tee to the coupling that was cast-in the outlet end of the pretreatment chamber (distributor to provide). Solvent weld the 4" Schedule 40 PVC aeration chamber transfer elbow into the coupling cast-in the inlet of the aeration chamber (distributor to provide). When installing the intermediate recirculation assembly for all systems, begin in the anoxic chamber and solvent weld subassembly S1 into the coupling that was cast-in the wall between the anoxic and aeration chambers. The elbow should be oriented as shown with the short stub of pipe parallel to the floor and ceiling of the tank. Solvent weld subassembly S2 into the aeration chamber side of the same cast-in coupling.

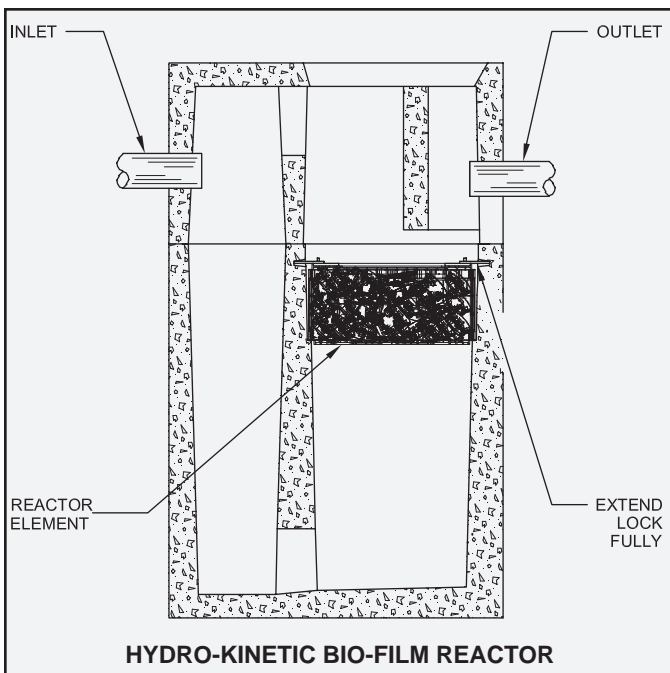

Starting in the aeration chamber, pass subassembly S3 through the wall into the clarification chamber. Solvent weld subassembly S3 to the coupling on subassembly S2.

Carefully place both Reactor Elements into the Hydro-Kinetic Bio-Film Reactor. They will rest on the ledge cast into the outlet chamber of the Hydro-Kinetic Bio-Film Reactor. The Reactor Elements should be installed with the media service hatch oriented toward the middle of the tank and facing up. Using the universal tool, slide the locking mechanisms outward on each Reactor Element so that they lock into the recesses cast into the tank.

CHECKING THE EXCAVATION

When installing a Hydro-Kinetic system, first check the length, width and depth of the excavation. If installing a Model 600 FEU system with a separate Hydro-Kinetic Bio-Film Reactor, insure the excavation is long enough to allow at least 2' between the treatment tank and the Hydro-Kinetic Bio-Film Reactor for installation of the interconnect plumbing and backfill between the tanks. If installing a separate pretreatment tank, insure the excavation is long enough to allow at least 2' between the pretreatment and anoxic chambers for installation of the interconnect plumbing and backfill between the tanks. Cut a 4" Schedule 40 PVC pipe (distributor to provide) 6" longer than the distance between the tanks for the interconnect plumbing. Insert the interconnect pipe into the inlet of the Hydro-Kinetic Bio-Film Reactor prior to tank placement. This allows the interconnect pipe to be backed straight out and solvent welded into the cast-in outlet coupling of the clarification chamber when the tanks are set. The excavation should have sufficient overdig to allow for a minimum of 6" clearance around the entire perimeter of the system. Additional overdig will be required on deep installations or where unstable soil conditions exist. Safe working conditions must be established and maintained during installation.

Prepare the excavation to the appropriate depth based on the elevation of the building sewer line. Allow $\frac{1}{8}$ " of fall per foot from the building to the system. Fall through the Model 600 system is 4" from inlet invert to outlet invert. In the Model 600 FEU that includes the Hydro-Kinetic Bio-Film Reactor, fall through the system is 5" from inlet invert to outlet invert. Therefore, the outlet line from the system must be installed either 4" or 5" lower than the inlet sewer line. No additional fall between the clarification chamber and Hydro-Kinetic Bio-Film Reactor is required.

MANUFACTURED BY

norweco

Engineering the future of water and wastewater treatment.

**NORWECO, INC.
NORWALK, OHIO
U.S.A. 44857**

www.norweco.com

HYDRO-KINETIC®

WASTEWATER TREATMENT SYSTEM

TANK DELIVERY AND SETTING (Page 3 of 6)

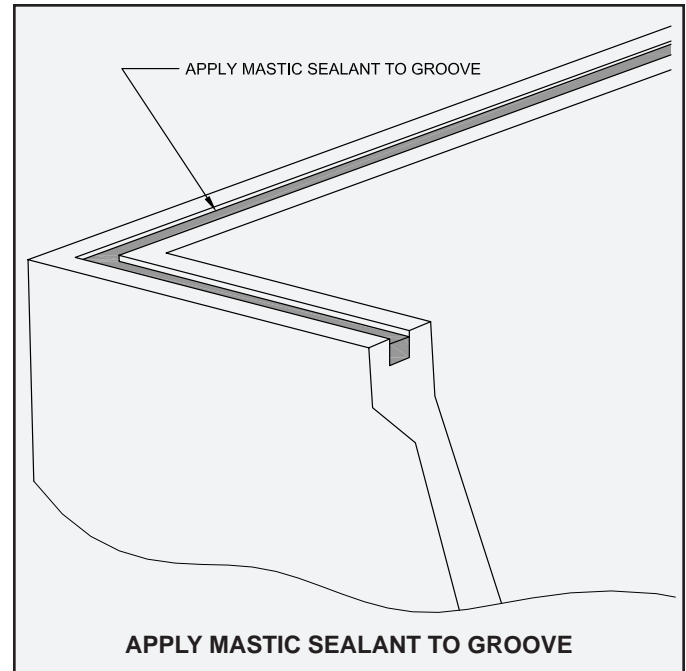
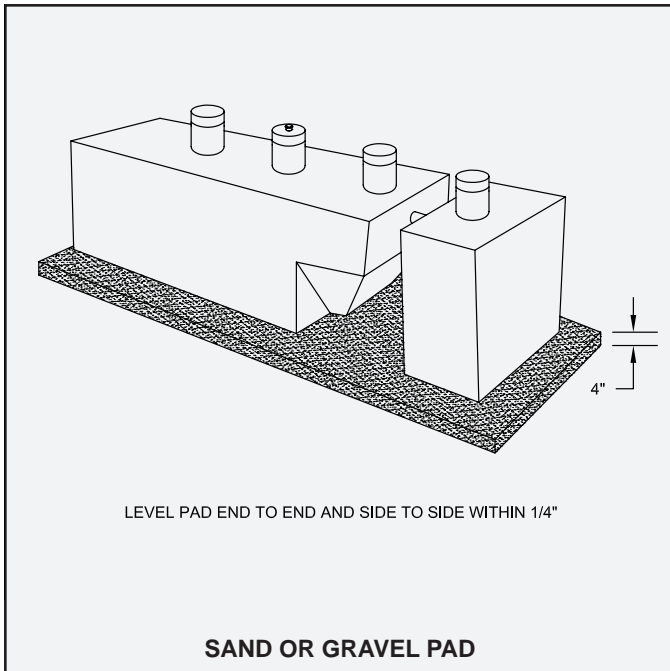

A tank leveling pad should be installed in the bottom of the excavation. The pad should be a minimum of 4" thick and leveled to within $\frac{1}{4}$ " from side to side and end to end. The elevation of the top of the leveling pad should correspond to the outside bottom of the Hydro-Kinetic precast concrete tankage when installed. Be sure that the height from the top of the leveling pad to grade will allow for the correct influent and effluent line connections.

Extreme care should be used any time personnel or equipment are in the vicinity of any excavation. A delivery truck can place excessive loading on excavation sidewalls and care must be taken in its positioning. Unstable soil conditions require constant monitoring of the site to insure safety. Construction and installation procedures, equipment, tools, materials and personnel should always comply with applicable safety regulations and federal, state and local codes.

HYDRO-KINETIC TANK SEALING

While the tank bottoms are still on the delivery truck, remove any concrete chips, stones, mud or debris from the groove in the castings and from the floor of the pretreatment, anoxic and aeration chambers. Be sure the transfer ports are clean and unrestricted. Apply a good quality mastic sealant into the groove of the bottom casting around the entire perimeter and fully across all internal baffles. Inspect the sealant after application to eliminate any gaps or uneven spots. A non-shrinking grout sealant may be used in place of mastic, but mastic will allow the tank to be filled with water immediately after its installation.

TREATMENT TANK SETTING AND SAFETY

With the delivery truck in position at the excavation, make sure that its outriggers are firmly placed on stable soil. All personnel must be out of the excavation and a safe distance from the tank. Before lifting the treatment tank, check all lifting chains to be sure they are properly seated in the casting pick-up grooves. Lift the tank bottom section and place it directly into the excavation. Do not set it down. Stop the casting several inches above the excavation floor and position it in the desired location. Then lower it carefully until all tension is off the lifting cable or chain.

Place a level on the exposed joint and check the casting for level from end to end and side to side (if the tank is set as one piece, check for level on the top). It must be level within $\frac{1}{4}$ " from end to end and from side to side. The casting may need to be raised slightly so additional leveling pad material can be applied before level is achieved. If the casting needs to be raised more than six inches to apply leveling material, personnel should move to a safe location so the casting can be fully returned to the bed of the delivery truck. The casting should then be reset after the excavation has been properly leveled.

The top casting may now be set. Remove all debris from the bottom of the casting along the tongue sealing section. Do not reach or get under any portion of the casting. Carefully position the top and lower one corner into the groove. Align the sides of the casting and lower the top into position. Recheck the tank for level from side to side and end to end.

TANK DELIVERY AND SETTING (Page 4 of 6)

ACCESS RISER AND OPTIONAL EXTENSION RISER INSTALLATION

Locate the power cable entrance in the aeration chamber riser casting. It should be inspected for flash or sharp edges. Be sure it extends all the way through the casting side wall. Remove the cast-in access cover from the top of the aeration chamber. Apply a strip of mastic sealant around the perimeter of each access opening. Position and install the aeration mounting casting with the power cable entrance facing the tank side wall that is closest to the building. Be sure that the mounting casting is properly seated on the tank top and evenly sealed with mastic. If extension riser castings are required, install them as needed above the aeration chamber riser casting. Apply mastic sealant to all joints between castings. Do not apply sealant to the top riser that will receive the vented access cover. The anoxic chamber and Hydro-Kinetic Bio-Film Reactor have both above grade risers and below grade access openings. None of the access covers on these chambers are to be vented.

On the Bio-Film Reactors, use the universal tool to insure each of the locking mechanisms is fully engaged. Slide the locking mechanisms outward until they clear the locking ledge. Apply mastic sealant to all joints between castings on these chambers and install risers and access openings.

The pretreatment chamber can be made accessible at grade or left below grade, as required by local regulation or owner preference. The inspection cover on the pretreatment chamber must at least be developed to within twelve inches of finished grade. Pretreatment chamber access covers should never be vented and should be sealed with mastic. Be sure all cast-in access opening covers that are not extended to grade are properly aligned, seated and securely in place. Tank covers which have been replaced by mounting castings should be returned to your plant with the delivery truck. Install all covers for risers and inspection ports before backfilling begins.

SEWER LINE INSTALLATION

Sewer lines may be installed as soon as the Hydro-Kinetic concrete tankage has been leveled and sealed. Sewer line trenches must be smoothly excavated and free of debris or sharp objects that could damage the installation. The trenches must allow sewer lines to be laid with $\frac{1}{8}$ " of fall per linear foot of run along the entire length of the line. Influent and effluent sewer lines must be at least 4" in diameter. Connect the building sewer line to

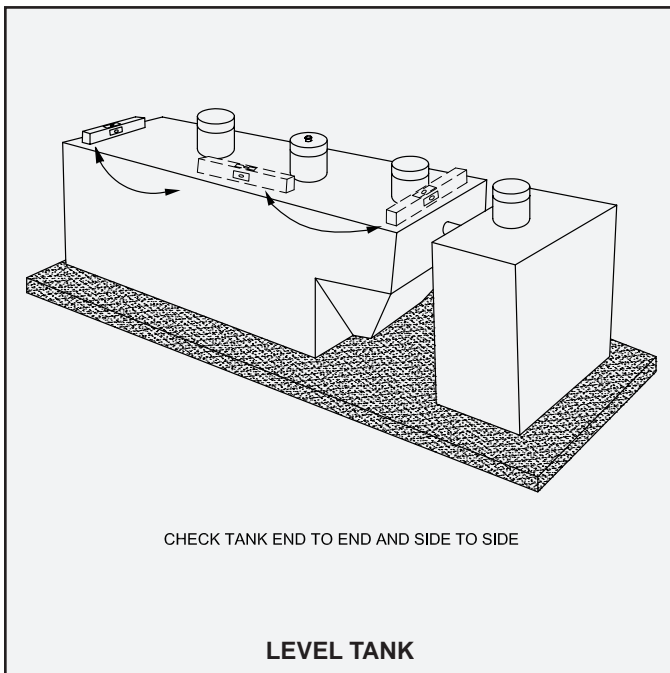

MODEL 600 FEU BIO-FILM REACTOR SETTING

Allow Hydro-Kinetic at least 2' between the treatment tank and the Bio-Film Reactor. Lift the bottom section and place it in the excavation. Do not set it down. Stop the casting several inches above the excavation floor and position it in the desired location. Lower it carefully until all tension is off the lifting cable or chain.

Place a level on the exposed joint and check the casting for level from end to end and side to side (if the tank is set as one piece, check for level on the top). It must be level within $\frac{1}{4}$ " from end to end and from side to side. The casting may need to be raised slightly so additional leveling pad material can be applied before level is achieved. If the casting needs to be raised more than six inches to apply leveling material, personnel should move to a safe location so the casting can be fully returned to the bed of the delivery truck. The casting should then be reset after the excavation has been properly leveled. Once level, apply mastic sealant into the groove of the bottom casting around the entire perimeter and fully across all internal baffles.

Prior to lifting the top casting, insert the interconnect piping into the inlet of the Bio-Film Reactor casting far enough to allow clearance between the clarification chamber and the Bio-Film Reactor. The interconnect piping will be backed out and solvent welded to the clarification chamber outlet coupling after the top casting is installed.

The top casting may now be set. Remove all debris from the bottom of the casting along the tongue sealing section. Do not reach or get under any portion of the casting. Carefully position the top and lower one corner into the groove. Align the sides of the casting and lower the top into position. Recheck the tank for level.

MANUFACTURED BY

norweco[®]

Engineering the future of water
and wastewater treatment.

**NORWECO, INC.
NORWALK, OHIO
U.S.A. 44857
www.norweco.com**

HYDRO-KINETIC®

WASTEWATER TREATMENT SYSTEM

TANK DELIVERY AND SETTING (Page 5 of 6)

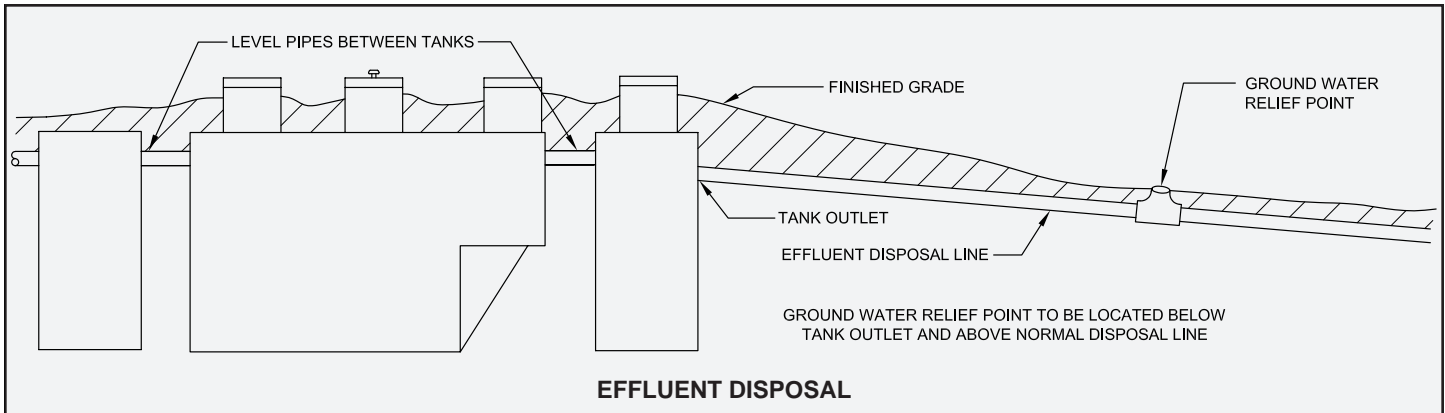

the pretreatment chamber inlet. The effluent line should be PVC pipe, solvent welded into the clarification chamber outlet coupling. If installing a Model 600 FEU, back the interconnect pipe out of the Bio-Film Reactor and solvent weld the pipe to the outlet coupling of the clarification chamber. Then, connect the discharge sewer line to the Bio-Film Reactor outlet. Inlet and outlet lines must be laid continuously and unspliced from the tank to undisturbed earth beyond the limits of the tank excavation. If using a one-piece tank, insert the discharge sewer line through the tank outlet seal, leaving 4" - 6" protruding inside the tank. Solvent weld the 4" Schedule 40 PVC outlet tee (distributor to provide) to the discharge sewer line. High quality PVC or other similar materials may be used for sewer lines, subject to approval of local codes. Be sure the sewer lines are constructed with compatible fittings and joining materials throughout. Underground electrical cable for service to the pumps should be installed in the sewer line trench before backfilling. Refer to Model 801P Control Center Installation and Operation instructions for complete details.

GROUND WATER RELIEF POINT

The effluent sewer line should be installed with a ground water relief point to prevent back-up into the system if the effluent discharge point or absorption system is blocked or flooded. This device can be constructed by installing a pipe tee in the effluent sewer line and extending it to grade. The outlet must be at a lower elevation than the outlet invert of the Hydro-Kinetic system. The extension to grade should be installed with a suitable grate to prevent access to the sewer line.

PRIOR TO BACKFILLING

For installations where the air pump will not be located in the aeration riser, install a 3/4" Schedule 40 PVC air line from the air pump to the system. The air line should be buried in a trench at a recommended depth of at least 12 inches. Protect the air line in a casing pipe if heavy loading is anticipated. The air line must be run into the aeration riser and the opening in the riser sealed with mortar or approved sealant.

Perform a visual inspection of the entire system before backfilling begins. Be sure the tank outlet and all transfers are free from obstructions. Check that there is sufficient fall in the inlet and outlet lines of the tank. Remove any dirt or debris from sealing surfaces such as those between the risers and covers. Insure tank has remained level within 1/4" from side to side and end to end. The system is now ready for backfilling.

BACKFILLING

The system should be backfilled immediately after sewer lines and underground electrical cables are installed. Fine, loose earth should be used to backfill the tank excavation and sewer line trenches. Be sure it is completely free of rocks, large clumps of earth and construction debris. Use fine granular material when backfilling around electrical

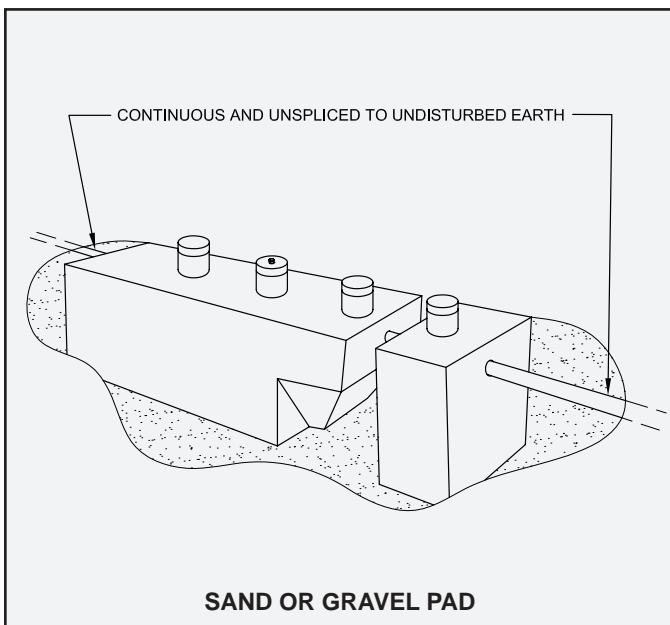

TANK DELIVERY AND SETTING (Page 6 of 6)

cables and conduits. The underground electrical cables should have at least 2' of earth cover. If the proposed finished grade will not permit this coverage, the cables should be installed in approved conduit from the tank to the building foundation. Backfill evenly around the entire perimeter of the tank rather than all at once on each side. Take care to completely fill in the cavity beneath the slanted clarifier end wall in order to provide the necessary support for this area of the casting.

Final grading should be 6" below the top of each riser access cover and should slope away from the tank so surface runoff will drain away from the system. Use extreme care in backfilling. Do not allow dirt or mud to enter any part of the treatment system or sewer lines. If dirt or mud enters any portion of the system, it must be removed to insure proper system operation. Removing the dirt or mud may require repeated flushing and tank pumping.

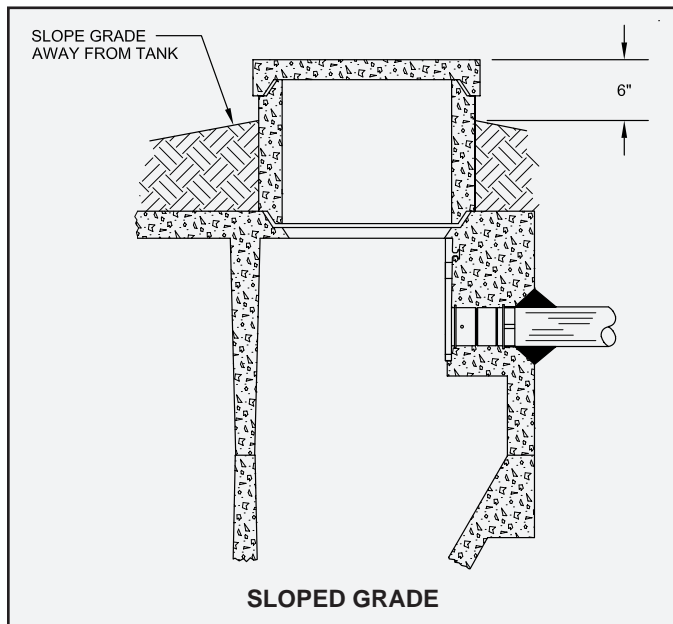

TANK HOLD DOWN WATER

Each compartment of the treatment system must be filled with clean water to the outlet invert immediately following backfilling. Filling with water prevents tank shifting and insures the proper pressure distribution throughout the casting. The water must be free of leaves, mud, grit or other materials that might interfere with system operation. Do not fill the treatment system with water through the opening in the top of the clarification chamber. The clarification chamber will be filled by adding water to the aeration chamber.

This completes the portion of the installation that requires a delivery truck for tank lifting and setting. Installation of the electrical control center and underground electrical cable are normally completed by the delivery truck driver before leaving the site. Refer to the Model 801P Control Center Installation and Operation instructions for details.

ALTERNATE TANK CONFIGURATIONS

The Hydro-Kinetic system is available in several different tank configurations. The entire system can be housed in a single five chamber casting, a four chamber casting with a separate Hydro-Kinetic Bio-Film Reactor casting, or can be split into three castings with external filter and pretreatment castings. There are advantages to each configuration. When installing a Singlair tank that has been converted to a Hydro-Kinetic tank, the pretreatment and filter chambers need to be plumbed to the three-chamber anoxic, aeration and clarification tank. Most of the system installation guidelines remain the same regardless of the tank configuration. If installing a system with a pretreatment chamber that is not integrated, this tank must maintain the same 2' spacing as between the filter and the clarification chambers, and is plumbed using the same technique. The inlet and outlet plumbing must be unspliced to beyond the limit of the earth displaced during the excavation no matter which tank configuration is installed.

The standard overdig distance of 6" should be maintained when installing a separate pretreatment tank. This distance should be extended when dealing with deep installations or where unstable soil conditions exist. The same 4" layer of gravel, sand or fine crushed stone should be used for a separate pretreatment tank, and must be leveled to within 1/4" from side to side and end to end. Remember to establish and maintain safe working conditions during the entire installation procedure.

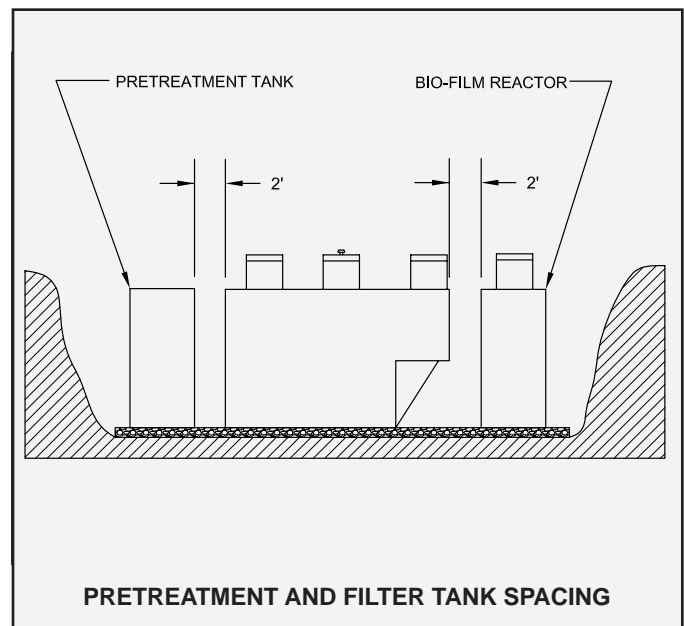

MANUFACTURED BY

norweco

Engineering the future of water
and wastewater treatment.

NORWECO, INC.
NORWALK, OHIO
U.S.A. 44857
www.norweco.com

norweco® **SERVICE PRO**®

MODEL 801P CONTROL CENTER WITH MCD TECHNOLOGY

INSTALLATION AND OPERATION INSTRUCTIONS

The advanced integrated circuitry of the Service Pro control center simplifies the Hydro-Kinetic installation, improves system performance and allows for communication with the Service Pro website. The control center insert and enclosure provide space for power and communication wiring, as well as the communication module. The integrated circuitry continually monitors both recirculation pump over current and under current conditions and minimizes nuisance alarm conditions using the automatic restart feature. To reduce unnecessary service calls, the control center shuts down the recirculation pump in the event of an over current or an under current alarm condition, illuminates the alarm light and begins an automatic two hour recirculation pump restart attempt sequence before activating the audible alarm and telemetry system.

Service Pro Model 801P control centers are available with an automatic telemetry system designed to communicate through a toll free telephone number or an Internet connection. In the event of an alarm condition that cannot be corrected by the control center's self-diagnostic sequence, the telemetry system contacts the Service Pro remote monitoring center. The monitoring center identifies the alarming control center and logs the time that the message was received and specific alarm condition reported. The monitoring center then automatically updates the website and notifies the responsible Norweco distributor or service provider by email, fax or telephone. In addition to documenting alarm conditions, the website tracks the date, time and duration of service visits, service contract renewals and maintains a complete database for every Hydro-Kinetic system registered. Access to the information is password protected and available to licensed distributors, sponsored service providers, health departments and system owners.

These instructions are not intended to be a complete electrical, telecommunication or network system installation reference. Telecommunication and network system policies as well as electrical code requirements vary according to geographic area. Consult your local policies and regulations prior to installing the Service Pro control center. Refer to the Electrical Wiring and Control Center Installation instructions for additional details.

INSTALLATION OF ELECTRICAL CONTROL CENTER

1. Electrical work must be performed in accordance with the latest edition of the National Electrical Code as well as applicable local codes.
2. All underground electrical service cable used with the Hydro-Kinetic system must be UL and CSA approved, type UF, #14/2 AWG minimum and must have a full-size center ground. Larger cable is required if the length of the underground service is greater than 80 feet. Consult your electrician for details.
3. An approved cable must be installed from the air pump to the junction box provided for connection to the control center. If installing the air pump in a location other than the aeration chamber riser, insure the air line is no more than 75' in length and the air pump is protected from the elements in a clean, dry, well-ventilated area and proceed to step 6.
4. Inspect the power cable entrance in the side of the aeration chamber riser. Remove any sharp edges or flash. Insert the free end of the power cable through a pre-formed 1/2" conduit ell (2' by 1'), then into the power cable entrance of the aeration riser. Guide the power cable into the riser. Pull enough cable through the riser to reach 36" above the riser top. Coil and secure the cable in the aeration chamber riser so that it will not hang down in the tank.

5. Lay the conduit ell with cable directly across the top and down the tank side. Do not allow the power cable to be laid across the end of the tank or any removable access cover. Seal the connection between the conduit and the aeration riser with mortar or approved sealant.

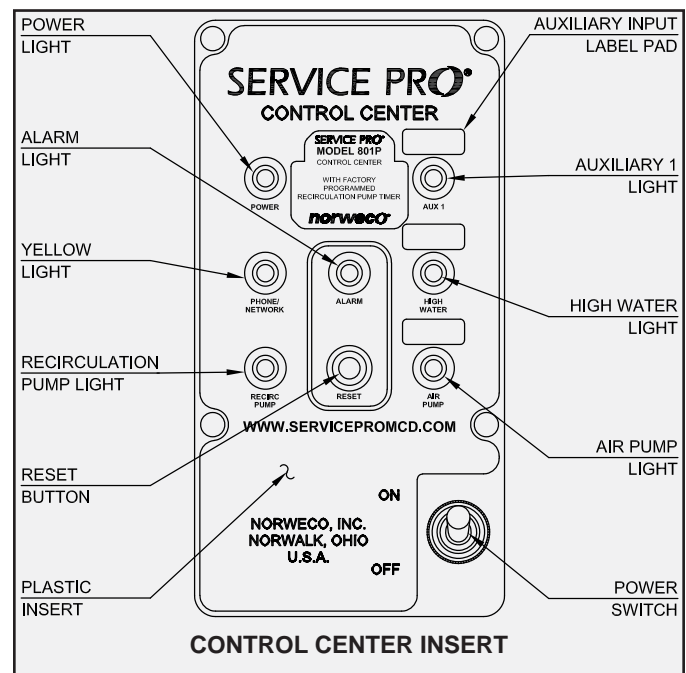

SERVICE PRO® 801P CONTROL CENTER INSTRUCTIONS (Page 2 of 8)

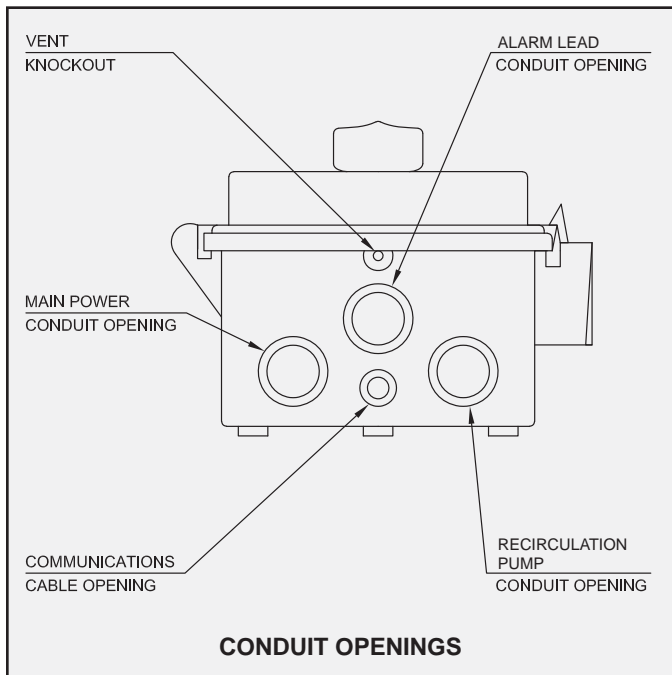

12. Uncoil the electrical service cables into the excavation and influent sewer line trench. Leave sufficient slack in the cables so they will not be stressed or pulled tight during backfill or settling.
13. Always encase the electrical cables in conduit any time they are above finished grade. Route the conduits and cables as directly as possible to the control center mounting location.

COMPLETING THE INSTALLATION

1. The control center should be wired for operation when the tank and underground electrical cables are installed. The control center should be located so that the red warning light can be seen and the audible alarm heard. The mounting location should minimize exposure to direct sunlight, freezing rain or conditions that might prevent routine inspection or access. The control center should always be mounted out of the reach of children.

6. A second underground cable must be installed unspliced from the control center into the clarification riser to supply power to the recirculation pump.
7. Inspect the power cable entrance in the side of the concrete clarification riser. Remove any sharp edges or flash. Insert the free end of the power cable through a pre-formed ½" conduit ell (2' by 1'), then into the power cable entrance of the clarification riser. Guide the power cable into the riser. Pull enough cable through the riser to reach 36" above the riser top. Coil and secure the cable in the clarification riser so that it will not hang down in the tank.
8. Lay the conduit ell with cable directly across the top and down the tank side. Do not allow the power cable to be laid across the end of the tank or any removable access cover. Seal the connection between the conduit and the clarification riser with mortar or approved sealant.
9. Two alarm leads must be installed from the air pump pressure switch to the Service Pro control center. The alarm leads should be #16 AWG minimum and installed in conduit where contact with concrete may occur. **IMPORTANT:** Alarm leads and power leads must always be installed in separate conduits.
10. Two alarm leads must be installed from the high water float switch to the Service Pro control center. The alarm leads should be #16 AWG minimum and installed in conduit where contact with concrete may occur. **IMPORTANT:** Alarm leads and power leads must always be installed in separate conduits. If the air pump will be installed in the aeration riser, the high water and air pump alarm leads should be installed in the same conduit. Properly seal the conduit opening in the riser with mortar or approved sealant.
11. Check the excavation and sewer line trenches to be sure they are free of debris, rocks and any sharp or abrasive objects that could damage electrical cables or alarm leads during backfill or settling.

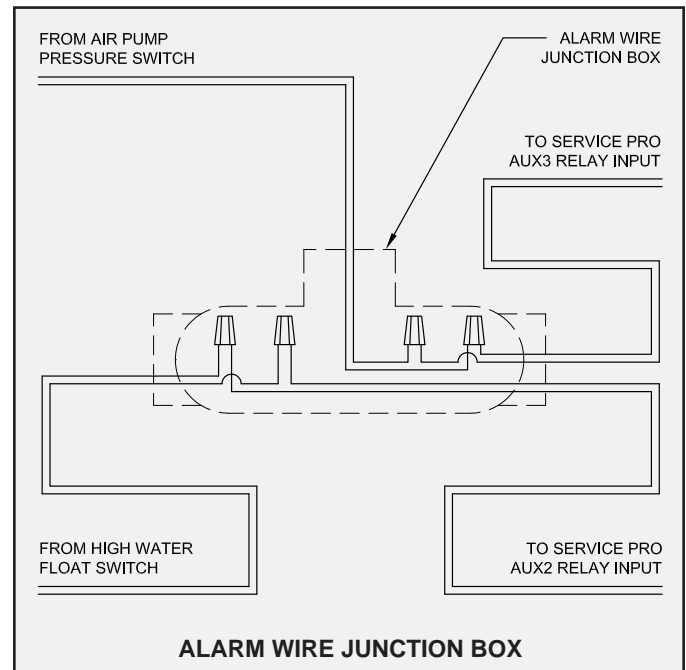

2. Remove the cover from the alarm wire junction box connected to the float switch. Solvent weld the junction box to the conduit containing the alarm leads, located in the aeration chamber riser.
3. Reference the schematic wiring diagram shown on page 3 for all wiring instructions. The black and white alarm wires contained in the alarm wire junction box are provided to connect the float switch to the Service Pro control center. Connect the black wire in

MANUFACTURED BY

norweco[®]

Engineering the future of water and wastewater treatment

NORWECO, INC.
NORWALK, OHIO
U.S.A. 44857
www.norweco.com

SERVICE PRO®

801P CONTROL CENTER WITH MCD TECHNOLOGY

INSTALLATION AND OPERATION (Page 3 of 8)

the junction box to either alarm lead from the control center, and secure with a wire nut connector. Connect the white wire in the junction box to the remaining alarm lead from the control center, and secure with a wire nut connector.

4. If the air pump is installed in the aeration chamber riser, solvent weld the conduit connection for the pressure switch alarm cable to the junction box. Connect the black wire in the pressure switch cable to either alarm lead from the panel, and secure with a wire nut connector. Connect the white wire in the pressure switch cable to the remaining alarm lead from the panel, and secure with a wire nut connector.
5. Reinstall and secure the cover on the alarm wire junction box. Plug any unused junction box openings.
6. Proceed to the control center. Detach the cover from the control center enclosure and remove the insert from the mounting posts. Set the control center insert aside. Remove the knockouts in the bottom of the enclosure and install a sealed conduit connector (distributor to provide) in each opening. Exposed wiring to or from the control center should always be encased in conduit. Mount the control center securely using masonry nails, wood screws or common nails as appropriate.
7. Use a dedicated 115 VAC, single-phase circuit at the main electrical service panel. A 15 amp circuit is recommended (10 amp minimum). **CAUTION: Make sure the circuit is de-energized. Check it with an electrician's test light before proceeding. Remember that other circuits in the service panel may remain energized as you are working. Use only tools with insulated handles, stand in a dry location and work with extreme care.**

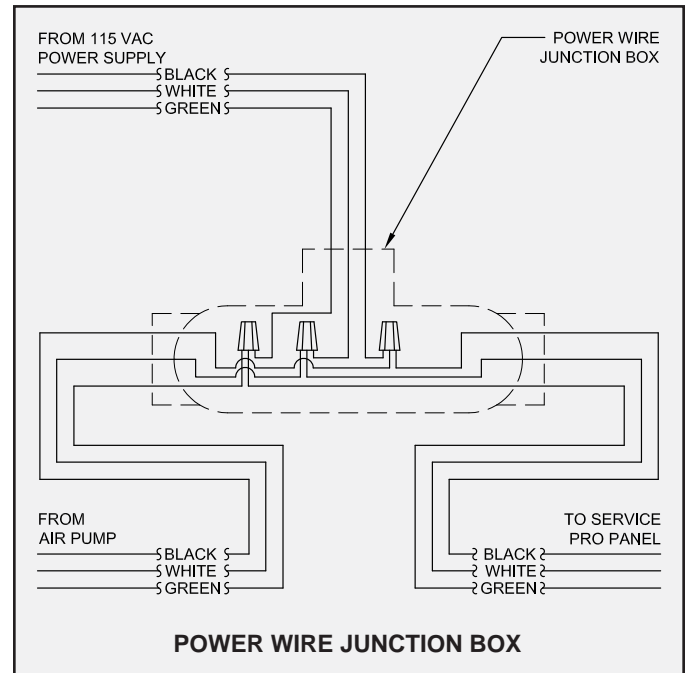

8. Open the insulator on the back of the control center insert to access the power and alarm wiring connections.
9. Install a #14/2 AWG minimum cable with full-size center ground from the control center to the power wire junction box provided for connection to the control center.
10. Wire from the dedicated circuit breaker in the main service panel to the power wire junction box. Use at least #14 AWG black copper wire. Connect the black wire from the main service panel to the black wire in the air pump power cable and the black wire to the control center. Secure with a wire nut connector.

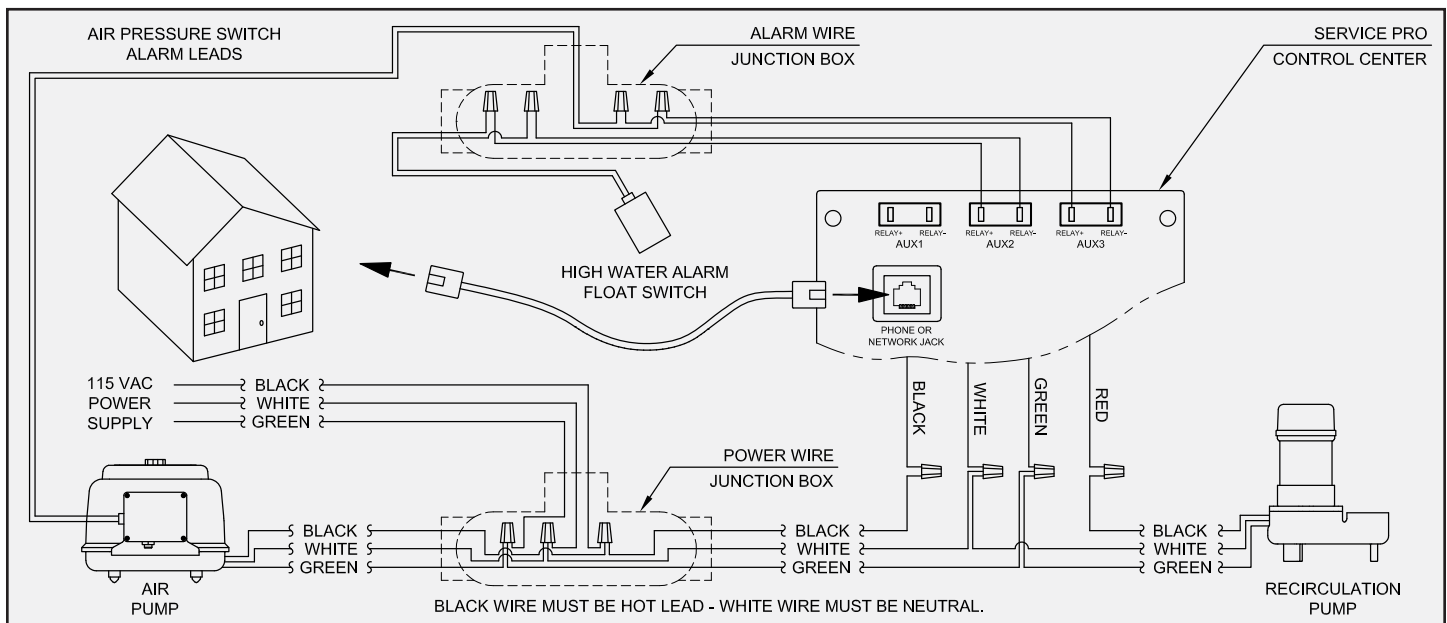

SERVICE PRO® 801P CONTROL CENTER INSTRUCTIONS (Page 4 of 8)

11. Wire from the neutral in the main service panel to the junction box. Use at least #14 AWG white copper wire. Connect the white wire from the main service panel to the white wire from the air pump power cable and the white wire to the control center. Secure with a wire nut connector.
12. Connect the ground wire from the main electrical service panel to the non-insulated ground lead from the air pump and the ground wire to the control center. Secure with a wire nut connector. **IMPORTANT:** Never allow the white neutral leads and the ground leads to be spliced together.
13. Install the cover on the junction box and proceed to the control center.
14. Connect the black wire from the junction box to the black wire on the control center. Secure with a wire nut connector.
15. Connect the black lead of the underground electrical cable from the recirculation pump to the red wire on the Service Pro control center and secure with a wire nut connector.
16. Connect the white wire from the junction box to the white wire from the recirculation pump and white wire on the Service Pro control center. Secure with a wire nut connector.
17. Connect the ground wire from the junction box to the non-insulated ground lead from the recirculation pump and the green wire on the control center. Secure with a wire nut connector. **IMPORTANT:** Never allow the white neutral leads and the ground leads to be spliced together.
18. Connect the alarm leads from the high water float switch to the AUX2 RELAY terminals on the control center.
19. Connect the alarm leads from the air pump pressure switch to the AUX3 RELAY terminals on the control center.

20. If the remote monitoring features of the control center will be utilized, refer to the PHONE OR NETWORK CABLE INSTALLATION section of this document.

IMPORTANT: Never install the communication cable in a conduit with power lines.

21. Check all wiring connections after wiring has been completed. Make sure all wires are properly secured in each wire nut connector. Correct any wiring issues before proceeding.
22. Carefully form all wiring neatly into the lower part of the control center. Do not allow the wires to make contact with other electrical components in the control center. The conduit openings in the enclosure must now be sealed using expanding foam sealant (available from Norweco).
23. Close the black insulator and snap the control center insert into position. Reinstall and close the control center cover. Secure it with the Norweco tamper evident seal.
24. Clearly label the dedicated circuit breaker used for the Hydro-Kinetic system on the door of the main service panel. Replace the service panel deadfront and enclosure cover.

ALARM INPUTS

The Service Pro control center will accept alarm inputs that generate several different types of output: a 5 to 120 volt AC or DC signal, a normally open relay circuit or a normally closed relay circuit. The inputs on the control center are male 0.110" quick connect terminals and accept standard female 0.110" insulated quick connect receptacles. When connecting to the alarm inputs:

1. Determine the type of output that will be generated by the alarm device you wish to connect. The high water and air pump alarms use normally open relay circuits.
2. Route the leads through one of the conduits not being used for power lines into the bottom of the enclosure. Be sure to pull enough wire to comfortably reach the two AUX 1 auxiliary terminals you will be connecting to on the back of the control center insert.
3. Crimp the insulated female 0.110" quick connect receptacles to the ends of the alarm leads.
4. Connect the leads to the corresponding auxiliary alarm inputs. When connecting a relay circuit, connect to the "RELAY +" and "RELAY -" terminals. For a voltage input, connect the leads to the auxiliary alarm terminals marked "V+" and "V-".

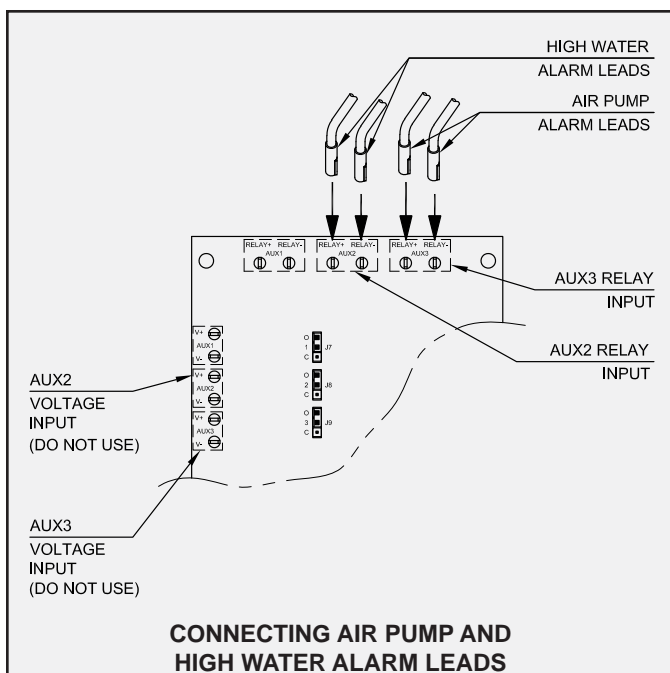

MANUFACTURED BY

norweco®

Engineering the future of water
and wastewater treatment

NORWECO, INC.
NORWALK, OHIO
U.S.A. 44857

www.norweco.com

SERVICE PRO®

801P CONTROL CENTER WITH MCD TECHNOLOGY

INSTALLATION AND OPERATION (Page 5 of 8)

IMPORTANT: Never connect a voltage input to the RELAY terminals on the circuit board. This may damage the controls and will void the warranty.

- When connecting a device that uses a relay contact setting, you will need to set the jumper for the correct relay configuration. If the alarm circuit is normally closed, place the jumper over the bottom two jumper pins closest to the 'C' label. If the alarm circuit is normally open, place the jumper over the top two jumper pins closest to the 'O' label.

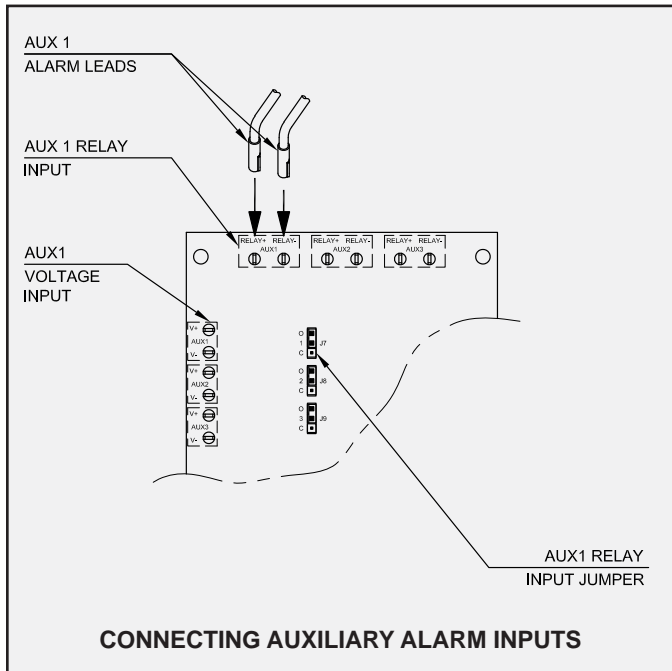

PHONE OR NETWORK CABLE INSTALLATION

If a telephone connection will be utilized, a telephone line must be installed unspliced from the telephone box to the Service Pro control center. Before installing the telephone line, familiarize yourself with the equipment and policies of the local telephone service provider. The Service Pro control center is not compatible with digital telephone service. With DSL Internet service, a DSL filter will need to be connected to the telephone jack on the Service Pro controls to insure proper operation of the monitoring feature. If a telephone line is not available, one will need to be installed by the local telephone service provider or an Internet communication module should be utilized.

If an Internet connection will be utilized, a network cable must be installed from the Internet connection in the home to the Service Pro control center. The network cable will typically be plugged into a switch or router that distributes Internet service in the home. Regardless of whether the communications will take place through a phone line or the

Internet, the following steps must be performed to complete system wiring:

- Make sure the dedicated circuit breaker in the main service panel is in the "off" position. Using the alarm input conduit or one of the grommets provided, run the telephone or network cable into the bottom of the enclosure. The appropriate knockout will need to be removed from the bottom of the Service Pro control center enclosure before the cable can be installed. NOTE: The telephone or network cable cannot be installed into a conduit with any power lines. Crimp the appropriate phone or network jack on the communications cable in the control center.
- Connect the telephone or network cable into the jack provided on the control center. Connect the other end of the communications cable to the existing telephone system or home Internet service.
- Confirm the phone or network module is securely seated into the socket on the main control circuit board.
- Snap the control center insert into position. Close the control center cover.

The Model 801P is available with the network module, the telephone module or without either communication module installed. The modules are interchangeable and can be added or exchanged in the field. If you are exchanging modules, first insure power is off and remove the existing module from the circuit board by unplugging it from the socket. To install a new module, snap the new module onto the two plastic standoffs on the circuit board and securely plug the module into the socket provided.

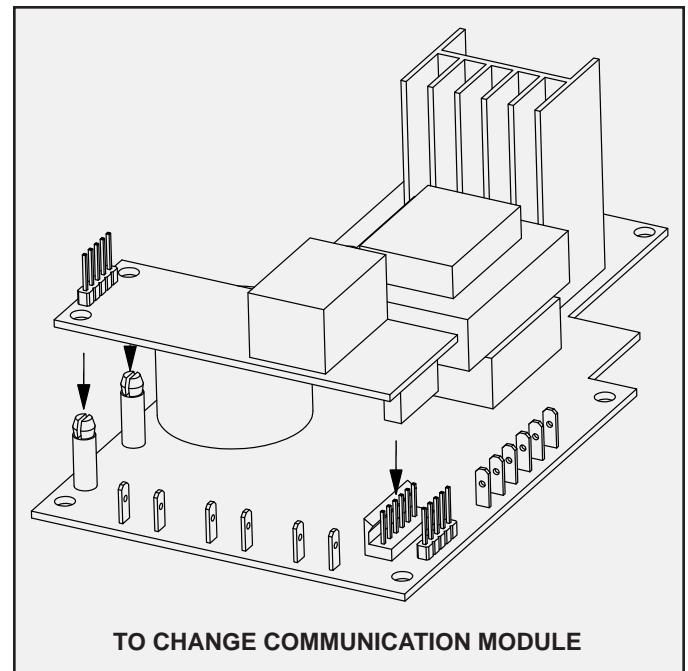

SERVICE PRO® 801P CONTROL CENTER INSTRUCTIONS (Page 6 of 8)

TELEMETRY SYSTEM COMMISSIONING

Each control center is shipped with the integrated telemetry system disabled. All other monitoring, diagnostic and local alarm functions will operate as designed. The reset button is used to enable the integrated telemetry system once the communications cable has been connected. This process is referred to as commissioning the control center. Commissioning notifies the Service Pro monitoring center that the control center is functional and ready to transmit information.

To commission the control center, insure the dedicated circuit breaker in the main service panel is in the “on” position and the communications cable is properly installed. Place the control center selector switch in the “off” position. While holding in the reset button, place the selector switch in the “on” position. Continue to hold the reset button until the red alarm light illuminates. Release the reset button and allow the telemetry system up to sixty seconds to call out and complete the commissioning process. The yellow light will illuminate during the call out process.

If commissioning is successful, the alarm light will flash 5 short flashes and stop as verification. If commissioning is unsuccessful, the alarm light will flash a pattern that indicates the cause of the failed communication. The pattern will display repeatedly. If the commissioning is not successful, refer to the table on page 7 for troubleshooting information. Conduct an alarm test to confirm commissioning was successful. If the yellow light does not illuminate during the alarm test, recommission the panel and refer to the table on page 7.

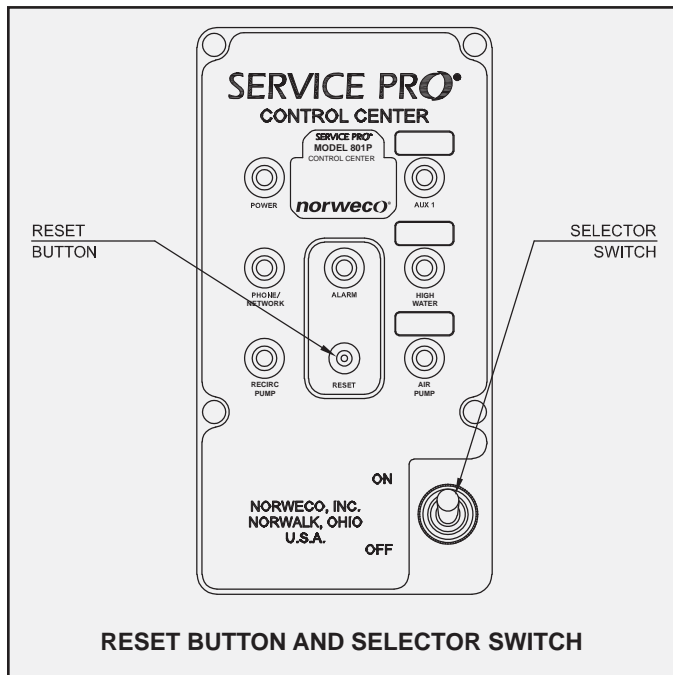

RESET BUTTON

The reset button on the Service Pro control center is used to perform multiple tasks during installation and operation. To activate the reset button, apply pressure with your index finger. The button is activated when a “click” is heard.

The reset button can be used to silence the audible alarm, turn on the recirculation pump when it is in an off cycle or restart the run cycle when the recirculation pump is running. The reset button is also used to test the control center audible and visual alarms and telemetry system. **NOTE: To prevent damage to the control center, excessive pressure on the reset button should be avoided.**

To test the alarms, press and hold the reset button for approximately five seconds until the audible and visual alarms activate and then release. If the control center is equipped with a communications module, the panel will call out and deliver an alarm test message to the Service Pro monitoring system. Once the communication is complete, the yellow light will turn off and the control center will return to normal operation.

The reset button can also be used to record service visits. When arriving on site, press and hold the reset button for five seconds until the alarm test feature activates, then release the button. The panel will call to record the start of the service visit. After the control panel has completed the alarm test call, routine service should be performed on the Hydro-Kinetic system. Once system service has been completed, press and hold the reset button again for five seconds until the alarm test feature activates. The Service Pro control center will register two alarm test calls received within a four hour period as a service visit. The date, time and duration of the service visit will be logged in the database for future reference.

RECIRCULATION PUMP TIMER

Each control center is supplied with a timer that determines the run time of the recirculation pump. The timer is factory preset and should not be adjusted.

ALARM CONDITION OPERATING SEQUENCE

When the control center detects an over current or an under current alarm condition, the alarm light will activate and flash a code that specifies the alarm condition that was detected. If an under current or open motor condition is detected, the alarm light will flash two short flashes. If an over current condition is detected, the alarm light will flash steadily. If either an over current or an under current alarm condition is detected, the recirculation pump is shut down and an automatic system restart sequence begins. With

MANUFACTURED BY

norweco®
Engineering the future of water
and wastewater treatment

NORWECO, INC.
NORWALK, OHIO
U.S.A. 44857
www.norweco.com

SERVICE PRO®

801P CONTROL CENTER WITH MCD TECHNOLOGY

INSTALLATION AND OPERATION (Page 7 of 8)

the alarm light flashing, the control center will automatically attempt to restart the recirculation pump every five minutes for a period of two hours (24 restart attempts). The control center monitors pump current during each restart attempt. If the proper level of current is detected, the control center returns the pump to normal operation and turns off the alarm light. Pressing the reset button while the alarm light is flashing causes the control center to attempt to restart the recirculation and counts toward the 24 restart attempts. If the recirculation pump does not restart after 24 attempts, the audible alarm and the alarm light activate.

After both audible and visual alarms are activated, press the reset button and the control center will attempt to restart the recirculation pump again. If the proper current level is not detected, the audible alarm beeps three times, then silences. The alarm light continues to flash and the control center interrupts power to the recirculation pump. If the alarm condition is not corrected and the control center resets after 48 hours, the audible alarm will automatically reactivate. If a control center problem is detected, the alarm light will illuminate continuously and the audible alarm will activate. If a high water, air pump or auxiliary alarm condition is detected, the audible alarm and the corresponding auxiliary alarm light will activate.

If the telemetry system on the Service Pro control center has been commissioned, the system will then attempt to call out after a five minute delay and deliver an alarm

message. The system will call the Service Pro monitoring center every 48 hours until the alarm condition is corrected and the control center is reset. The Service Pro control center uses advanced diagnostic technology to monitor the Hydro-Kinetic system for proper operation. In the event an alarm condition is encountered, the control center will display a series of flashes from the alarm light located in the center of the control panel (refer to the Red Alarm Light Diagnostic Codes chart below for further reference).

SYSTEM HEARTBEAT FEATURE

The Service Pro control center contains a system heartbeat feature that will call out every 30 days to inform the monitoring center that the Hydro-Kinetic treatment system is functioning as designed. If the heartbeat call is not received, the monitoring center will notify the distributor or service provider that service is required at that system location.

POWER FAILURE MONITORING

The Service Pro Model 801P control center includes circuitry that detects and reports power failure conditions. In the event that power is disconnected from the control center, either by a power outage or by turning off the power switch in the control center, the control center will place a call to the Service Pro monitoring center one hour after power has been restored to report the outage.

RED ALARM LIGHT DIAGNOSTIC CODES	
CONDITION	RED ALARM LIGHT FLASH PATTERN
Successful commissioning	Flash 5 short and stop
Alarm test	Flash 10 short and stop
Service visit start	
Service visit end	
Communications cable not plugged in	Flash 1 short, 1 long - pause 3 seconds & repeat
Phone line in use in home	Flash 2 short, 1 long - pause 3 seconds & repeat
Number called is busy	Flash 3 short, 1 long - pause 3 seconds & repeat
Remote monitoring center error	Flash 4 short, 1 long - pause 3 seconds & repeat
Phone service terminated	
Service Pro panel communication error	Flash 5 short, 1 long - pause 3 seconds & repeat
Control failure	Illuminate continuous
Recirculation pump under current	Flash 2 short - pause 3 seconds & repeat
Recirculation pump open motor	Flash 2 short - pause 3 seconds & repeat
Recirculation pump over current	Flash evenly until serviced
Auxiliary one alarm	
High water alarm	
Air pump alarm	

SERVICE PRO® 801P CONTROL CENTER INSTRUCTIONS (Page 8 of 8)

FCC COMPLIANCE

This equipment complies with Part 68 of the FCC rules and the requirements adopted by the ACTA. The label on the inside of the control center cover contains, among other information, a product identifier in the format US:S2KMM00BMCD. If requested, this number must be provided to the telephone company.

If the Service Pro control center causes harm to the telephone network, the telephone company will notify you in advance that temporary discontinuance of service may be required. But if advance notice isn't practical, the telephone company will notify the customer as soon as possible. Also, you will be advised of your right to file a complaint with the FCC if you believe it is necessary.

The telephone company may make changes in its facilities, equipment, operations or procedures that could affect the operations of the equipment. If this happens the telephone company will provide advance notice in order for you to make necessary modifications to maintain uninterrupted service.

If trouble is experienced with the Service Pro control center, for repair or warranty information, please contact Norweco, Inc. If the equipment is causing harm to the telephone network, the telephone company may request that you disconnect the equipment until the problem is resolved.

SERVICE PRO WEBSITE & REGISTRATION

The telemetry system, available with the Service Pro Model 801P control center, is engineered to interface with the Service Pro monitoring center. The Service Pro monitoring center allows the homeowner, service provider, licensed Norweco distributor and authorized regulatory entities to access Hydro-Kinetic wastewater treatment system records online. Records generated by the Service Pro control center (heartbeat record, alarm conditions, service records) can be accessed at www.servicepromcd.com. For access to the website, contact your local distributor or Norweco, Inc.

WARNING: The Service Pro Model 801P control center is designed to monitor residential wastewater treatment equipment only. Connection of household appliances or other unauthorized equipment may damage equipment and void the Hydro-Kinetic system warranty.

Permanent record retention and remote monitoring of the Hydro-Kinetic system will begin when the following steps have been completed:

- The "Add New Subscriber" section of the website has been completed by the Hydro-Kinetic distributor or service provider.
- The system is started up and the Service Pro control center is commissioned.

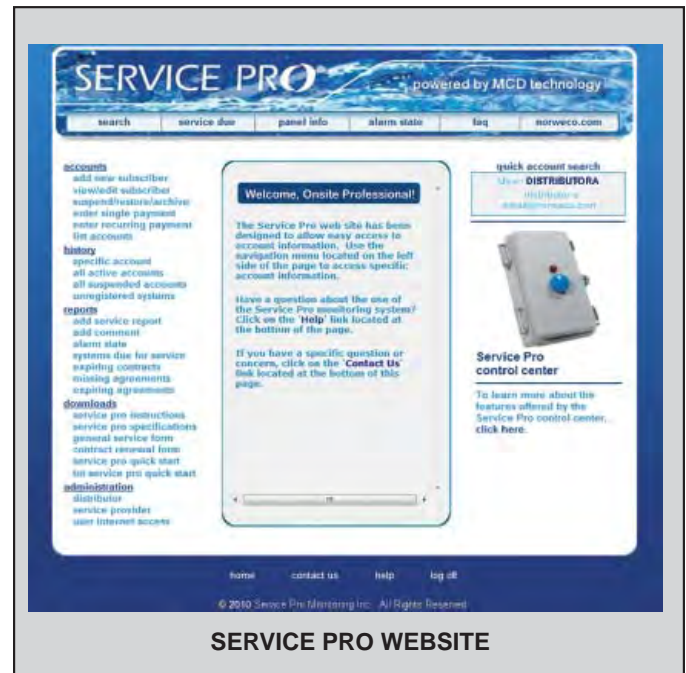

- Three copies of the signed Service Pro Subscriber Monitoring Agreement are received by Norweco.

The Service Pro control center can be commissioned either before or after the new account has been registered with the Service Pro monitoring center. However, if the commissioning step is performed first, the registration of the new account must be completed within 30 days of commissioning.

The Getting Started Website Instructions provide details on registering a new account on the Service Pro website. Add each new account by using the information recorded on the Monitoring Agreement form.

The Monitoring Agreement is completed with the owner of each system to be monitored by the website. The top three copies of the Agreement should be submitted to Norweco. This activates monitoring and satisfies Norweco's warranty registration procedure. Each new subscriber must sign a 24 month monitoring agreement. If the monitoring agreement is not received by Norweco, Inc. within 60 days of the new account being commissioned, the account will be suspended until the monitoring agreement is received. To insure continuous monitoring, agreements are automatically renewed. Initial and renewal Hydro-Kinetic service contracts should include the cost to provide the Service Pro monitoring service. Refer to the Subscriber Monitoring Agreement Guide for further information.



norweco® **HYDRO-KINETIC**®

WASTEWATER TREATMENT SYSTEM

AIR PUMP AND PIPING INSTALLATION

Installation of the Model A100 air pump, Model SD103 recirculation pump, and associated plumbing should take place when the Hydro-Kinetic wastewater treatment system is ready for start-up. Refer to the Recirculation Pump and Piping Installation instructions for specific details regarding recirculation system installation. Your delivery truck driver should have instructed the contractor or owner to contact your office and make arrangements for equipment installation to coincide with occupancy and sanitary sewer use. Review your Hydro-Kinetic tank setting records weekly to insure that you do not have equipment installations that are overdue. If you suspect that adequate time has passed for system start-up and you have not yet heard from the owners, contact them to schedule equipment installation.

PRE-INSTALLATION CHECKLIST

- ✓ The installer should have accurate directions to the facility and a list of service inspections due at other installations in the vicinity.
- ✓ The service vehicle should carry the Hydro-Kinetic Tool Kaddy fully stocked with tools, spare parts and test equipment for use during installation.
- ✓ The installer should have the Hydro-Kinetic Product Manual.
- ✓ The owner or contractor should be present at the location to allow installer access to the control center and electrical service panel.
- ✓ The main electrical service panel wiring must be complete so the air pump may be started-up and tested.
- ✓ All chambers of the Hydro-Kinetic tankage should be full to the flow line.
- ✓ The serial number on the air pump must match the service and warranty record card.

AIR PUMP START-UP PROCEDURE

When you arrive on site, introduce yourself to the owner and ask to see the main electrical service panel and Service Pro control center. Be certain each circuit for the Hydro-Kinetic system in the main electrical service panel is de-energized and that the power switch in the Service Pro control center is placed in the "off" position. Explain to the owner that you will be installing the air pump and piping in the tank and you will need access to the main electrical service panel for system start-up after the air pump and piping have been installed. Carry the air pump and piping in its shipping carton to the tank site. Place the Hydro-Kinetic Tool Kaddy nearby for easy access to tools and test equipment. Remove the vented cover from the aeration chamber riser casting. Carefully remove the Model A100 air pump and air piping components from the shipping carton. For installations where the air pump will not be located in the riser, refer to the Remote Installation of Air Pump section of this document.

AIR PIPING COMPONENTS

The air piping components of the concrete Hydro-Kinetic system are:

1. Diffuser (Subassembly A1)
2. Diffuser Drop Pipe Assembly (Subassemblies A2-A4)
3. Primary Air Assembly (Subassemblies A5, A6)

AIR PUMP AND PIPING INSTALLATION

1. Remove the contents from red mesh bag with components labeled "AIR". Attach diffuser bar A1 to subassembly A2 at union. Securely tighten union by hand.
2. Solvent weld subassembly A2 to subassembly A3. Insure red arrows are aligned.

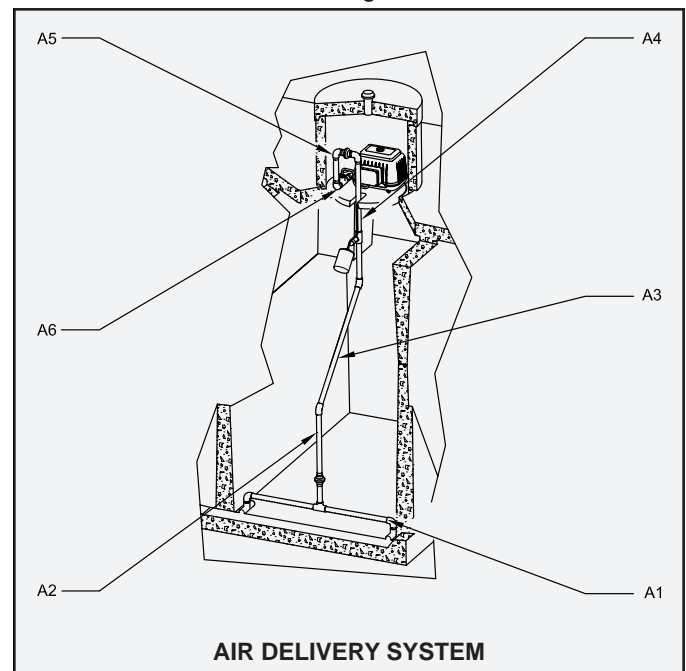

AIR PUMP AND PIPING INSTALLATION (Cont.)

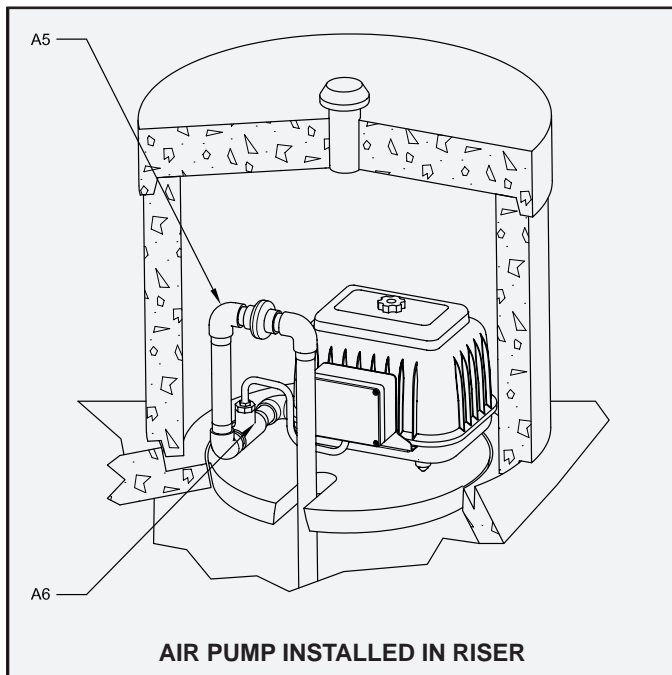

AIR PUMP INSTALLED IN RISER

3. Solvent weld subassembly A3 to subassembly A4. Insure blue arrows are aligned.
4. Install the drop pipe assembly into aeration chamber by bending the flexible tubing. Lower assembly into the tank until the diffuser bar contacts both the floor and side wall of the tank.
5. If the air pump will be installed in the aeration chamber riser, solvent weld subassembly A5 to subassembly A6. Insure yellow arrows are aligned. Install the air pump concrete mounting pad in the aeration chamber riser.
6. Install the air pump in the aeration chamber riser on the air pump concrete mounting pad (or in a clean, dry, well-ventilated area protected from the elements no more than 75' from the tank). Attach subassembly A4 to subassembly A5 at union. Securely tighten union by hand.
7. To wire the air pump female electrical connector, unscrew the three captive stainless steel screws from the face of the female connector. They will stay in the body of the receptacle. Lift out the rigid internal receptacle body. Unscrew the compression nut on the strain relief connector. Insert the electrical service cable through the compression nut, compression ring and neoprene grommet.
8. Strip the outer insulation back 1¼" on the underground electrical service cable and expose the three individual leads. Use extreme care to be sure the insulation jackets on the individual black and white leads are not scarred or damaged while stripping the outer jacket.
9. Strip off the insulation jackets 7/16" from the ends of the individual black and white leads.
10. Insert the black lead into the hole adjacent to the brass-colored screw and tighten the screw securely.
11. Insert the white lead into the hole adjacent to the silver-colored screw and tighten the screw securely.

12. Insert the bare copper ground lead into the hole that is adjacent to the green-colored screw and tighten the screw securely.
13. Align the insert key on the receptacle body with the keyway molded into the rubber sleeve. Press the receptacle body into the sleeve and tighten the three stainless steel screws on the face of the connector. Press the grommet into the electrical connector and tighten the compression nut.
14. Plug in the air pump and check the air piping for leaks. Use a soapy water solution to thoroughly coat the piping and check for bubbles. Repair any leaking pipe or fitting and retest.

REMOTE INSTALLATION OF AIR PUMP

If required, the air pump can be remotely installed in a location other than the aeration chamber riser. Remote installation requires a riser that has been modified to allow for the passage of the Schedule 40 PVC air line.

1. Route the piping through the riser wall in an orientation that allows for the removal of the air pump concrete mounting pad at the bottom of riser, and subassemblies A1-A4. After passing the PVC air line through the riser wall, dry fit a 90 degree elbow and subassembly A5 to the end of the air line passing through riser wall and insure proper orientation.
2. After confirming that the orientation of the air delivery piping will allow sufficient access, solvent weld air line, elbow and subassembly A5 together.
3. Mount the air pump in a location that will remain clean and dry no more than 75' from the tank. The pump should be easily accessible for service without the need to contact the owner. The air pump should be mounted close enough to the power supply to avoid the use of extension cords. The air pump electrical connection can be directly plugged into a standard outlet, or can be wired through a junction box.
4. Route the air line from the riser to the air pump location. The air line should be buried at a minimum depth of 2' for protection. If loading is expected, the air line can be placed in a larger outer conduit pipe.
5. Subassembly A6 should always be mounted directly to the pump in both standard and remote installations. A6 has a fitting for attaching the hose for the pressure switch which controls the pump. The pressure switch is located in the housing attached to the side of the pump. The cable exiting the housing must either be wired directly to the control panel, or through a junction box.

MANUFACTURED BY

norweco[®]

*Engineering the future of water
and wastewater treatment.*

**NORWECO, INC.
NORWALK, OHIO
U.S.A. 44857**

www.norweco.com

norweco® **HYDRO-KINETIC**®

WASTEWATER TREATMENT SYSTEM

RECIRCULATION PUMP AND PIPING INSTALLATION

Installation of the Model A100 air pump, Model SD103 recirculation pump, and associated plumbing should take place when the Hydro-Kinetic wastewater treatment system is ready for start-up. Refer to the Air Pump and Piping Installation instructions for specific details regarding air delivery system installation. Your delivery truck driver should have instructed the contractor or owner to contact your office and make arrangements for equipment installation to coincide with occupancy and sanitary sewer use. Review your Hydro-Kinetic tank setting records weekly to insure that you do not have equipment installations that are overdue. If you suspect that adequate time has passed for system start-up and you have not yet heard from the owners, contact them to schedule equipment installation.

PRE-INSTALLATION CHECKLIST

- ✓ The installer should have accurate directions to the facility and a list of service inspections due at other installations in the vicinity.
- ✓ The service vehicle should carry the Hydro-Kinetic Tool Kaddy fully stocked with tools, spare parts and test equipment for use during installation.
- ✓ The installer should have the Hydro-Kinetic Product Manual.
- ✓ The owner or contractor should be present at the location to allow installer access to the control center and electrical service panel.
- ✓ The main electrical service panel wiring must be complete so the recirculation pump may be started-up and tested.
- ✓ All chambers of the Hydro-Kinetic tankage should be full to the flow line.
- ✓ The serial number on the recirculation pump must match the service and warranty record card.

RECIRCULATION PUMP START-UP PROCEDURE

When you arrive on site, introduce yourself to the owner and ask to see the main electrical service panel and Service Pro control center. Be certain each circuit for the Hydro-Kinetic system in the main electrical service panel is de-energized and that the power switch in the Service Pro control center is placed in the "off" position. Explain to the owner that you will be installing the recirculation pump and piping in the tank and you will need access to the main electrical service panel for system start-up after the recirculation pump and piping have been installed. Carry the recirculation pump and piping in its shipping carton to the tank site. Place the Hydro-Kinetic Tool Kaddy nearby for easy access to tools and test equipment. Remove the access covers from the anoxic and clarification chamber risers. Carefully remove the recirculation pump and recirculation piping components from the shipping carton.

RECIRCULATION PIPING COMPONENTS

The recirculation piping components of the concrete Hydro-Kinetic system are:

1. Intermediate Recirculation Assembly (Subassemblies S1-S3)

2. Primary Recirculation Assembly (Subassemblies S4-S7)
3. Mixing Bar Drop Pipe Assembly (Subassemblies S8, S10-S12)
4. Mixing Bar (Subassembly S9)

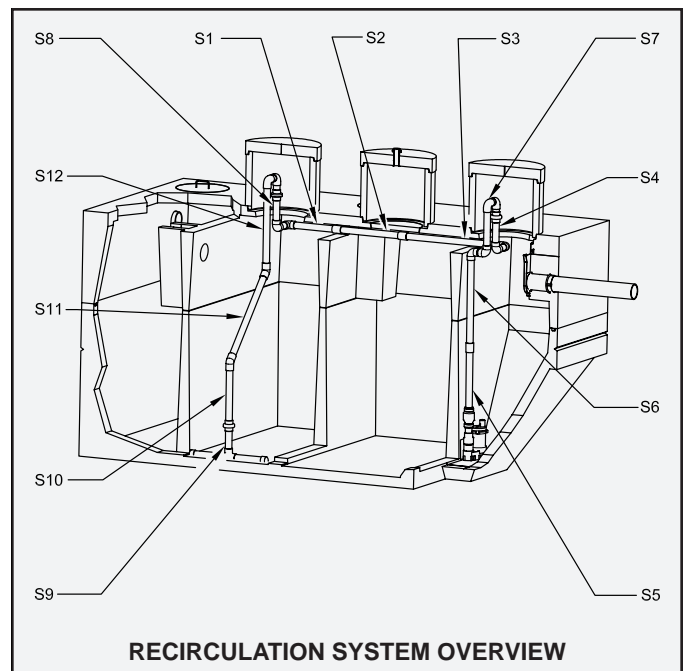

RECIRCULATION PUMP AND PIPING INSTALLATION (Cont.)

RECIRCULATION PUMP AND PIPING INSTALLATION

In the clarification chamber:

1. Remove the contents from black mesh bag with components labeled "SLUDGE". Solvent weld subassembly S3 to subassembly S4 in the clarification chamber (S3 was installed with the tank equipment package). Be sure the union is facing up.
2. Thread subassembly S5 into the pump discharge.
3. Solvent weld the coupling on subassembly S5 to subassembly S6.
4. Solvent weld subassembly S6 to subassembly S7.
5. Attach pump cord to the pump discharge assembly (S5-S7) using cable ties provided.
6. Use discharge assembly to lower pump into the clarification chamber until pump rests on the floor of the hopper. Attach subassembly S4 to subassembly S7 at union. Securely tighten union by hand.

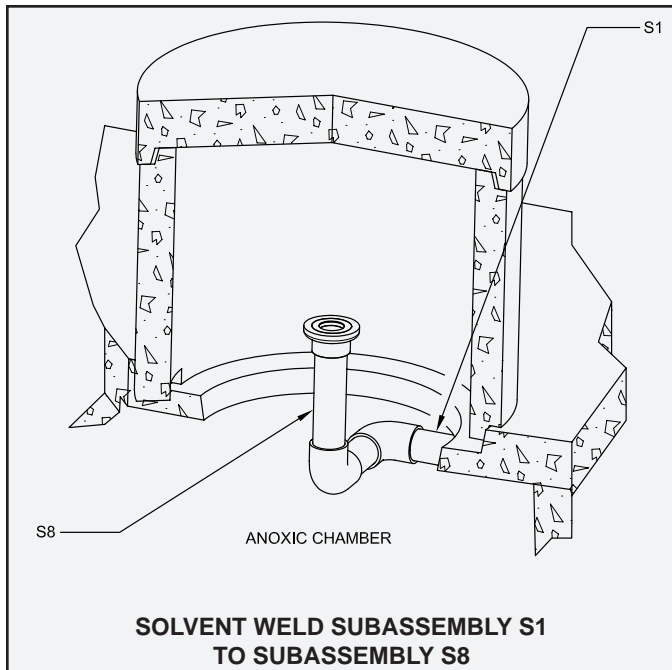
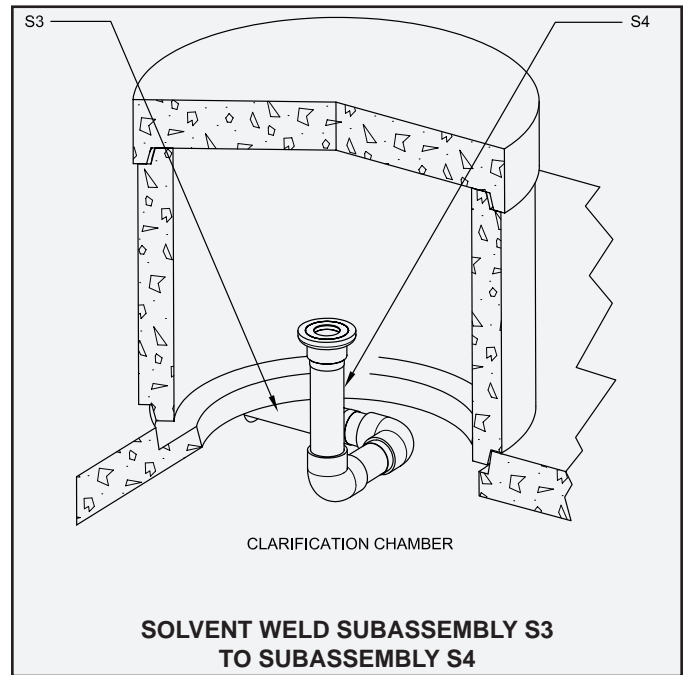

In the anoxic chamber:

7. Solvent weld subassembly S1 to subassembly S8 (S1 was installed with the tank equipment package). Be sure the union is facing up.
8. Attach subassembly S9 to subassembly S10 at union. Securely tighten union by hand.
9. Solvent weld subassembly S10 to subassembly S11. Insure yellow arrows are aligned.
10. Solvent weld subassembly S11 to subassembly S12. Insure green arrows are aligned.
11. Bend mixing bar assembly at flexible tubing and lower into anoxic chamber until mixing bar is positioned as shown. Attach subassembly S12 to subassembly S8 at union. Securely tighten union by hand.
12. Wire the recirculation pump female electrical connector. Unscrew the three captive stainless steel screws from the face of the female connector. They will stay in the body of the receptacle. Lift out the rigid internal receptacle body. Unscrew the

compression nut on the strain relief connector. Insert the electrical service cable through the compression nut, compression ring and neoprene grommet.

13. Strip the outer insulation back 1/4" on the underground electrical service cable and expose the three individual leads. Use extreme care to insure the insulation jackets on the individual black and white leads are not scarred or damaged while stripping the outer jacket.
14. Strip off the insulation jackets 7/16" from the ends of the individual black and white leads.
15. Insert the black lead into the hole adjacent to the brass-colored screw and tighten the screw securely.
16. Insert the white lead into the hole adjacent to the silver-colored screw and tighten the screw securely.
17. Insert the bare copper ground lead into the hole that is adjacent to the green-colored screw and tighten the screw securely.
18. Align the insert key on the receptacle body with the keyway molded into the rubber sleeve. Press the receptacle body into the sleeve and tighten the three stainless steel screws on the face of the connector. Press the neoprene grommet into the electrical connector and tighten the compression nut.
19. Plug the male connector on the recirculation pump power cord into the female connector.
20. Install the flow equalization device by sliding it into the tank receiving flange in the clarification chamber. Insure the device is completely seated in the flange.

MANUFACTURED BY

norweco[®]

*Engineering the future of water
and wastewater treatment.*

NORWECO, INC.
NORWALK, OHIO
U.S.A. 44857
www.norweco.com

norweco® **HYDRO-KINETIC**®

WASTEWATER TREATMENT SYSTEM FINAL CHECK & SYSTEM START-UP

Immediately following installation of the Model A100 air pump, Model SD103 recirculation pump, and piping, the entire Hydro-Kinetic system should be given a final check and start-up. All tests should be performed to insure equipment is installed and operating properly. After all tests are satisfactorily completed, the power switch in the Service Pro control center should be set to "on" position. The air pump and recirculation pump should not be turned off, even during extended vacation periods. If the system will not be operated for an extended period of time, the air pump should be removed from the system and properly stored. Instruct the owner to contact the local distributor regarding extended periods of non-use.

CAUTION: *Any time an air pump, recirculation pump or electrical test equipment is connected or disconnected, first shut off the power switch located in the Service Pro control center. Failure to do so could result in personal injury or equipment damage. Always insure safe work procedures are followed.*

PRELIMINARY ELECTRICAL INSPECTION

Inspect the control center for damage that might have occurred after its installation. Inspect all visible wiring to and from the control center. Report any damage to the owner at once; it must be corrected before proceeding with electrical testing.

Make sure the circuit breaker which supplies power to the Hydro-Kinetic system in the main electrical service panel is in the "off" position. Open the control center cover and place the power switch in the "off" position. Proceed to the Hydro-Kinetic system and unplug the watertight electrical connectors from the recirculation pump and air pump power cords. Secure the closure caps in position on the electrical connectors and return to the control center.

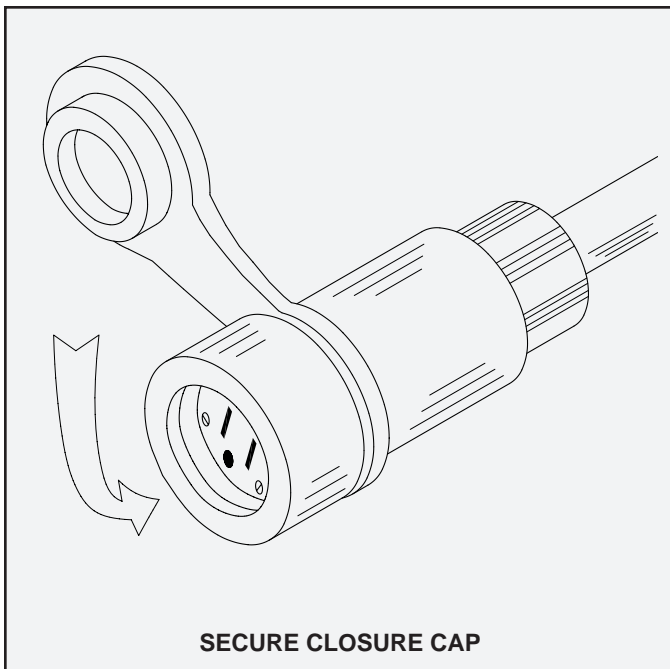

VOLTAGE TEST OF CONTROL CENTER

Use the multi-meter provided in the Hydro-Kinetic Tool Kaddy to check the voltage in the Service Pro control center. Energize the circuit breaker in the main electrical service panel. Always follow safe work procedures when power to the system is energized.

Place one probe of the meter from the Tool Kaddy in the wire nut connector attached to the black wire and one probe in the wire nut connector attached to the white wire. It should read between 109 and 121 volts. Place one probe of the meter in the wire nut connector attached to the red wire and one probe in the wire nut connector attached to the white wire. The meter should read zero volts.

Place one probe in the wire nut connector attached to the green wire and the other probe in the wire nut connector attached to the white wire. The meter should read zero volts. Once these readings are confirmed, place the power switch in the "off" position, carefully reinstall the insert and proceed to the air pump.

VOLTAGE TEST OF AIR PUMP AND RECIRCULATION PUMP

Remove the polarity tester from the Tool Kaddy and insert it into the receptacle of the air pump electrical connector. When the circuit is energized, the polarity tester should indicate proper wiring of the connector and control center. Remove the polarity tester and insert one probe of the multi-meter into each slot of the electrical connector. It should read between 109 and 121 volts. **CAUTION: Do not energize the system if an electrical problem is found.** Advise the owner and return only when the problem condition has been corrected by a qualified electrician. Repeat the voltage test for the recirculation pump.

HYDRO-KINETIC® SYSTEM FINAL CHECK & SYSTEM START-UP (Cont.)

AMPERAGE TEST

Remove the electrical test pigtail from the Tool Kaddy and place the current sensor of the multi-meter around the exposed black lead of the test pigtail. Plug the test pigtail in line between the two halves of the watertight electrical connector of the recirculation pump. When energized, read the current draw of the recirculation pump. The initial reading should never be greater than 6.5 amps. After 48 hours of operation, break-in of the mechanical seals will allow the amp draw to drop to 6.0 amps or less. If an excessive current reading is obtained, de-energize the recirculation pump immediately and do not re-energize it until the cause is found and corrected. When the test is complete, place the control center power switch in the "off" position, unplug the test pigtail at both ends and plug the recirculation pump directly into the receptacle on the underground electrical service cable. Make sure the two halves of the connector are firmly engaged to insure the integrity of the multiple lip seal for a moisture proof connection. Place the power switch in the "on" position.

AIR PUMP AND PIPING INSPECTION

Remove the vented cover from the aeration chamber riser casting. Check the air pump to make sure it is running smoothly without excessive vibration. Check the diffuser assembly to be sure it is operational and creating a rolling motion of the aeration chamber contents. Replace the vented cover over the aeration chamber riser casting and check for excessive noise. Listen for evidence of debris in the aeration chamber striking the diffuser. Occasionally, discarded construction materials may enter the sewer line and Hydro-Kinetic tank. They must be removed at once so that air delivery from the diffuser is not impeded. Inspect the vent cap openings to assure the unrestricted passage of air.

RECIRCULATION PUMP AND PIPING INSPECTION

Remove the access cover from the anoxic and clarification chamber riser castings. Check the recirculation pump to make sure it is running smoothly and that the mixing bar is operational. Replace the access cover over the anoxic and clarification chamber riser castings. Listen for evidence of debris in the anoxic chamber striking the mixing bar. Occasionally, discarded construction materials may enter the sewer line and Hydro-Kinetic tank. They must be removed at once so that recirculated liquid from the mixing bar is not impeded.

INSPECTION OF BIO-FILM REACTOR

Remove the access cover from the Bio-Film Reactor access opening. Inspect the Bio-Film Reactor to be sure that it is installed in a level position and that the locking mechanisms are fully engaged to insure proper operation of the Reactor Elements. Replace the access cover.

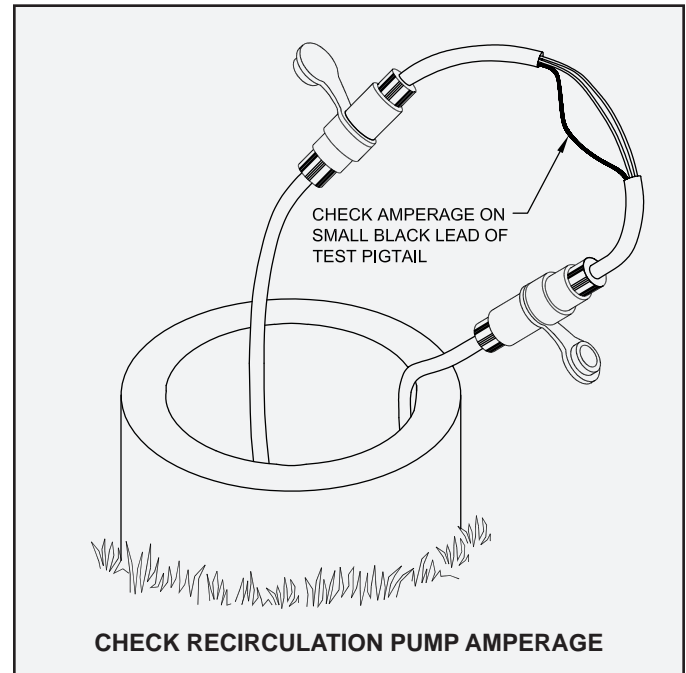

INSPECTION OF EFFLUENT DISPOSAL SYSTEM

Inspect the final discharge point to make sure that the outlet is unrestricted. If you suspect any possibility of a drainage problem, report it to the owner and request that corrective action be taken immediately. The system could be subjected to high water and liquid may back up into the inlet sewer line if not corrected. Locate the ground water relief point and insure it is clean and unobstructed.

When an effluent lift pump or other accessory equipment has been installed as part of the Hydro-Kinetic system, these items must be started-up, and placed into operation at this time. Refer to the individual start-up instructions furnished with accessory equipment and test them accordingly.

WHEN YOUR INSPECTIONS ARE COMPLETE

Place the power switch in the Service Pro control center in the "on" position. Latch the control center cover and secure it with a tamper evident seal. Notify the owner that the Hydro-Kinetic system is operating properly. Ask if there are any questions regarding system operation. Most start-up problems are caused by improper or incomplete installation of the system or because of a misunderstanding on the part of the contractor or owner. Refer to the Hydro-Kinetic Troubleshooting guide for direction if a problem is discovered during start-up.

MANUFACTURED BY

norweco®

Engineering the future of water
and wastewater treatment.

NORWECO, INC.
NORWALK, OHIO
U.S.A. 44857
www.norweco.com

norweco® **HYDRO-KINETIC**®

WASTEWATER TREATMENT SYSTEM

FINAL INSTRUCTIONS TO THE OWNER

When the initial start-up of the Hydro-Kinetic system has been completed, take a few minutes to review the system and its operation with the owner. Although no owner maintenance is required, several precautions should be taken to insure maximum performance of the system. Emphasize the continued benefits and protection available through the two year limited warranty and prescheduled service inspections which have been included in the purchase of the Hydro-Kinetic system. These instructions, used with a review of the Owner's Manual, will give the owner a basic understanding of the Hydro-Kinetic wastewater treatment system.

PRESCHEDULED SERVICE INSPECTIONS

During the initial two years after installation, service inspections will be made as required by local regulations to insure proper system operation. The effluent will be evaluated for color, turbidity, scum overflow and odor. Written reports on the condition of the equipment and results of the effluent quality inspection will automatically be made to the owner and to the local health department. Costs for travel and labor during this period are included in the purchase price of the Hydro-Kinetic system. If improper system operation cannot be remedied at the time of inspection, the owner shall be notified in writing. If emergency service covered by the warranty is needed during the first two year period, it will also be provided at no additional owner expense.

CONTINUOUS OWNER PROTECTION PROGRAM

At the conclusion of the initial two year period, continued service inspections may be made as required under a Hydro-Kinetic Service Contract available from the licensed distributor for a reasonable charge. Written reports will continue to be made automatically. Costs for travel and labor during service inspections are at no additional charge and emergency service is guaranteed within forty-eight hours. The owner will automatically be mailed a service contract with a letter outlining the advantages of continuing service and a fee quotation before the initial two year period expires.

NO OWNER MAINTENANCE

No owner maintenance is required on the pumps or electrical controls. System operation and individual components will be thoroughly checked by the service technician during each service inspection. The air pump includes impact-resistant rubber diaphragms and valves. The recirculation pump contains moisture resistant windings securely mounted inside an oil-filled, watertight housing for maximum life. The control center has no user-serviceable parts inside and is secured with a tamper evident seal. Disassembly of any component part will void the limited warranty. Instruct the owner to contact the local distributor with questions and service requests.

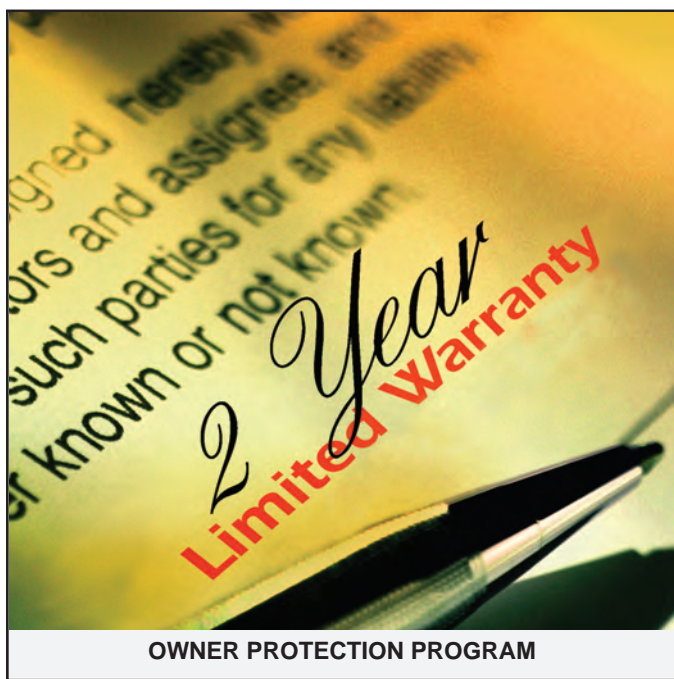

OWNER PROTECTION PROGRAM

TWO YEAR LIMITED WARRANTY

The Hydro-Kinetic air pump, recirculation pump and control center are warranted to be free from defects in material and workmanship under normal use and service for a period of two years from the date of system installation, provided the customer completes and returns the Warranty Registration Card to the factory. Registration is important: if the card is not received, the warranty will be recognized in effect for two years from the date the air pump, recirculation pump and control center were shipped from the factory. To qualify for service under warranty, the owner must not disassemble any component part. The defective component must be returned to the factory by the local distributor. It may not be returned directly to Norweco by the owner. The warranty is limited to the replacement of defective parts and does not cover damage resulting from accident, abuse, improper installation, unauthorized disassembly, faulty wiring or failure to follow operating instructions.

FINAL OWNER INSTRUCTIONS (Cont.)

The owner should be advised to make the following periodic checks of the system to insure that it continues to operate at maximum performance levels:

1. The Service Pro control center should be checked daily. If the red warning light is glowing and the audible alarm sounding, depress the reset button on the control center cover. The light should go off and the audible alarm should be silenced. If the alarms activate again, call the local distributor for service.
2. Check the fresh air openings in each vented cover monthly to make sure the passage of air into the Hydro-Kinetic tank has not been restricted.
3. Inspect the effluent discharge point and ground water relief point monthly to make sure there are no restrictions to the effluent flow.
4. Make sure the pretreatment chamber is inspected at least every three years. Have it pumped only when necessary. See Hydro-Kinetic Tank Pumping instructions to determine when system pumping is required.

FOR BEST RESULTS

Be sure the owner understands the system's capabilities and purpose. Discuss the importance of the following items with the owner to maximize system performance.

Always

1. *Repair any leaking faucets or toilets promptly.*
2. *Discharge only biodegradable wastes into the system.*
3. *Divert down spouts and other surface water away from the system.*
4. *Keep riser covers accessible for service and inspection.*
5. *Consult your Norweco distributor before using enzymes, tank activators or similar additives.*
6. *Call your Norweco distributor if you have problems or questions.*

Never

1. *Connect roofing down spouts, footer drains, sump pump piping or garage and basement floor drains into the sewer line of the Hydro-Kinetic system.*
2. *Allow backwash liquid from a water softener to enter the system.*
3. *Dispose of items such as lint, cooking grease, scouring pads, diapers, sanitary napkins, cotton balls, cotton swabs, cleaning rags, dental floss, strings, cigarette filters, rubber or plastic products, paints and thinning agents, drain cleaners, gasoline, motor oil or other harsh chemicals in the domestic wastewater plumbing.*
4. *Dispose of disinfectants, pesticides, poisons or toxic materials down your drain.*
5. *Use the power supply to the air pump or recirculation pump as a service receptacle for lawn and garden tools.*
6. *Interrupt power to the Hydro-Kinetic control center, even during extended periods of non-use. If you anticipate a long term vacancy, contact the local distributor for proper procedures.*

BEFORE LEAVING THE SITE

Remind the owner that the limited Warranty Registration Card must be filled in and mailed as soon as possible. Explain that your company's telephone number is found on the Service Pro control center. Offer to remove and return the Warranty Registration Card for the owner. Have them sign the card and return it to your office to be mailed to Norweco. As you leave, remind the owner to call your office if any questions arise.

PROGRESS THROUGH

norweco[®]
www.norweco.com

SERVICE SINCE 1906

norweco® **HYDRO-KINETIC**®

WASTEWATER TREATMENT SYSTEM

SERVICE PROGRAM AND RECORDKEEPING

Complete and detailed installation and service records must be kept on each Hydro-Kinetic system. Properly maintained records will enable you to determine, at a glance, the history and condition of each system sold. Keep all installation and service records filed as outlined herein so that you will have immediate access to this information. Following these procedures allows efficient organization of service inspection dates and service policy mailings. Their use will enable you to provide complete and professional service to your Hydro-Kinetic customers.

INITIAL ORDER RECORDS

When a Hydro-Kinetic system order is received, the following information should be recorded on your delivery slip: customer's name, address and telephone number, equipment ordered (including system model number and optional equipment such as ultraviolet disinfection system, directions to the site, delivery date and time requested. Give this information to the dispatcher for delivery truck scheduling.

ASSIGN COMPONENTS FROM STOCK

To begin processing the order, select an equipment package from your stock. The equipment package includes an air pump, a recirculation pump and control center with serial numbers that have been recorded at the factory as a matched set. These components should be installed together for proper recordkeeping. Attached to the air pump is a copy of the three-part warranty registration card and a red warning tag. Make sure that the model number and serial number on the outside of the air pump shipping carton matches the air pump nameplate and all three sections of the registration card. Give the control center and enclosed literature packet to the tank delivery driver.

Do not remove the air pump, recirculation pump or plumbing from the original equipment package shipping carton. Close the carton and identify it on the outside with the name and address of your customer so that the matching air pump, recirculation pump and control center will be installed. Store the equipment package carton in your plant until the customer requests installation and start-up.

TANK INSTALLATION RECORDS

When the Hydro-Kinetic tank and controls are installed, the contractor or owner should sign an itemized delivery slip. Tear off the bottom portion of the three-part card attached to the air pump in the equipment package carton. One service and warranty record card should be filled out with the tank setting date, owner's name, address and telephone number, contractor's name, directions to the jobsite, a

description of the installation, optional equipment installed and location of the tank and control center. Other service and warranty record cards for the same system should be attached to the completed card. All service and warranty record cards should be returned to your office and kept until the system is ready for start-up. Leave the remaining two portions of the three-part card intact and store them with the Hydro-Kinetic Owner's Manual.

RECORDS OF SYSTEM START-UP

When air pump and recirculation pump installation is scheduled, give all service and warranty record cards to your installer. These cards contain all information needed to perform start-up services. The date of air pump installation and start-up should be filled in and these cards returned to the office when the air pump and recirculation pump have been installed.

HYDRO-KINETIC CUSTOMER MASTER FILE

When the Hydro-Kinetic system start-up is complete, transfer the owner's name, address, telephone number, system model number, serial number for the air pump, serial number for the recirculation pump, and system installation date from the service and warranty record card to a standard 4 x 6 file card. Place all cards alphabetically by owner name in the Hydro-Kinetic master file. The file should contain one card for each Hydro-Kinetic system installation. It must be updated whenever an exchange air pump and/or recirculation pump is installed or when a change in system ownership occurs.

HYDRO-KINETIC SERVICE FILE

File each original service and warranty record card in the Hydro-Kinetic service file. The service file should be set up on the first month you begin to install and start-up Hydro-Kinetic systems. Make a divider tab which has visible the number "1" on it. File the service and warranty record card for each system placed into operation this month ahead of this divider "1" tab. On the first day of the second month, make a new divider tab titled "2." File this

SERVICE PROGRAM AND RECORDKEEPING (Cont.)

divider behind the first one and move all registration cards filed last month to a new position in front of divider #2. Place all record cards for installations started-up in this, your second month, ahead of divider #1. On the first day of each succeeding month, a new divider must be placed at the end of the file, then all cards moved back one divider, then all new installation cards for the current month filed ahead of divider #1. Do not file current installation cards prior to advancing the previous month's cards.

SCHEDULING SERVICE INSPECTIONS

Service inspections are to be completed for the first two years after the system has been installed. They are scheduled after twelve and twenty-four months, or as required by local governing regulations. To determine which systems are due inspections each month, update the Hydro-Kinetic service file with a new month divider on the first day of the month and remove all cards from behind divider tabs 12 and 24. Fill out one three-part service inspection record card for each system with system model number, air pump and recirculation pump serial numbers, county, owner's name, address and directions to the site. Be sure this information is duplicated on all three sections of the service inspection record card. The other side of the card will be filled out by the service technician at the site. If this is to be the 24th month inspection and the system owner has not renewed and returned a service contract, check the box on all three portions of the card indicating that the service policy on this system has expired. Give the service inspection record cards to the service manager.

Your service technicians must fill in the remaining items on both sides of each card as they make the inspections. The top portion is torn off and left with the system owner. The lower two portions are returned to the office. The middle portion of the card is for health department notification. Most health departments prefer that these cards are collected by the distributor and mailed in monthly rather than individually.

The bottom portion of the service card is retained for your records. It should be filed behind the service and warranty record card for that installation. This allows all records of service inspections for each installation to be filed together. As you file the service inspection cards, you should update the service and warranty record card with the date and results of your inspection.

EMERGENCY SERVICE CALLS

Occasionally you may be asked to service a Hydro-Kinetic system in advance of its next prescheduled inspection. When the request for service is taken, look up the service and warranty record card in the service file. Use it to prepare a new three-part service inspection card and check the box for "Special Service Call." This service inspection card must be completed by your service technician and

returned to your office. When it is returned, the check for "Special Service Call" signifies that the service and warranty record card for this installation probably will not be found following a divider tab scheduled for service this month. When the record card is located, fill in the service call date for the next prescheduled inspection and file the service card in chronological order behind the service and warranty record card. When the next prescheduled inspection for this system is due, service will be considered complete.

MAILING SERVICE POLICIES

Initial Hydro-Kinetic system service is in effect for the first twenty-four months of system operation. After that time the owner is invited to continue routine service for their Hydro-Kinetic system on an annual basis. Service contracts should be mailed in the twenty-second month of system operation. After updating the service file at the beginning of each month, remove all service and warranty record cards from behind divider tab #22 and mail a service contract and cover letter to each system owner. Follow-up



each mailing to owners who have not responded to your 22nd month notice by re-mailing to all service and warranty record cards behind divider tab #23 whose contracts have not been renewed. Record the dates of these mailings on the registration card.

RENEWED SERVICE POLICIES

MANUFACTURED BY

norweco[®]

Engineering the future of water
and wastewater treatment.

NORWECO, INC.
NORWALK, OHIO
U.S.A. 44857
www.norweco.com

HYDRO-KINETIC®

WASTEWATER TREATMENT SYSTEM

SERVICE PROGRAM AND RECORDKEEPING (Cont.)

If an executed service contract and fee are received by the end of the two year service period, the service and warranty record card (followed by the completed service inspection cards) is retained in the service file. Service policy inspections after the initial two year program are performed in the same fashion as initial inspections. Cards each month from behind divider tabs 12 and 24 and from behind tabs which are multiples of twelve: 36, 48, 60, 72, etc. are used to schedule routine service for the month. Fill out three-part service cards for each installation and continue to file completed service inspection cards chronologically behind individual service and warranty record cards. Remember to update the service and warranty record cards for each installation as service contract inspections are performed.

Continued service policies are renewed annually. Renewal service contracts should automatically be mailed in their tenth month. They should be done monthly when initial service contracts are mailed to owners in the twenty-second month of Hydro-Kinetic system operation. In any given month, service contracts due to expire in two months will be located behind divider tabs #34, 46, 58 and so forth. Second mailings may be made from cards located behind divider tabs #35, 47, 59, etc. excluding those whose renewal contracts have been returned.

Executed service contracts should be filed alphabetically by owner's name in a separate file. Multiple copies for owners who consistently renew their contracts should be attached to each other and organized chronologically.

LAPSED SERVICE CONTRACT RENEWALS

DEAR OWNER:

HYDRO-KINETIC®
WASTEWATER TREATMENT SYSTEM

Dear Owner:

When you purchased your Norweco Hydro-Kinetic wastewater treatment system, a two year limited warranty was included in the purchase price. The purchase also provided for a two year service inspection program at no additional cost to you.

We are pleased to be able to offer a continuing service program similar to the one originally included with your system, now that your initial service program and limited warranty have expired. Our continuing policy ranges of the way from routine inspections and emergency service to owner limitation on labor costs. We have enclosed a complete copy of our renewable service contract, with costs for your system, for your review and consideration.

We would be happy to answer any questions regarding the renewable service program or any other questions you may have regarding operation and maintenance of your Hydro-Kinetic wastewater treatment system. Please take the time to review and consider the advantages of the service contract we have enclosed. As in the past, our company also continues to offer service and repair for systems on an "as needed" basis in the area we serve. Thank you.

Sincerely yours,
Your Local Licensed Norweco Distributor

NORWECO, INC. - NORWALK, OHIO - USA

norweco
HYDRO-KINETIC®
SERVICE CONTRACT

OWNER'S NAME: _____

ADDRESS: _____

TELEPHONE NO. () _____

EFFECTIVE DATE: _____ 20

EXPIRATION DATE: _____ 20

SYSTEM INSTALLED ON: _____ 20

This one year service contract for the Hydro-Kinetic wastewater treatment system located at the site described above is intended to enable the owner to economically obtain regular service inspections for the Hydro-Kinetic unit, as well as an out-of-warranty emergency service. This plan is required by the manufacturer. When this contract is in force, the owner will not be charged for any routine service, but under the terms of this service agreement, a technician will regularly inspect the plan as required by the local governing authority. The contract will remain in effect for a period of one year, as specified in the table with a 48-hour period. The contract and fee are to be returned to the distributor at the time of the effective and expiration dates listed above.

PLEASE CONSIDER

From time to time an owner may wish to renew a service contract which had been permitted to lapse. When the executed contract and fee are received, remove the service and warranty record card, with all service cards, from the alphabetical master file. Only the 4 x 6 master card should remain. Refile all other cards in the active service file behind the divider tab it would have been found in, according to system age as if the service policy had been continuously in force. This filing order will allow you to use the procedures already established for service scheduling and renewal policy mailings.

INSTALLATION OF REPLACEMENT AIR PUMP OR RECIRCULATION PUMP

When an owner uses the two year limited warranty to receive a new air pump or new recirculation pump for their Hydro-Kinetic system, the two year limited warranty and the two year initial service program do not begin again. No service is performed unless a service contract is in effect. When the replacement air pump or recirculation pump is installed, the new serial number should be recorded on the supplemental service record section of the service and warranty record card in the Hydro-Kinetic customer master file or service file, whichever is appropriate. Note on the existing card the new air pump or new recirculation pump installation date. Record the replacement pump serial number and installation date on the 4 x 6 card in the alphabetical master file. It is important that the original Hydro-Kinetic system installation information from the service and warranty record cards be retained for installations with replacement pumps, because future determinations of pump warranty will be based upon the original system start-up date.

INACTIVE HYDRO-KINETIC INSTALLATIONS

If an executed service contract and fee are not returned by the end of the twenty-fourth month of system operation, the installation is considered inactive. Its service and warranty record cards and all service cards must be removed from the active service file. They are refiled behind the alphabetical listing card in the Hydro-Kinetic customer master file. Inactive cards remain in this file unless the owner executes a new service contract at a later date. All renewed service contract holders whose contracts lapse must also have their cards transferred to the alphabetical file. If an owner requests service on an out-of-warranty system, service should be performed on a time and materials basis. A three-part service card must be completed as usual and the distributor's copy should be returned to the office and filed in order behind the last service card for the installation.

THREE SIMPLE FILES PROVIDE AUTOMATIC SERVICE SCHEDULING

Detailed and accurate record keeping guarantees efficient service performance, reduced man-hours and increased profits.

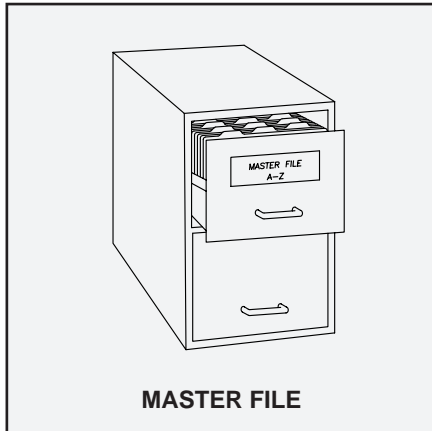

MASTER FILE

Contains a 4 x 6 file card for each installation which:

- Lists owner's name, address and telephone number
- Lists system installation date, model number and serial numbers
- Is updated when ownership changes
- Is updated when a replacement air pump or recirculation pump is installed
- Is followed by service and warranty record card and all service inspection cards for inactive installations

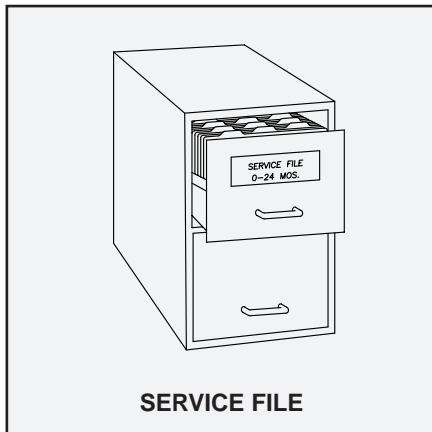

SERVICE FILE

Contains monthly divider tabs used to:

- File service and warranty record cards by month of installation for in-warranty components
- File all service and warranty record cards for out-of-warranty systems with continued service policies



SERVICE POLICY FILE

Contains all executed service contracts for each Hydro-Kinetic installation filed:

- In alphabetical order by owner's name
- In chronological order by contract effective date

PROGRESS THROUGH

norweco[®]
www.norweco.com

SERVICE SINCE 1906

***norweco*® HYDRO-KINETIC®**

WASTEWATER TREATMENT SYSTEM HYDRO-KINETIC® SYSTEM AND CONTROL CENTER SERVICE

To maximize owner protection, the Hydro-Kinetic wastewater treatment system is backed by a two year limited warranty on system components. The initial selling price includes prescheduled service inspections, as required by your local governing regulations, which cover the first two years of system operation. These service inspections should completely familiarize the owner with the Hydro-Kinetic wastewater treatment system and answer any questions that arise. Carefully check all component parts of the Hydro-Kinetic system to insure proper operation and overall wastewater treatment quality. Regular service inspections by qualified technicians establish an excellent relationship with the owner as well as with local health officials. They must be performed faithfully to keep you up-to-date on the performance of each Hydro-Kinetic system you have installed.

While making service inspections during the initial two year period, be sure to explain to the owner that they are being performed at no charge and that the same coverage can be renewed on a continuing basis at a nominal charge following the initial two year program. Point out the advantages of continuous protection with the service contract. Be sure to remember that service contract sales have advantages for the distributor as well. They result in more efficient service inspection scheduling with more actual "service time" and less "travel time" per day. These savings can be passed on to the owner through more attractive renewal contract fees in future years.

All of the equipment and tools needed for Hydro-Kinetic system service work are contained in the Hydro-Kinetic Tool Kaddy. You will also need exchange air pumps and recirculation pumps.

HYDRO-KINETIC SYSTEM SERVICE PROVIDES CONTINUOUS OWNER PROTECTION WITH THESE ADVANTAGES

- Travel and labor costs during service inspections are provided at no charge to the owner.
- Special service calls that may be necessary during the program are performed at no charge to the owner.
- Owner's investment, property and the environment are fully protected.
- Guaranteed response to emergency service requests is made within forty-eight hours.
- Local health department is automatically notified of system condition by the distributor.
- Owner has an up-to-date, written record of the condition of the air pump, recirculation pump, control center and Hydro-Kinetic filter.
- Owner is continuously informed of the treatment quality provided by the system.
- Routine maintenance is performed by factory-trained service technicians; no owner maintenance is required.
- Owner can expect maximum air pump life and minimal power consumption costs due to regular, qualified service visits.

These instructions are designed to cover the important points of Hydro-Kinetic system operation which should be checked during each service inspection. They have been arranged in normal service order to assure that you make the most efficient use of your time. While a visual check is normally sufficient to be certain that each item is in proper working order, several items listed in this manual are indications of potential problems. If anything unusual is encountered, refer to the Hydro-Kinetic Troubleshooting Guide.

NORWECO PRESCHEDULED SERVICE INSPECTIONS (Cont.)

Before you leave your plant

- Be sure you have a complete list of service needs in the area you are going to work.
- Check to see that you have detailed directions to each installation.
- Be sure your service vehicle is fully stocked.

When you arrive at the site

- Meet the owner. Introduce yourself and present your business card.
- Explain the service inspection program and outline what you will do. Mention that your services are at no charge.
- Ask for permission to inspect the Service Pro control center and Hydro-Kinetic tankage.
- Make sure the owner has a copy of the Owner's Manual, serial number tag and previous Service Inspection Record Cards.
- Suggest that the owner record the information from the Service Inspection Record Card in the Supplemental Service Record Section of the Owner's Manual.
- Ask if there are any questions concerning the system or its operation.

CONTROL CENTER SERVICE

CAUTION: If your visual inspection of the Service Pro control center reveals a problem, be sure to shut off the appropriate circuit breaker in the main service panel - then test all circuits with the electrical multi-meter to be sure they are de-energized before proceeding.

1. If there is no evidence of an electrical problem, check the main service panel to see that the circuit breaker for each Hydro-Kinetic system is turned on.
2. Make sure the panel is turned on. If there are any alarm lights activated, refer to the Service Pro Model 801P Quick Start Guide for further diagnostic instructions.
3. See that your company's identification label is affixed to the Service Pro control center and is legible. Replace the label if necessary.
4. Make sure that the air pump serial number tag is attached to the air pump or has been stored by the owner in a secure location. If it has been misplaced, provide a new one and fill in the appropriate information.
5. See that the Owner's Manual has been stored by the owner in a secure location. If it has been misplaced, supply the owner with a new one.
6. Inspect the wiring from the control center to the air pump and recirculation pump, as far as it is visible, and notify the owner if you see any damaged areas.
7. As you leave, make sure the Service Pro control center is turned on and there are no active alarms. Secure the Service Pro control center with a new tamper evident seal.
8. Make appropriate notations on the condition of the control center on the Service Inspection Record Card.

MANUFACTURED BY

norweco[®]

Engineering the future of water
and wastewater treatment.

**NORWECO, INC.
NORWALK, OHIO
U.S.A. 44857
www.norweco.com**

norweco® HYDRO-KINETIC®

WASTEWATER TREATMENT SYSTEM

AIR DELIVERY AND RECIRCULATION SYSTEM SERVICE

The Model A100 air pump, diffuser assembly, Model SD103 recirculation pump and mixing bar assembly have been specifically designed for use in the Hydro-Kinetic system. The air pump and diffuser provide maximum air introduction to the aeration chamber, while the recirculation pump and mixing bar provide thorough mixing of the anoxic chamber contents to assure reliable, economical wastewater treatment. The air pump can be remotely mounted or installed in the access riser above the aeration chamber. Only the plastic diffuser assembly and air piping are submerged. The recirculation pump is installed in the bottom of the clarification chamber. The pump transfers a portion of the wastewater back to the anoxic chamber through a prefabricated mixing bar assembly. Unauthorized tampering or repair of the air pump or recirculation pump will void the warranty.

CAUTION: Any time an air pump, recirculation pump or test equipment is connected or disconnected, first shut "off" the power switch in the control center. Failure to do so could result in personal injury or equipment damage.

AIR DELIVERY SYSTEM SERVICE

1. As you approach the Hydro-Kinetic tank, listen for excessive noise before removing the vented cover.
2. Remove the vented access cover located above the aeration chamber and place it aside. The air pump should be operating normally.
3. Manually check the air pump for excessive vibration. Inspect the vent cap and air pump for objects, plants, insects or debris that could impede the air intake. Remove these items if present.
4. Check the aeration chamber for odor. A musty odor indicates the presence of aerobic conditions essential for good treatment. A septic odor indicates inadequate aeration, suggesting that the passage of air into the tank contents has been restricted.
5. Check the aeration chamber and insure the diffuser assembly is creating a rolling motion of the chamber contents. If a rolling motion is not visible, verify the air pump is operating properly.
6. Move the power switch in the control center to the "off" position. Inspect the outside of the electrical connector assembly for worn spots. Uncouple the connector and check for any evidence of moisture inside. Secure the closure cap over the female half of the connector to keep it clean and dry while you work.
7. Unscrew the diffuser drop pipe assembly from the air pump at the union and remove the air pump from the mounting riser. Place the air pump on the vented cover.
8. Remove the air pump concrete mounting pad.
9. Within 2-3 minutes after turning off the air pump, perform a settleable solids test of the aeration chamber contents. Refer to Hydro-Kinetic Tank Pumping instructions for details.
10. Check the power cord from the moisture-resistant electrical connector to the air pump. Be sure it is free of nicks or worn spots.
11. Check to see if there is a water mark on the outside of the air pump and notify the owner if one is found. A high water mark indicates a problem in the effluent disposal line, disposal field or elsewhere in the installation. If left uncorrected, wastewater could back up into the tank, void the warranty and eventually flood the facility.
12. Check the air filter and clean or replace as required.
13. Remove and clean diffuser assembly if necessary. Use the hook attachment on the universal tool to guide the diffuser bar out of the aeration chamber riser.
14. Check the aeration chamber for the presence of non-biodegradable materials, paper, mop fibers, hair, grease or oil. A significant accumulation of these materials in the aeration chamber indicates the pretreatment chamber should be evaluated. Refer to Hydro-Kinetic Tank Pumping instructions for details.

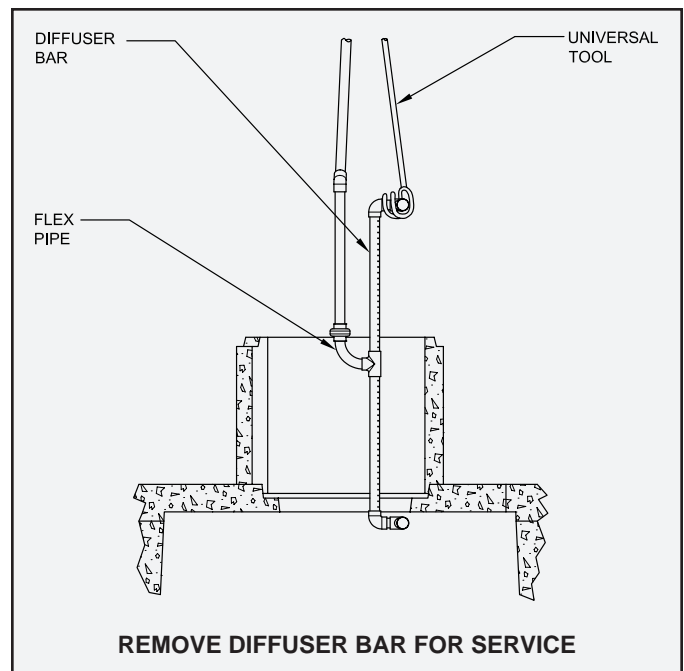

AIR DELIVERY AND RECIRCULATION SYSTEM SERVICE (Cont.)

15. Inspect the underground power cable in the air pump mounting riser for breaks or scars in the insulation. Examine the inside of the riser casting for evidence of ground water entry.
16. Carefully reinstall the air pump on the concrete mounting pad in the aeration chamber riser.
17. Using a multi-meter, check the voltage at the electrical connector. The meter should read 115 volts \pm 5%. Record the voltage on the Service Inspection Card.
18. Wipe the electrical connector with a clean, dry cloth to remove moisture or dirt accumulated during service. Plug the electrical test pigtail in between the male and female electrical connectors and check the amperage of the newly serviced air pump. The air pump should not draw more than 1 amp. Record the amperage on the Service Inspection Card.
19. Reinstall the access cover on the aeration chamber mounting riser.

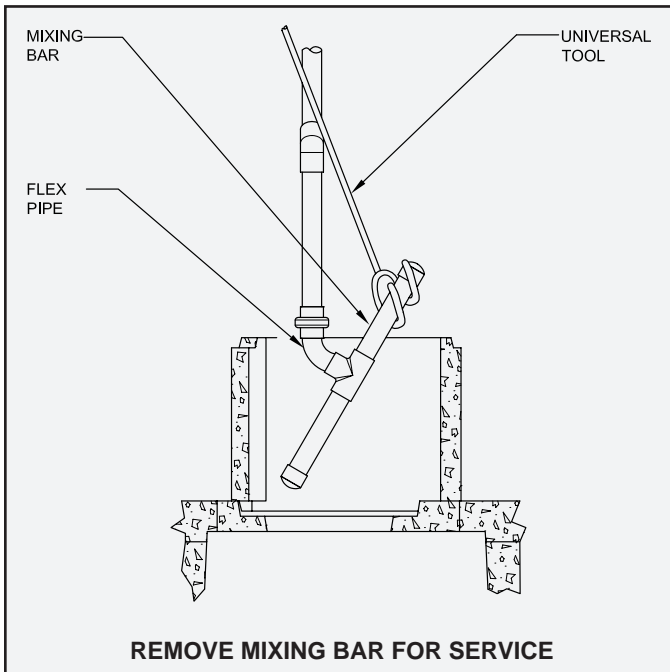

RECIRCULATION SYSTEM SERVICE

1. Remove the anoxic chamber access cover and place it aside. Check to insure the mixing bar is operational.
2. If the mixing bar requires service, use the hook attachment on the universal tool to guide the mixing bar out of the riser.
3. Remove the clarification chamber access cover and place it aside. The recirculation pump should be operating normally. The recirculation pump operates on a pre-programmed on/off cycle, so press the reset button if necessary to verify operation.
4. Inspect the flow equalization device. Rinse the design flow, sustained flow and peak flow ports with a garden hose and insure they are free of debris. Clean the flow ports with a soft-bristled brush if necessary.
5. Check the surface of the clarification chamber for grease or biologically untreatable material. A

significant accumulation of these materials indicates the pretreatment chamber should be evaluated to determine if pumping is required. With the air pump running, use the hopper scraping tool to gently scrape all areas of the clarification chamber hopper. Scrape all the way down to the bottom of the chamber. Then scrape the small flat area at the bottom of the hopper, pushing toward the aeration chamber as far as possible.

6. If necessary, use water to wash away any sludge from the inside of the system riser casting, access cover and surrounding grass or landscaping.
7. Note the liquid level in the clarification chamber. If the liquid level is above the flow line of the outlet coupling, consult the troubleshooting guide to determine if there is a problem with drainage. Improper drainage will lead to flooding of the Hydro-Kinetic wastewater treatment system and must be reported to the owner. Examine the inside of the access riser for evidence of surface water entry.
8. Examine the condition of the Hydro-Kinetic tank outlet coupling. Any debris that has accumulated inside of the tank outlet coupling must be removed to insure proper system operation.
9. Reinstall the clarification chamber access cover.
10. Make the appropriate notations regarding the air pump, recirculation pump, flow equalization device, the results of the settleable solids test and related items on the Service Inspection Card.
11. Proceed with Hydro-Kinetic filter service as outlined in Hydro-Kinetic Filter and Media Service instructions. When the service is complete, return the power switch in the control center to the "on" position. Close the cover of the control center enclosure and secure it with a new tamper evident seal.

IF AN AIR PUMP OR RECIRCULATION PUMP MUST BE REPLACED

The service technician should be able to restore most installations to full operation during the initial service call. If the air pump or recirculation pump is no longer eligible for the two year limited warranty, the air pump or recirculation pump should be removed and replaced with an exchange unit from your rotating stock. This will become the permanent air pump or recirculation pump in service at the facility and your company's service records should be updated to reflect the new air pump or recirculation pump serial number. If the serial number portion of the Warranty Registration Card is still attached to the air pump, be sure to fill in the new serial number for the owner.

MANUFACTURED BY

norweco[®]

*Engineering the future of water
and wastewater treatment.*

**NORWECO, INC.
NORWALK, OHIO
U.S.A. 44857**

www.norweco.com

norweco® **HYDRO-KINETIC**®

WASTEWATER TREATMENT SYSTEM

HYDRO-KINETIC BIO-FILM REACTOR SERVICE

Check operation of the Service Pro control center and complete all Hydro-Kinetic Air Delivery and Recirculation System Service instructions before proceeding with Hydro-Kinetic Bio-Film Reactor service. The Bio-Film Reactor provides final treatment of the system effluent to a near pristine state. In order to insure this high quality effluent, it is essential that the settled solids in the Bio-Film Reactor are pumped to the pretreatment chamber during system service.

CAUTION: *Anytime an air pump, recirculation pump or service pump is connected or disconnected, first shut off the power switch in the control center. Failure to do so could result in personal injury or equipment damage.*

EQUIPMENT REQUIRED FROM THE TOOL KADDY

- water hose and spray nozzle
- service pump and hose
- outlet blocking tool
- rubber gloves
- safety face shield or goggles

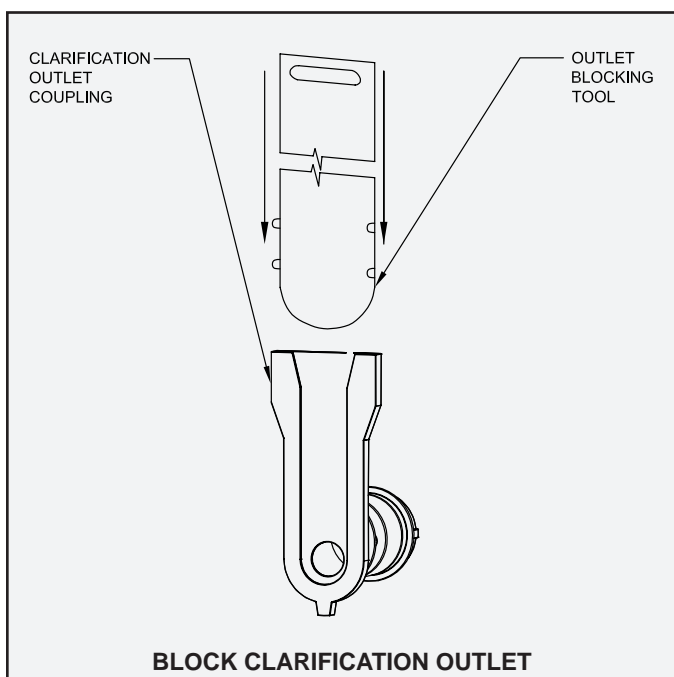

A fresh water supply is required for cleaning and servicing the Hydro-Kinetic Bio-Film Reactor.

1. Remove the access covers from the pretreatment chamber, clarification chamber and Bio-Film Reactor. Check the condition of the Bio-Film Reactor and the liquids in the tank for color and odor. Note the condition of the system on the Service Inspection Card.
2. With the flow equalization device in place, install the outlet blocking tool in the clarifier outlet coupling prior to pumping the Bio-Film Reactor. This will prevent loss of liquid from the upstream treatment tank.

3. Place the intake of the service pump at the bottom of the influent chamber. Place the opposite end of the hose into the pretreatment chamber opening of the upstream system. Pump the contents from the bottom of the Bio-Film Reactor until the accumulated solids are completely withdrawn and the water level is below the bottom of the Reactor Elements. Approximately 150 gallons will be removed.
4. Use a water hose and spray nozzle to rinse off the Reactor Elements and attached growth media. Continue spraying until all sludge and wastewater have been flushed from the media. Rinse away debris that has accumulated on the effluent chamber walls.
5. If necessary, use water to wash away any debris from the inside of the system mounting riser, access cover and surrounding grass or landscaping.
6. Reinstall the pretreatment chamber and Bio-Film Reactor access covers. Clean and store all tools.
7. Remove the outlet blocking tool and allow the filter to refill to normal operating level. Be sure to never leave the Bio-Film Reactor empty after pumping.
8. When the service is complete, return the power switch in the control center to the "on" position. Close the cover of the control center enclosure and secure it with a new tamper evident seal.

REACTOR ELEMENT REMOVAL

In the unlikely event that the Reactor Elements cannot be adequately cleaned using normal maintenance spraying, removal from the tank may become necessary.

1. Excavate to the top of the Bio-Film Reactor tank to expose the rectangular access openings. Remove the access openings and set them aside.
2. Remove the outlet tee. It is not glued in place.
3. Use the disassembly tool to turn the locking mechanisms inward on the Reactor Elements until they clear the locking ledge.
4. Thread the removal hook tool to the shaft of your universal tool. Insert the two hooks of the tool in the fourth square opening from the side wall of the tank.

HYDRO-KINETIC FILTER AND MEDIA SERVICE (Cont.)

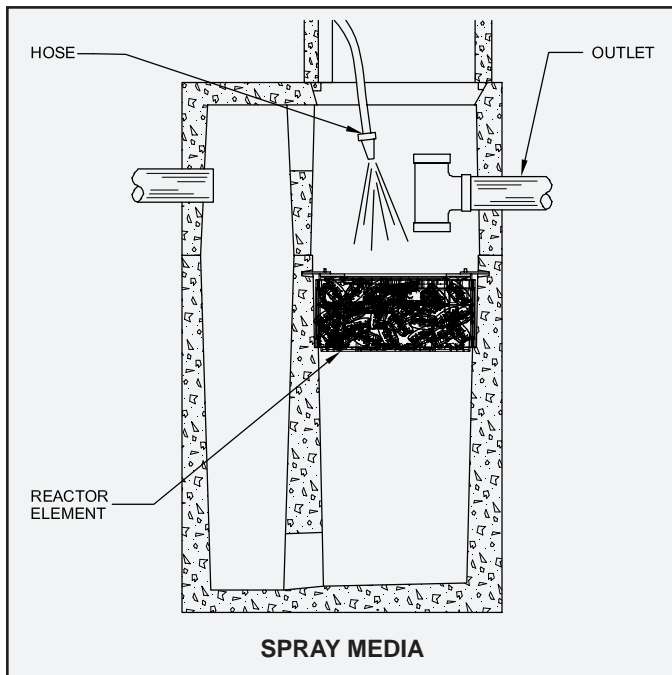

5. Lift the Reactor Element from its position by imparting an upward force. Remove the remaining reactor from the tank using the same method through the opposite access opening.
6. Place the Reactor Elements in the service bag provided with your Tool Kaddy to return to your shop for cleaning. Install new or refurbished Reactor Elements in the Hydro-Kinetic Bio-Film Reactor.
7. Using the disassembly tool, turn the locking mechanisms outward on both Reactor Elements until they are secure under the locking ledge.
8. Reinstall the outlet tee. Replace the rectangular access covers on the tank top and backfill the excavation. Be sure to slope grade away from the riser.

EFFLUENT DISPOSAL SYSTEM CHECK

1. Determine if the effluent from the system is being carried to an outlet for surface and/or subsurface discharge, or if it is being disposed of onlot. Inspect the condition of the effluent disposal system and make appropriate notations on the Service Inspection Card.
2. Although the system effluent may be discharged and disposed of in several acceptable fashions, there should always be a ground water relief point installed in the effluent line. It should be located at a point no higher than the outlet invert of the tank. It will prevent flooding in cases where the disposal line is submerged or saturated with ground water. Locate the ground water relief point and be sure that it is free of obstructions.
3. Locate the point of discharge closest to the system outlet. A free-falling "grab" sample of effluent can be collected after the point of discharge has been thoroughly cleaned. Take note of effluent color, odor and the presence or absence of suspended particles. Accumulation of mud can be a sign of a crushed or broken effluent line and should be reported to the owner.

NOTE: An effluent "grab" sample allows a visual assessment and should only be used in conjunction with routine service and/or troubleshooting procedures to accurately evaluate system operation. A "composite" sample, collected over 24 hours of system operation, preserved and transported using USEPA established procedures, is necessary if laboratory analysis of the effluent is to be performed. Laboratory analysis of an effluent "grab" sample can lead to misleading conclusions about system operation and should not be conducted. For further information regarding proper evaluation techniques for sampling onsite systems, refer to the Norweco Technical Bulletin EFFLUENT SAMPLING TECHNIQUES FOR RESIDENTIAL TREATMENT SYSTEMS.

4. Make appropriate notations on the condition of the plant effluent and disposal system on the Service Inspection Card.

BEFORE YOU LEAVE THE FACILITY...

1. Make sure that both sides of all three Service Inspection Cards are properly and completely filled out, including any specific notes or special services that your inspection indicates are needed.
2. Leave the top section of the Service Inspection Card with the owner and provide a brief verbal explanation of the condition of the system. Advise when to expect your next routine visit and provide your business card with office phone number, should the owner have any questions.
3. Point out the advantages of a continued service policy if the current Hydro-Kinetic system service policy is nearing expiration.
4. Explain that the recirculation pump is set to operate on a time cycle and should not be turned off even during extended periods of non-use. Explain that the control center contains no user-serviceable parts and that the cover is secured with a tamper evident seal for owner protection and protection of component parts.
5. Review the operation of the red warning light and audible alarm on the Service Pro control center with the owner. Inform the owner that the control center should be checked daily to insure proper system operation. Explain that if the light glows and the alarm sounds, it could be due to temporary high water or electrical power fluctuation and that the reset button should be pushed to see if normal operation is resumed before requesting service. If the owner is not home, leave the top section of the service card at the owner's door.

MANUFACTURED BY

norweco[®]

Engineering the future of water
and wastewater treatment.

NORWECO, INC.
NORWALK, OHIO
U.S.A. 44857
www.norweco.com

norweco® **HYDRO-KINETIC**®

WASTEWATER TREATMENT SYSTEM

AIR PUMP REPAIR KIT INSTRUCTIONS

The air pump repair kit is provided so that repair of the Model A100 air pump may be accomplished economically if required. Air pump repair should be done only by a factory-trained technician, and should be performed at your place of business rather than at the installation site. Active systems require an air pump at all times and should be loaned a spare during the pump repair period. Replacement of a properly functioning air pump will not improve operational performance.

The air pump replacement kit contains the following items to be used during replacement:

- Two diaphragms
- Four flapper valves
- Four plastic slip washers
- One bottom pressure chamber gasket

The following equipment is required:

- Phillips head screw driver
- Small adjustable wrench
- Clean working space
- Soap and a clean water source

REPLACEMENT DIAPHRAGM INSTRUCTIONS

1. Disconnect the air pump from the AC receptacle and from plumbing. **CAUTION: Always unplug the unit from its power source before it is removed or disassembled for service.**
2. Remove the pump from the riser and relocate to an uncluttered workspace with access to clean water.
3. Remove the top hand screw and cover from the air pump. Clean the inlet filter and reinstall.

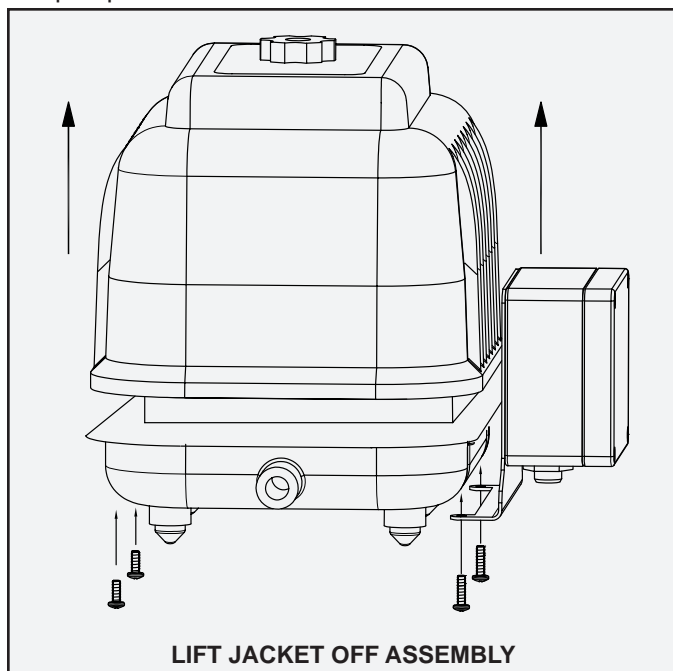

4. Remove the four screws located along the bottom of the outer jacket. Remove the pressure switch enclosure and lift the outer jacket straight off the assembly. Set the screws aside. The pump motor can remain fastened to the base plate during service.

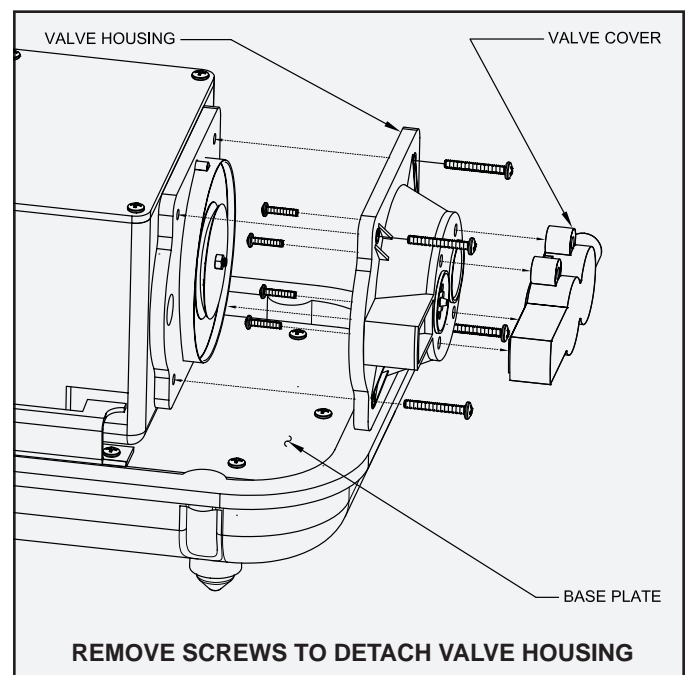

5. Detach the hoses on both sides by squeezing the spring clamps and gently pulling the hose off of the fitting. Remove the four corner screws from each valve housing to remove the assemblies. Use care to insure the screw heads are not stripped. Set the screws aside.

AIR PUMP REPAIR KIT INSTRUCTIONS (Cont.)

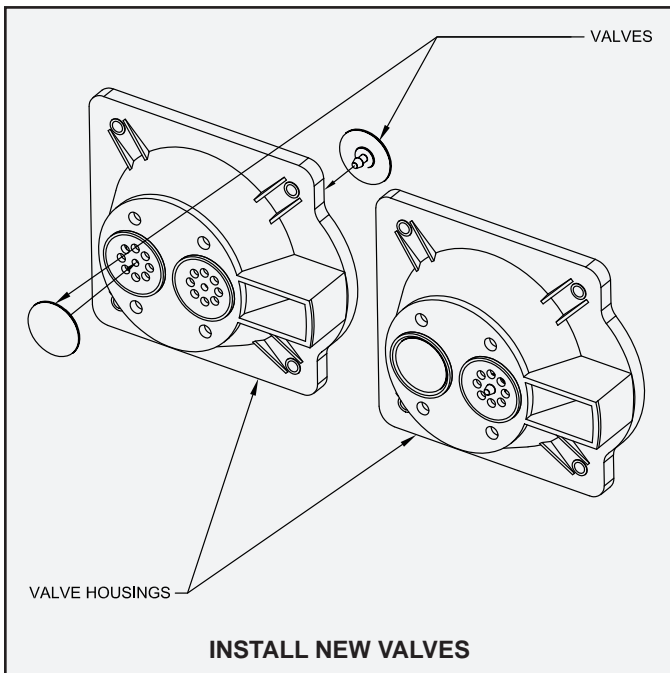

6. Once the valve housings have been detached, open them by removing the four internal screws and removing the valve covers. Remove the old valves and clean the housings. Insert the tabs of the new valves and pull through. Be sure to maintain the original orientation of each valve. Reinstall the screws of each valve cover and set aside.
7. Remove the hex nut and washer from one end of the armature and set aside. Remove the diaphragm retainer, first slip washer, diaphragm and second slip washer. If the white motor shaft cap is removed, simply push it back on making sure that the slots match those of the armature. Discard the old diaphragm and slip washers. Clean the armature assembly with a damp rag.

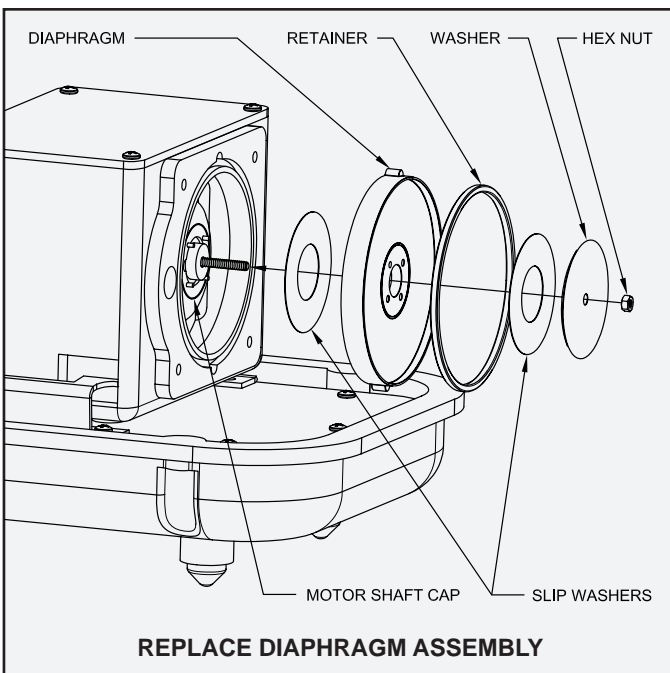

8. Install one new slip washer onto the motor shaft cap. Install the diaphragm into the plastic diaphragm housing making sure the tabs are aligned with slots in housing. Push the retainer ring into the diaphragm to lock it in place. Install the outer slip washer followed by the convex metal washer and hex nut. The outermost slip washer must be held in place until the hex nut is tightened so it remains centered. Repeat steps 7 and 8 on the other side of the armature. Reattach the valve housings to the diaphragm housing and clip the spring clamp on the hoses back into place.

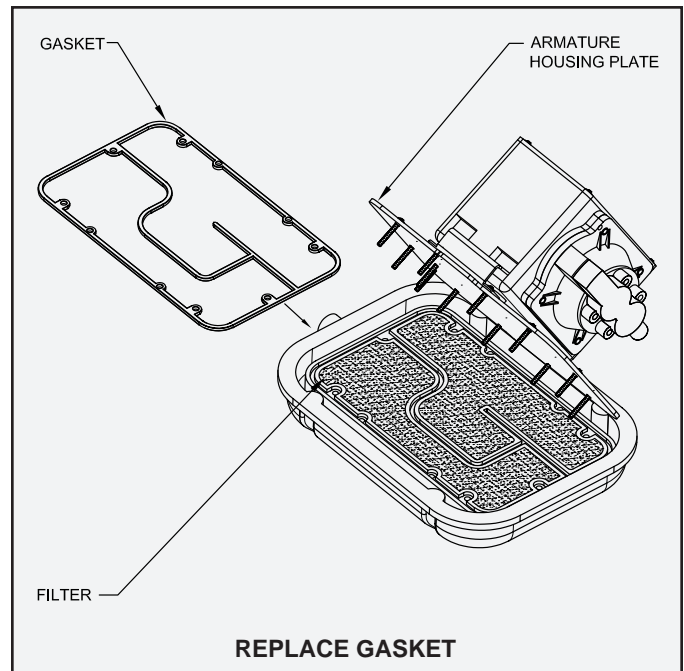

9. Remove the 10 screws holding the base plate to the base of the air pump. This does not include the screw which holds the power wire clamp but does include the green ground wire screw. Lift the assembly around the side of the power cord. Remove and replace the exposed bottom gasket. Remove the filter element. Clean and dry the filter and replace in the base in the original orientation.
10. With the gasket and filter in place, reattach the base plate to air pump base. Replace the top of the compressor housing on the bottom and mount the switch box using the four screws.
11. Reinstall the air pump in the aeration chamber riser and restore power. Check for proper operation of the air pump and insure the diffuser assembly is creating a rolling motion of the chamber contents.

MANUFACTURED BY

norweco[®]

*Engineering the future of water
and wastewater treatment.*

**NORWECO, INC.
NORWALK, OHIO
U.S.A. 44857**

www.norweco.com

norweco® **HYDRO-KINETIC**®

WASTEWATER TREATMENT SYSTEM TROUBLESHOOTING

During service inspections you may periodically encounter a situation which, if not identified and corrected, will result in interruption of service for the Hydro-Kinetic system. This troubleshooting guide is designed to enable you to isolate the cause of system problems that may be encountered from time to time. Whenever a potential problem is encountered, you should take immediate steps to identify and eliminate the cause. Please note that all areas of installation, including those normally the responsibility of the contractor, excavator, electrician and owner, are covered. You will find that many problems can be traced to causes other than the system or its components. Your help and suggestions in solving these for the owner will save unnecessary expense and will insure maximum system performance.

PLEASE NOTE:

This troubleshooting guide provides efficient and correct solutions to most wastewater treatment problems when used in conjunction with established inspection procedures performed by a factory-trained service technician.

Before responding to a customer service call, check to see that:

- ✓ The service technician that will be assigned to answer the call has been factory-trained and certified by Norweco.
- ✓ Installation and service records for the particular system are up-to-date and have been reviewed.
- ✓ The service technician has a copy of the Hydro-Kinetic Product Manual.
- ✓ The service vehicle has exchange air pumps, recirculation pumps, air pump repair kits, and a fully stocked Tool Kaddy with replacement parts.
- ✓ Clear and concise directions to the installation, including tank and control center location, are given to the service technician.

OPERATIONAL TROUBLESHOOTING

MUD OR SILT IN HYDRO-KINETIC SYSTEM OR HYDRO-KINETIC BIO-FILM REACTOR*

Influent sewer line separated at a joint or fitting	Have contractor excavate and repair
Sewer line crushed	Have contractor excavate and replace
Defective seal around tank inlet or outlet	Excavate and reseal
Hydro-Kinetic tank structurally damaged	Excavate and patch or replace tank
Hydro-Kinetic casting joint improperly sealed	Excavate and seal with non-shrink grout

*Have Hydro-Kinetic system pumped to remove mud after repairs have been completed. Multiple pumpings may be required to remove all mud from the Hydro-Kinetic system. See: Hydro-Kinetic Tank Pumping instructions.

TROUBLESHOOTING (Cont.)

SEPTIC ODOR IN HYDRO-KINETIC SYSTEM

No power to air pump	Place control center power switch in "on" position
Insufficient air delivery to aeration chamber	Service air pump
Incomplete treatment due to hydraulic overloading	See "Hydraulic Overloading of Hydro-Kinetic System"
Water softener backwash discharging into system	Have owner remove backwash line from system
Excessive solids in aeration chamber	Evaluate chamber and pump if necessary
Excessive solids in anoxic chamber	Evaluate chamber and pump if necessary
Circuit breaker tripped	See "Control Center Warning Light Glows/Audible Alarm Sounding"
Improperly sealed pretreatment chamber access cover	Seal pretreatment access cover
Vent cap openings restrict fresh air entry	Clean vent cap openings
Periodic septic odor for no reason	Have sanitary sewer vent checked

HYDRAULIC OVERLOADING OF HYDRO-KINETIC SYSTEM

Ground water entering system through tank joint	Excavate and reseal joint with non-shrink grout or mastic
Ground water entering system through crack in tank	Excavate and repair crack with hydraulic cement
Ground water entering system through defective seal at inlet or outlet line	Excavate and reseal piping as needed
Roofing down spouts, footer drains, sump pump piping or garage and basement floor drains tied into Hydro-Kinetic system influent line	Have contractor relocate improper connection downstream of Hydro-Kinetic system
Check valve is stuck in closed position	Repair or replace check valve

ORGANIC OVERLOADING OF HYDRO-KINETIC SYSTEM

Aeration chamber settled solids test reads in excess of 75%	Evaluate pretreatment chamber - See Hydro-Kinetic Tank Pumping instructions
Aeration chamber solids appear black	Evaluate pretreatment chamber - See Hydro-Kinetic Tank Pumping instructions

FLOATING SOLIDS IN CLARIFICATION CHAMBER OR PLANT EFFLUENT

Excessive sludge on clarifier sidewalls	Scrape hopper side walls
Restriction of flow equalization device	Remove obstruction
Pretreatment chamber discharging excessive solids	Evaluate pretreatment chamber - See Hydro-Kinetic Tank Pumping instructions
Hydraulic overloading of system	See "Hydraulic Overloading of Hydro-Kinetic System"

CONTROL CENTER WARNING LIGHT GLOWS/AUDIBLE ALARM SOUNDING

Liquid in tank at level of high water alarm float	See "Hydraulic Overloading of Hydro-Kinetic System"
Air pump is not running	Check power supply to air pump
Dead short in power line to air pump	Have owner call his electrician

PROGRESS THROUGH

norweco[®]
www.norweco.com

SERVICE SINCE 1906

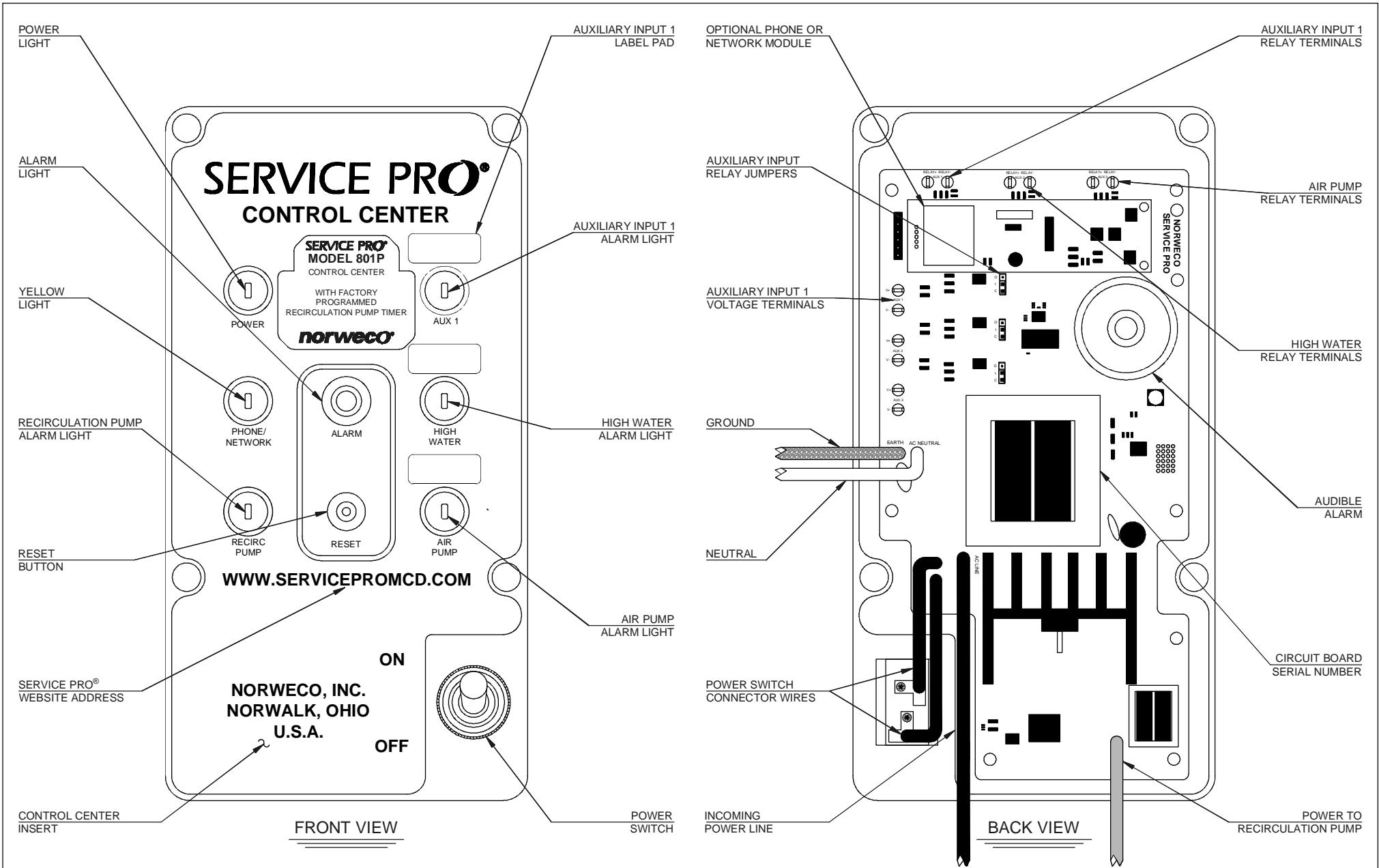

GENERAL NOTES:

1. A DEDICATED 15 AMP CIRCUIT BREAKER AT MAIN SERVICE PANEL SHOULD NOT BE ENERGIZED UNTIL THE RECIRCULATION PUMP IS INSTALLED AND READY TO BE PLACED INTO OPERATION.
2. INSURE THE RECIRCULATION PUMP IS OPERATING WHEN THE FACILITY IS OCCUPIED.
3. THE LOCAL, LICENSED NORWECO DISTRIBUTOR WILL PLACE THE RECIRCULATION PUMP INTO SERVICE.
4. BLACK INSULATOR NOT SHOWN FOR CLARITY.

U.S. AND FOREIGN PATENTS PENDING	norweco		REVISIONS	REVISED
	SERVICE PRO® MODEL 801P CONTROL CENTER PICTORIAL		9-9-13	A
© MMXIII			APPROVED BY	SSS
			DATE	JMM
			SCALE	8-26-13
		DRAWING NO.	NTS	
		THIS DRAWING IS THE PROPERTY OF NORWECO. IT IS TO BE USED FOR THE SPECIFIC PROJECT AND ANY REUSE OR REPRODUCTION IN WHOLE OR IN PART WITHOUT WRITTEN PERMISSION FROM NORWECO IS PROHIBITED.		PC-5-7716

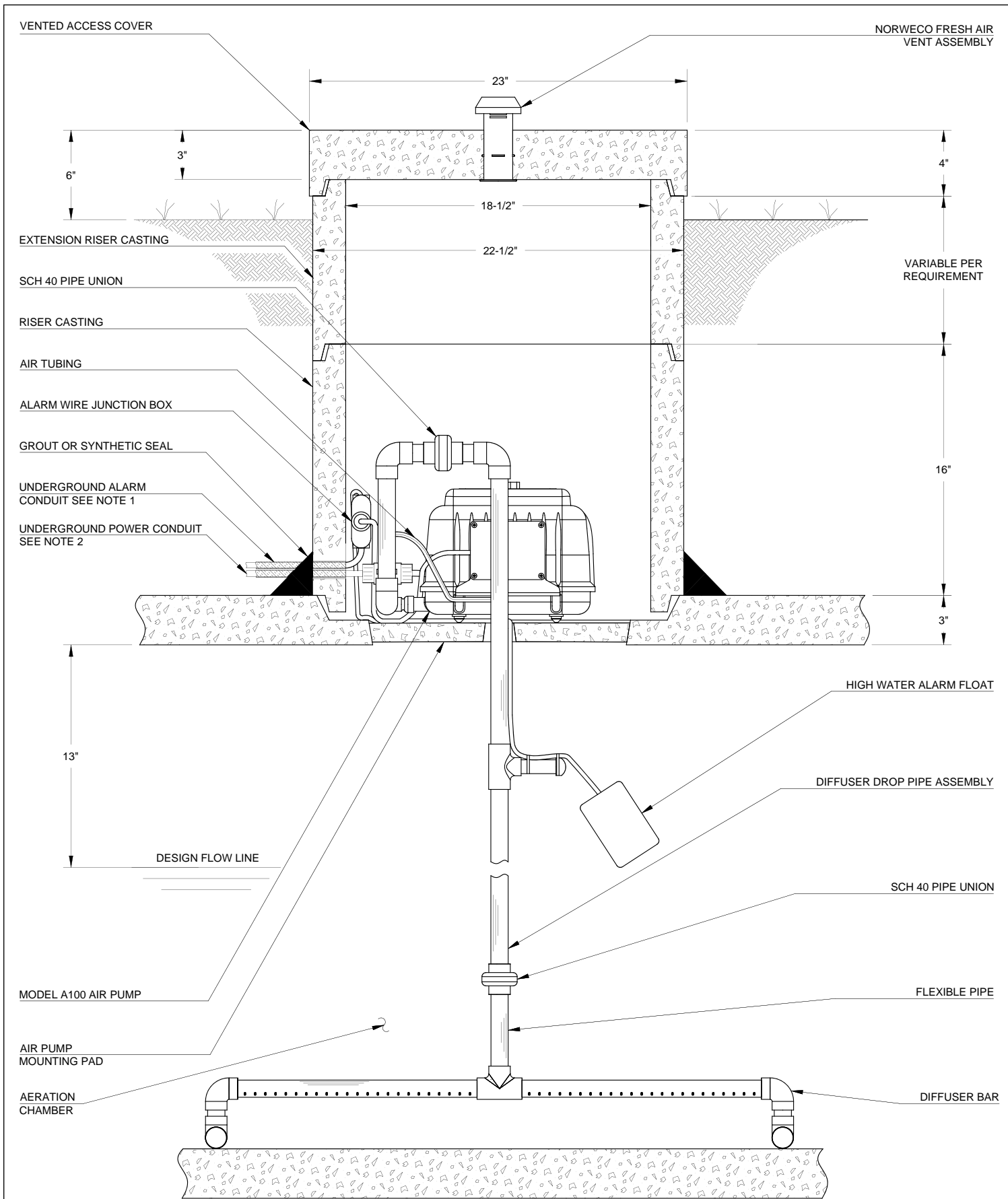

GENERAL NOTES:

1. ROUTE ALARM WIRES FROM JUNCTION BOX IN A SEPARATE CONDUIT DIRECTLY TO AN APPROVED SERVICE PRO® CONTROL CENTER.
2. UNDERGROUND POWER SUPPLY MUST BE WIRED INTO AN APPROVED SERVICE PRO® CONTROL CENTER.
3. SERVICE PRO® CONTROL CENTER MUST BE WIRED INTO A SEPARATE 15 AMP CIRCUIT BREAKER AT MAIN ELECTRICAL SERVICE PANEL IN THE FACILITY.
4. AIR PUMP AND CONTROL CENTER MUST BE PROPERLY GROUNDED.
5. THE LOCAL, LICENSED NORWECO DISTRIBUTOR WILL PLACE THE AIR PUMP INTO SERVICE.

U.S. AND FOREIGN PATENTS PENDING © MMXIII	<i>norweco</i>	REVISION DATE	REVISION
	HYDRO-KINETIC® MODEL A100 AIR PUMP AND PLUMBING INSTALLATION DETAIL	9-9-13	A
		APPROVED BY	SSS
		DATE	JMM 8-26-13
	SCALE	NTS	DRAWING NO.
		PC-5-1022	

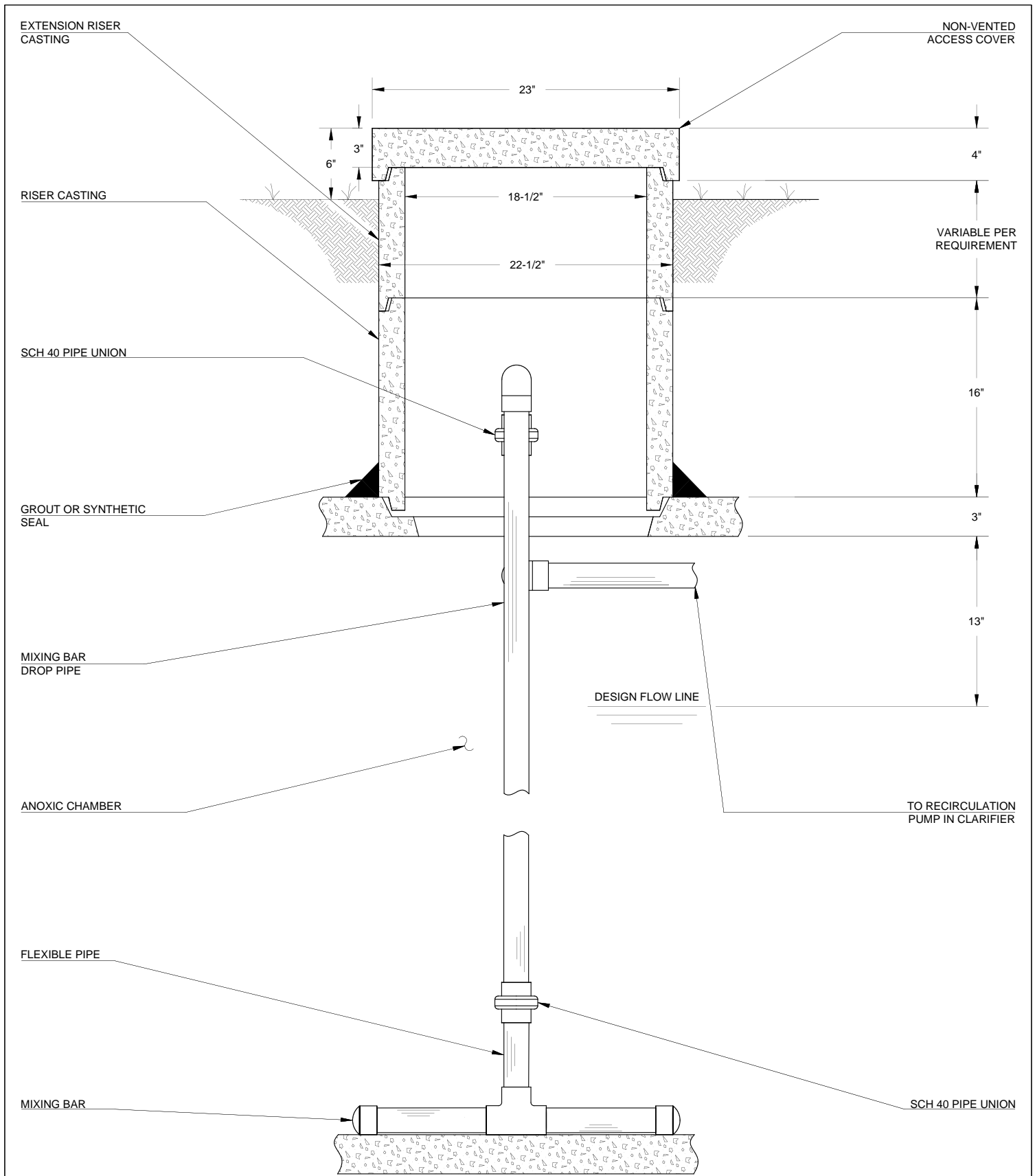

GENERAL NOTES:

1. UNDERGROUND POWER SUPPLY MUST BE WIRED INTO AN APPROVED SERVICE PRO® CONTROL CENTER.
2. SERVICE PRO® CONTROL CENTER MUST BE WIRED INTO A SEPARATE 15 AMP CIRCUIT BREAKER AT MAIN ELECTRICAL SERVICE PANEL IN THE FACILITY.
3. RECIRCULATION PUMP AND CONTROL CENTER MUST BE GROUNDED.
4. THE LOCAL, LICENSED NORWECO DISTRIBUTOR WILL PLACE THE RECIRCULATION PUMP INTO SERVICE.

U.S. AND FOREIGN PATENTS PENDING © MMXIII	norweco	REVISION DATE: 9-9-13	REVISION: A
	HYDRO-KINETIC® MIXING BAR ASSEMBLY DETAIL	DESIGNER: SSS	APPROVED BY: JMM
		DATE: 8-26-13	SCALE: NTS
		<small>THIS DRAWING IS THE PROPERTY OF NORWECO. ANY REPRODUCTION OR TRANSMISSION OF THIS DRAWING IN ANY FORM WITHOUT WRITTEN PERMISSION FROM NORWECO.</small>	
		DRAWING NO. PC-5-1023	

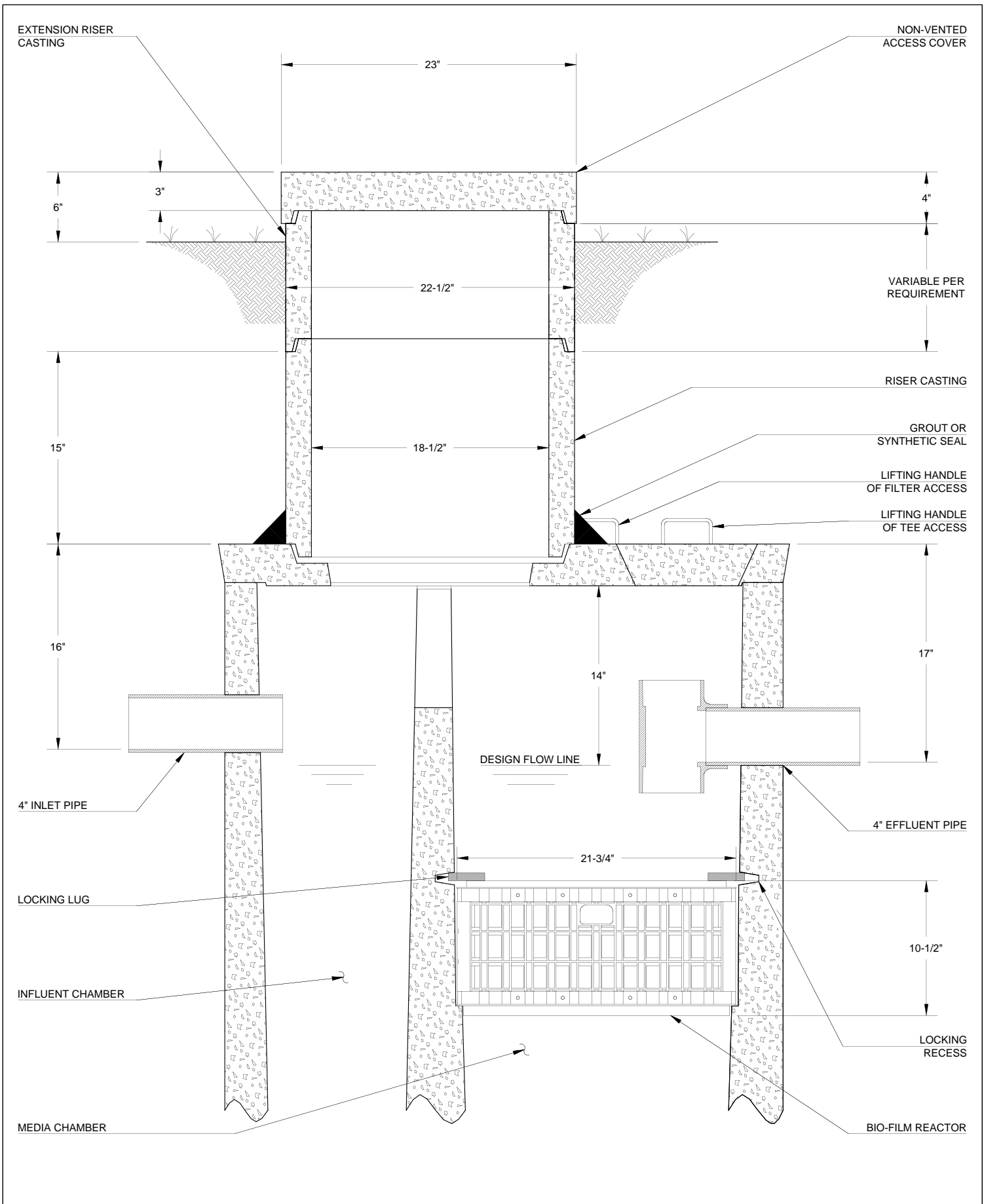

GENERAL NOTES:

1. BIO-FILM REACTORS SHOULD BE INSERTED THROUGH THE RECTANGULAR OPENINGS ON THE TOP OF THE TANK.
2. CENTER BIO-FILM REACTORS SO THEY ARE TOUCHING AND EXTEND LOCKING LUGS INTO THE RECESSES IN THE TANK.
3. THE INLET PIPE SHOULD ONLY EXTEND THREE INCHES INTO THE HYDRO-KINETIC® FILTER.

U.S. AND FOREIGN PATENTS PENDING © MMXIII	norweco		REVISION DATE	REVISION
			9-9-13	A
			DRAWN BY	SSS
			APPROVED BY	JMM
		DATE	8-26-13	
		SCALE	NTS	
		DRAWING NO.	PC-5-1024	

THIS DRAWING IS THE PROPERTY OF NORWECO. IT IS TO BE USED ONLY FOR THE PROJECT AND SITE SPECIFICALLY IDENTIFIED HEREON. IT IS NOT TO BE REPRODUCED OR TRANSMITTED IN ANY FORM OR BY ANY MEANS WITHOUT WRITTEN PERMISSION FROM NORWECO.

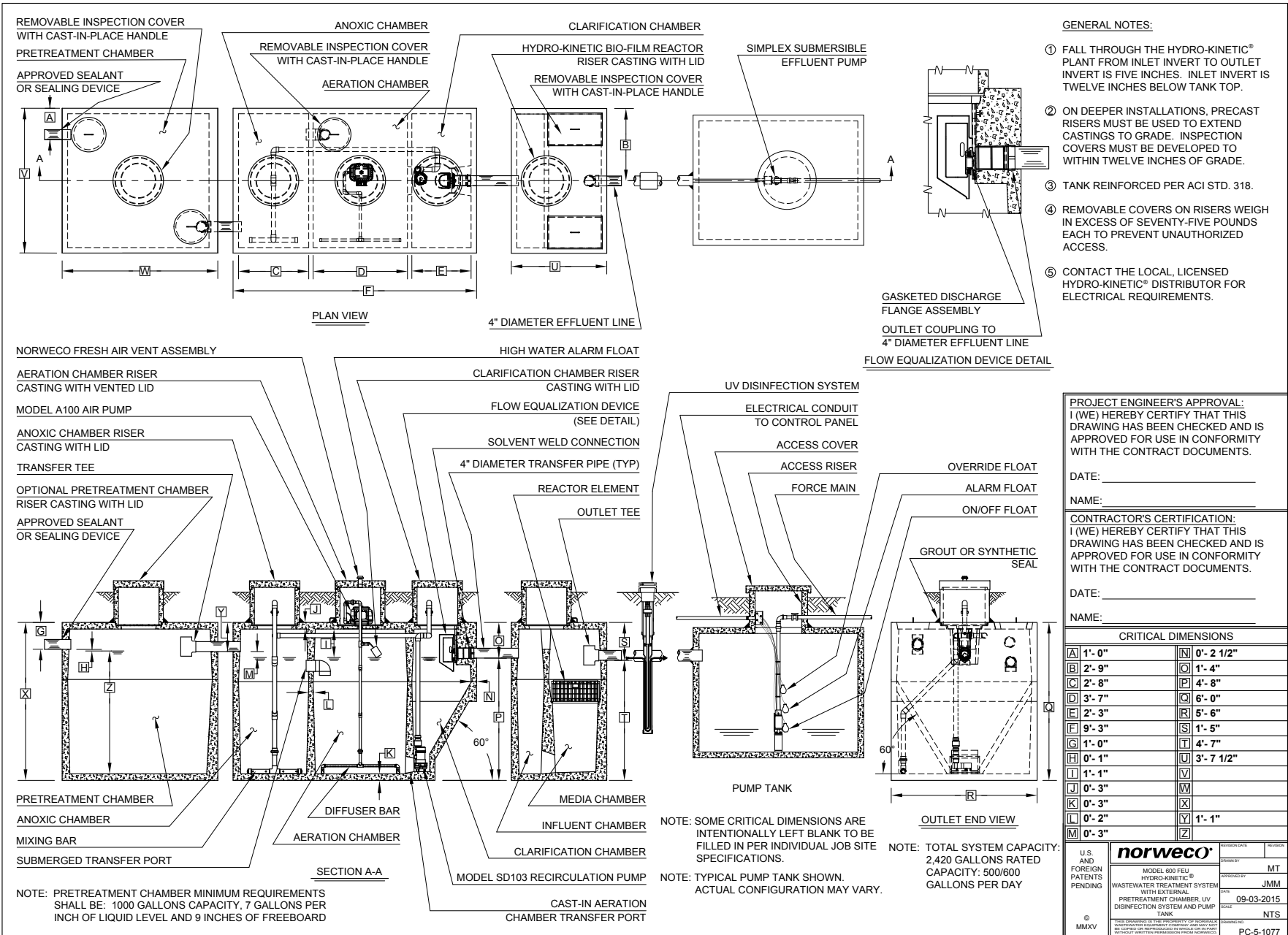

- GENERAL NOTES:**
- FALL THROUGH THE HYDRO-KINETIC® PLANT FROM INLET INVERT TO OUTLET INVERT IS FIVE INCHES. INLET INVERT IS TWELVE INCHES BELOW TANK TOP.
 - ON DEEPER INSTALLATIONS, PRECAST RISERS MUST BE USED TO EXTEND CASTINGS TO GRADE. INSPECTION COVERS MUST BE DEVELOPED TO WITHIN TWELVE INCHES OF GRADE.
 - TANK REINFORCED PER ACI STD. 318.
 - REMOVABLE COVERS ON RISERS WEIGH IN EXCESS OF SEVENTY-FIVE POUNDS EACH TO PREVENT UNAUTHORIZED ACCESS.
 - CONTACT THE LOCAL, LICENSED HYDRO-KINETIC® DISTRIBUTOR FOR ELECTRICAL REQUIREMENTS.

PROJECT ENGINEER'S APPROVAL:
 I (WE) HEREBY CERTIFY THAT THIS DRAWING HAS BEEN CHECKED AND IS APPROVED FOR USE IN CONFORMITY WITH THE CONTRACT DOCUMENTS.

DATE: _____
 NAME: _____

CONTRACTOR'S CERTIFICATION:
 I (WE) HEREBY CERTIFY THAT THIS DRAWING HAS BEEN CHECKED AND IS APPROVED FOR USE IN CONFORMITY WITH THE CONTRACT DOCUMENTS.

DATE: _____
 NAME: _____

CRITICAL DIMENSIONS

A	1'-0"	N	0'-2 1/2"
B	2'-9"	O	1'-4"
C	2'-8"	P	4'-8"
D	3'-7"	Q	6'-0"
E	2'-3"	R	5'-6"
F	9'-3"	S	1'-5"
G	1'-0"	T	4'-7"
H	0'-1"	U	3'-7 1/2"
I	1'-1"	V	
J	0'-3"	W	
K	0'-3"	X	
L	0'-2"	Y	1'-1"
M	0'-3"	Z	

NOTE: SOME CRITICAL DIMENSIONS ARE INTENTIONALLY LEFT BLANK TO BE FILLED IN PER INDIVIDUAL JOB SITE SPECIFICATIONS.

NOTE: TYPICAL PUMP TANK SHOWN. ACTUAL CONFIGURATION MAY VARY.

NOTE: TOTAL SYSTEM CAPACITY: 2,420 GALLONS RATED CAPACITY: 500/600 GALLONS PER DAY

NOTE: PRETREATMENT CHAMBER MINIMUM REQUIREMENTS SHALL BE: 1000 GALLONS CAPACITY, 7 GALLONS PER INCH OF LIQUID LEVEL AND 9 INCHES OF FREEBOARD

U.S. AND FOREIGN PATENTS PENDING © MMXV	MODEL 600 FEU HYDRO-KINETIC® WASTEWATER TREATMENT SYSTEM WITH EXTERNAL PRETREATMENT CHAMBER, UV DISINFECTION SYSTEM AND PUMP TANK	DESIGN DATE: _____ DESIGNED BY: MT APPROVED BY: JMM DATE: 09-03-2015 SCALE: NTS	DRAWING NO.: PC-5-1077
--	---	---	------------------------

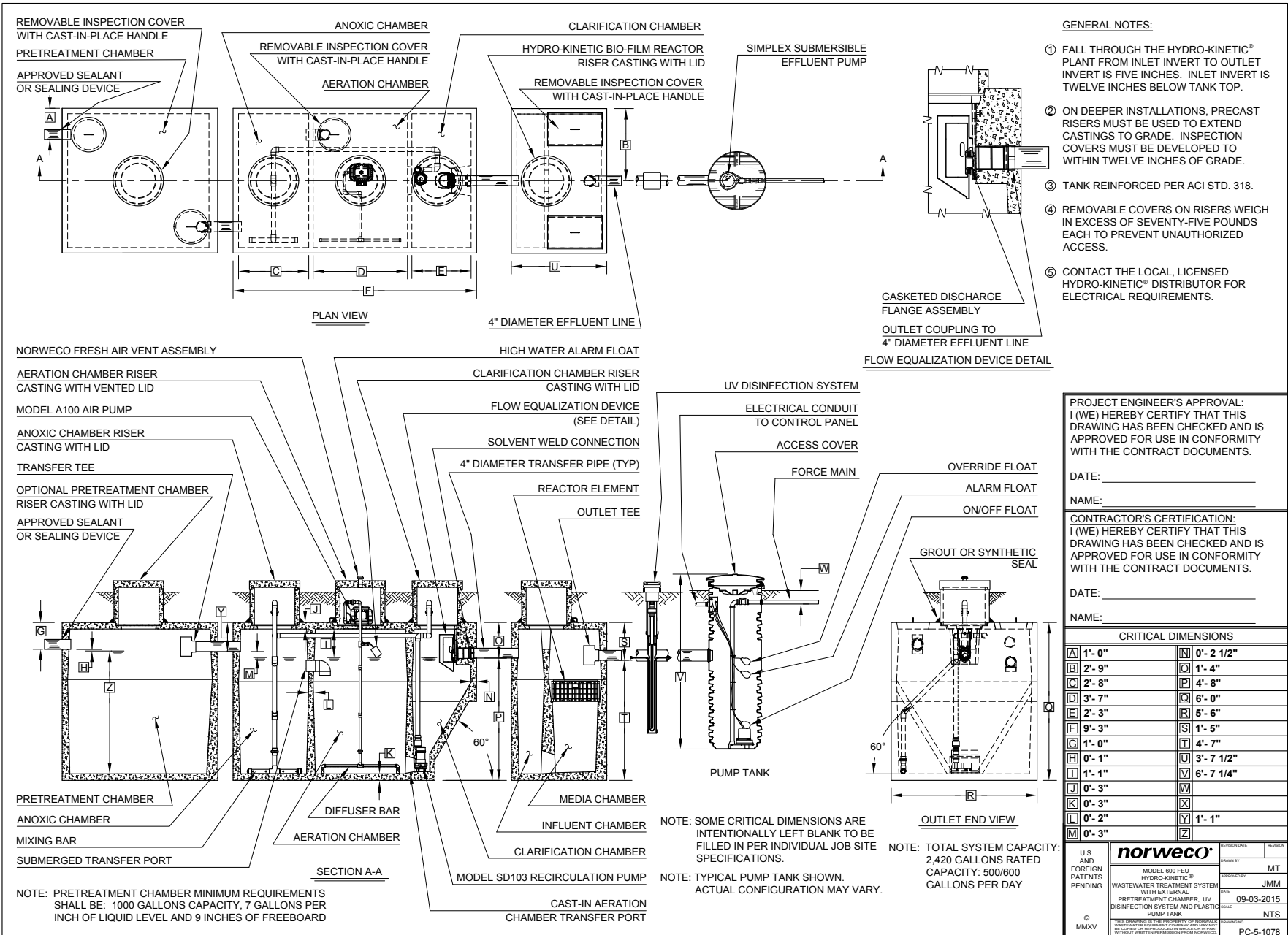

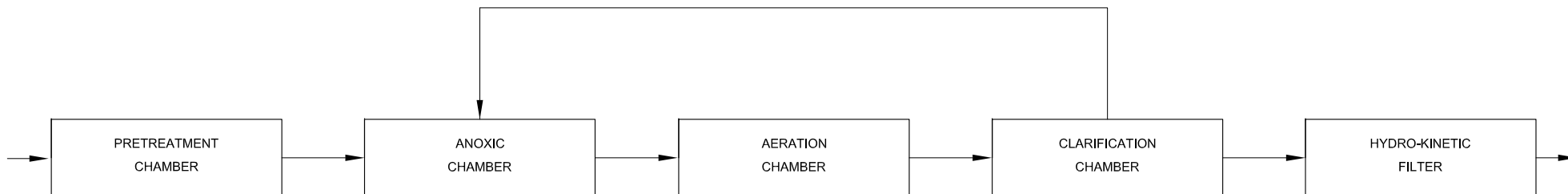

U.S. AND FOREIGN PATENTS PENDING		norweco		REVISION DATE	REVISION
				DESIGNED BY	SSS
© MMXIII		HYDRO-KINETIC SYSTEM FLOW CHART		APPROVED BY	JMM
				DATE	11-05-2013
				SCALE	NA
THIS DOCUMENT IS THE PROPERTY OF NORWECO. IT IS TO BE KEPT IN CONFIDENTIALITY AND NOT BE COPIED OR REPRODUCED IN WHOLE OR IN PART WITHOUT THE PERMISSION FROM NORWECO.		DRAWN BY	PC-7-4055		