

## EXHIBIT I – Application for Site Certificate

### SOILS

OAR 345-021-0010(1)(i)

#### REVIEWER CHECKLIST

(i) Exhibit I. Information from reasonably available sources regarding soil conditions and uses in the analysis area, providing evidence to support findings by the Council as required by OAR 345-022-0022, including:

Rule Sections	Section	✓
(A) Identification and description of the major soil types in the analysis area.	1.2	
(B) Identification and description of current land uses in the analysis area, such as growing crops, that require or depend on productive soils.	1.3	
(C) Identification and assessment of significant potential adverse impact to soils from construction, operation and retirement of the facility, including, but not limited to, erosion and chemical factors such as salt deposition from cooling towers, land application of liquid effluent, and chemical spills.	1.4	
(D) A description of any measures the applicant proposes to avoid or mitigate adverse impact to soils.	1.5	
(E) The applicant's proposed monitoring program, if any, for adverse impact to soils during construction and operation.	1.6	



**EXHIBIT I – Application for Site Certificate**

**SOILS**

OAR 345-021-0010(1)(i)

**TABLE OF CONTENTS**

**I.1 INTRODUCTION.....I-1**

**I.2 SOIL TYPES .....I-1**

    I.2.1 Definitions of Relevant Soils Properties.....I-2

    I.2.2 Properties of Soil Types in the Analysis Area .....I-5

**I.3 LAND USES .....I-8**

**I.4 POTENTIAL ADVERSE IMPACTS .....I-8**

    I.4.1 Compaction.....I-9

    I.4.2 Wind Erosion .....I-9

    I.4.3 Water Erosion .....I-10

    I.4.4 Conversion of Existing Vegetation.....I-11

    I.4.5 Application of Liquid Effluent.....I-11

    I.4.6 Chemical Spills .....I-12

    I.4.7 Noxious Weeds .....I-12

    I.4.8 Other Potential Soil Impacts .....I-13

**I.5 PROPOSED MEASURES.....I-13**

**I.6 MONITORING PROGRAM.....I-16**

**I.7 REFERENCES.....I-16**

**TABLES**

Table I-1 Soil Types within the Analysis Area .....I-2  
Table I-2 Physical Properties and Land Capability Class of the Soil Types within the  
Analysis Area.....I-4

**FIGURES**

Figure I-1 Soil Map Units (Soil Types)

**APPENDICES**

Appendix I-1 NPDES 1200-C Construction Stormwater Permit Application and DEQ  
Confirmation of Receipt

Appendix I-2 Draft Spill Management Plan

## **I.1 INTRODUCTION**

Obsidian Solar Center LLC (Applicant) proposes to construct the Obsidian Solar Center (Facility) in Lake County, Oregon, with an alternating current generating capacity of up to 400 megawatts. Please refer to Exhibit B for Facility layout information and Exhibit C for Facility location information.

Exhibit I addresses the potential impacts of the proposed Facility on soils within the analysis area, which the Project Order defines as the area within the site boundary and 500 feet from the site boundary. Figure I-1 depicts soil types within the analysis area. This exhibit provides the information required by Oregon Administrative Records (OAR) 345-021-0010(1)(i): *Information from reasonably available sources regarding soil conditions and uses in the analysis area, providing evidence to support findings by the Council as required by OAR 345-022-0022.*

As described in Exhibit B, this Application for Site Certificate analyzes the potential impacts from two design scenarios: a stand-alone photovoltaic (PV) solar power generation build-out, and a PV solar power generation plus battery storage build-out. This exhibit analyzes the PV plus battery storage design scenario, which will likely have a greater potential impact on soils than stand-alone PV due to the larger footprint and inclusion of battery storage enclosures.

### **Executive Summary**

The evidence presented in this exhibit demonstrates that Facility construction, operation, and retirement will not cause significant adverse impacts on soils. Construction of roads, PV arrays, and other Facility components will be regulated by a National Pollution Discharge Elimination System (NPDES) 1200-C Construction Stormwater Permit, which will include an erosion and sediment control plan with the required erosion and sediment control best management practices (BMPs). In addition, Applicant will implement other measures designed to avoid or minimize impacts on soils, including, but not limited to, implementation of a Spill Management Plan (refer to Appendix I-2).

Applicant does not propose any specific or unique condition of approval pertaining to soils for the Site Certificate.

## **I.2 SOIL TYPES**

**OAR 345-021-0010(1)(i)(A)** *Identification and description of the major soil types in the analysis area.*

Response: There are five soil map units (hereafter referred to as soil types) within the analysis area, as identified by the Soil Survey Geographic Database, which is managed by the Natural Resources Conservation Service (NRCS; Soil Survey Staff, NRCS 2017). Figure I-1 depicts the locations and geographic extents of the soil types within the analysis area, and Table I-1 presents the acreage of each soil type within the analysis area.

**Table I-1 Soil Types within the Analysis Area**

<b>Soil Map Unit #</b>	<b>Soil Type (Map Unit) Name</b>	<b>Area A (acres)</b>	<b>Area D (acres)</b>	<b>Gen-tie Corridor (acres)</b>	<b>500-foot Buffer Area (acres)</b>	<b>Total</b>
200	Abert ashy loamy sand, 0 to 2 percent slopes	1,546.4	0	0	398.3	1,944.7
217	Bonnick-Fort Rock complex, 0 to 2 percent slopes	289.6	0	0	53.2	342.8
470	Morehouse ashy loamy fine sand, 0 to 2 percent slopes	1,081.9	43.8	11.8	617.2	1,754.7
472	Morehouse ashy loamy fine sand, 2 to 20 percent slopes	931.8	0	2.9	137.1	1,071.8
667	Wegert-Kunceider complex, cool, 0 to 15 percent slopes	13.1	0	0	32.9	46.0
<i>Total</i>		<b>3,862.8</b>	<b>43.8</b>	<b>14.7</b>	<b>1,238.7</b>	<b>5,160.1</b>

### **I.2.1 Definitions of Relevant Soils Properties**

This section provides descriptions of soil properties for the soil types located in the analysis area. These properties include hydrologic soil group (HSG), wind erodibility group (WEG), soil erodibility factor (Kw), subsidence, and frost action. Land Capability Class (LCC) and subclass are also discussed.

#### **Hydrologic Soil Groups**

HSG is determined by the water transmitting soil layer with the lowest saturated hydraulic conductivity and depth to any layer that is more or less water impermeable or depth to a water table, if present (NRCS 2007). The least transmissive layer can be any soil layer (horizon) that transmits water at a slower rate relative to those horizons above or below it (NRCS 2007). Refer to Table I-2 for the HSGs for each soil type in the analysis area.

The four HSGs are:

- **Group A:** Soils with low runoff potential when saturated due to free transmission of water through the soil.

- **Group B:** Soils with moderately low runoff potential when saturated due to mostly unimpeded transmission of water through the soil.
- **Group C:** Soils with moderately high runoff potential when saturated due to somewhat restricted transmission of water through the soil.
- **Group D:** Soils with high runoff potential when saturated due to restricted transmission of water through the soil. (NRCS 2007)

## **Wind Erodibility Groups**

WEGs are soils that have a similar susceptibility to wind erosion in cultivated areas. The soils are assigned to Groups 1–8, with Group 1 being the most susceptible to wind erosion, and those assigned to Group 8 being the least susceptible (NRCS 2007). There is a close correlation between wind erosion potential and the texture of the surface layer, the size and durability of surface clods, rock fragments, organic matter, and a calcareous reaction (NRCS 2007). Soil moisture and frozen soil layers also influence wind erosion (NRCS 2012). Refer to Table I-2 for the WEGs for each soil type in the analysis area.

## **Soil Erodibility Factors**

K<sub>w</sub> is a quantitative estimate of a soil's intrinsic susceptibility to erosion by runoff and raindrop impact. K<sub>w</sub> applies to the whole soil, but values are provided for distinct soil horizons (NRCS 2007). Values range from 0.02, most resistant to water erosion, to 0.69, most susceptible to water erosion and/or most potential to generate runoff (NRCS 2007). Values from 0.25 to 0.4 indicate a moderate level of water erosion potential. K<sub>w</sub> values are dependent upon soil texture, structure, permeability, and organic matter content (NRCS 2007). In general, soils that are relatively permeable (typically coarse-textured), possess moderate to high levels of organic matter, and sustain good soil structure have a greater resistance to erosion and, therefore, lower K<sub>w</sub> values (NRCS 2012). Refer to Table I-2 for the soil erodibility values for each soil type in the analysis area.

## **Subsidence**

Subsidence is the settlement of organic soils or of saturated mineral soils with very low density. Subsidence generally results from either desiccation and shrinkage or oxidation of organic material, or both, following drainage. Subsidence takes place gradually, usually over a period of several years. Table I-2 shows the expected initial subsidence, which usually is a result of drainage, and total subsidence, which results from a combination of factors for soil types in the analysis area. (NRCS 2012)

**Table I-2 Physical Properties and Land Capability Class of the Soil Types within the Analysis Area**

Soil Map Unit #	Soil Type (Map Unit) Name	Hydrologic Soil Group	Wind Erodibility Group	Soil Erodibility Factor <sup>a</sup>	Subsidence – Initial/Total	Frost Action Potential	Land Capability Class and Subclass
200	Abert ashy loamy sand, 0 to 2 percent slopes	B	1	0.2	0 /---	Low	VI <sub>s</sub>
217	Bonnick-Fort Rock complex, 0 to 2 percent slopes	A	1	Bonnick = 0.1; Fort Rock = 0.05	0 /---	Low	VI <sub>s</sub>
470	Morehouse ashy loamy fine sand, 0 to 2 percent slopes	A	1	0.28	0 /---	Low	VI <sub>s</sub>
472	Morehouse ashy loamy fine sand, 2 to 20 percent slopes	A	1	0.28	0 /---	Low	VI <sub>e</sub>
667	Wegert-Kunceider complex, cool, 0 to 15 percent slopes	D	1	Wegert = 0.05; Kunceider = 0.1	0 /---	Low	VI <sub>e</sub>

Sources: NRCS 2007, 2012

Note:

<sup>a</sup> Soil erodibility factor values apply to uppermost horizon of each soil type and/or component

### **Frost Action**

Frost action is the upward or lateral expansion of soil caused by the formation of segregated ice lenses (frost heave) and the subsequent collapse of the soil and loss of strength upon thawing (NRCS 2007). The NRCS evaluation of expected frost action assumes that the soil is not insulated by vegetation or snow and is not artificially drained (NRCS 2007). Silty and highly structured, clayey soils that have a high water table in winter are the most susceptible to frost action (NRCS 2007). Well drained, very gravelly, or very sandy soils are the least susceptible. Frost heave and low soil strength during thawing cause damage to pavements and other rigid structures (NRCS 2012). Refer to Table I-2 for the frost action potential for each soil type in the analysis area.

### **Land Capability Class**

LCC is a system of grouping soil type components primarily on their capability to produce common cultivated crops and pasture plants without causing soil deterioration over a long (though undefined) period of time, managed by the NRCS (n.d.). There are eight classes, ranging from Class I, which denotes soils with slight limitations that restrict their use, to Class VIII, which denotes soils and miscellaneous areas that have limitations precluding their use for



commercial plant production and thereby restricts them to recreation, wildlife, water supply, or aesthetic purposes. Soils belonging to Classes V through VIII are generally shallow, possess drainage problems, and/or commonly occur in steep and rocky areas. Lands like these are typically limited in use to pasture, range, wood production, wildlife habitat, watershed protection, and/or recreation. Class V through VIII soils with no history of irrigation are considered non-arable and are not suitable for cultivation in all cases (OAR 660-033-130 (38)). (NRCS 2012)

LCCs are also often expressed with one of four subclasses (e, w, s, or c) that denotes susceptibility to erosion. The two subclasses presented in Table I-2 are “e,” which indicates susceptibility to erosion as the dominant problem affecting their use, and “s,” which indicates limitations within the rooting zone, such as shallow rooting depth, abundance of stones, low moisture-holding capacity, low fertility that is difficult to correct, and salinity or sodium content. All LCCs and subclasses presented in this exhibit are for non-irrigated soil; no values are available for irrigated soil in the analysis area (NRCS 2012).

## **I.2.2 Properties of Soil Types in the Analysis Area**

The following sections provide descriptions of each soil type based on information derived from the Soil Survey of Lake County, Oregon, Northern Part (NRCS 2012). The descriptions include factors that influence soil development, a brief description of the upper part of the soil profile, and a discussion of each soil type’s hydrologic regime, relevant physical properties, and LCC and subclass.

Of the five soil types within the analysis area, three are consociations, which are soil types dominated by a single component and similar soils, and two are complexes, which are soil types that consist of two or more dominant soil components that are intricately interspersed. For the consociations, the NRCS has assigned a single value for WEG and Kw. For the complexes, values for wind erodibility and Kw are presented for each co-dominant component unless the values for each component are identical.

### **I.2.2.1 Abert Ashy Loamy Sand, 0 to 2 Percent Slopes (Map Unit 200)**

The Abert ashy loamy sand consists of very deep, moderate to moderately slow permeable, well drained soils that formed in eolian material derived from volcanic ash over lacustrine deposits derived from mixed volcanic rocks and volcanic ash. Abert ashy loamy sand soils are found on lakebeds. In a representative profile, the surface layer is grayish brown ashy loamy sand about 2 inches thick. The subsoil is light brownish gray ashy sandy loam about 6 inches thick. These layers are pH neutral or circum-neutral (pH 7.0–7.2). The substratum is pale brown ashy loam about 5 inches thick and is moderately alkaline. (NRCS 2012)

The HSG for this soil type is Group B due to the moderately deep profile, moderate proportion of coarse-textured particles, and lack of impermeable layers. The seasonal high water table is more than 72 inches below ground surface. This soil's susceptibility to wind erosion is very high, whereas its susceptibility to erosion by runoff and raindrop impact is moderately low. There is no potential for subsidence and the potential for frost action is low. The LCC and subclass for this soil type is VIs for non-irrigated land. This soil type is used for irrigated croplands, livestock grazing, and wildlife habitat in the analysis area. (NRCS 2012)

#### **I.2.2.2 Bonnick-Fort Rock Complex, 0 to 2 Percent Slopes (Map Unit 217)**

The Bonnick-Fort Rock complex consists of very deep, rapid permeable, somewhat excessively drained soils that formed in volcanic ash and lacustrine deposits derived from volcanic rocks, such as basalt and tuff. Both Bonnick and Fort Rock soils are found on lake terraces. In a representative profile, the surface layer is grayish brown ashy loamy sand about 3 inches thick. The subsoil is grayish brown gravelly ashy loamy sand about 7 inches thick. The substratum is pale brown gravelly ashy loamy sand about 18 inches thick. Each of these layers is typically mildly alkaline (pH 7.4–7.8). (NRCS 2012)

The HSG for this soil type is Group A due to the deep profile, high proportion of coarse-textured particles, and lack of impermeable layers. The seasonal high water table is more than 72 inches below ground surface. This soil type's susceptibility to wind erosion is very high, whereas its susceptibility to erosion by runoff and raindrop impact is low. There is no potential for subsidence and the potential for frost action is low. The LCC and subclass for this soil type is VIs for non-irrigated land. This soil type is used for irrigated cropland, livestock grazing, and wildlife habitat in the analysis area. (NRCS 2012)

#### **I.2.2.3 Morehouse Ashy Loamy Fine Sand, 0 to 2 Percent Slopes (Map Unit 470)**

Morehouse ashy loamy fine sand soils consist of very deep, somewhat excessively drained soils that formed in eolian sand and volcanic ash over lacustrine deposits derived from volcanic rocks. The Morehouse series soils are found on stable dunes in basins on lakebeds. In a representative profile, the surface layer is grayish brown ashy loamy fine sand about 5 inches thick. The subsoil is grayish brown ashy loamy sand about 17 inches thick. The substratum is light brownish gray ashy loamy sand about 19 inches thick. Each of these layers is typically strongly alkaline (pH 8.5–9.0). (NRCS 2012)

The HSG for this soil type is Group A due to the deep profile, high proportion of coarse-textured particles, and lack of impermeable layers. The seasonal high water table is more than 72 inches below ground surface. This soil type's susceptibility to wind erosion is very high, whereas its susceptibility to erosion by runoff and raindrop impact is moderate. There is no potential for subsidence and the potential for frost action is low. The LCC and subclass for this soil type is

VIs for non-irrigated land. This soil type is used for irrigated cropland, livestock grazing, and wildlife habitat in the analysis area. (NRCS 2012)

#### **I.2.2.4 Morehouse Ashy Loamy Fine Sand, 2 to 20 Percent Slopes (Map Unit 472)**

Morehouse ashy loamy fine sand soils consist of very deep, somewhat excessively drained soils that formed in eolian sand and volcanic ash over lacustrine deposits derived from volcanic rocks. Morehouse series soils are found on stable dunes in basins on lakebeds. In a representative profile, the surface layer is grayish brown ashy loamy fine sand about 5 inches thick. The subsoil is grayish brown ashy loamy sand about 17 inches thick. The substratum is light brownish gray ashy loamy sand about 19 inches thick. Each of these layers is typically strongly alkaline (pH 8.5–9.0). Each of these layers in the local phase of this map unit is typically strongly alkaline (pH 8.5–9.0). (NRCS 2012)

The HSG for this soil type is Group A due to the deep profile, high proportion of coarse-textured particles, and lack of impermeable layers. The seasonal high water table is more than 72 inches below ground surface. This soil type's susceptibility to wind erosion is very high, whereas its susceptibility to erosion by runoff and raindrop impact is moderate. There is no potential for subsidence and the potential for frost action is low. The LCC and subclass for this soil type is VIe for non-irrigated land. This soil type is used for irrigated cropland, livestock grazing, and wildlife habitat in the analysis area. (NRCS 2012)

#### **I.2.2.5 Wegert-Kunceider Complex, Cool, 0 to 15 Percent Slopes (Map Unit 667)**

Wegert-Kunceider complex soils consists of shallow to moderately deep, moderately rapid permeable, somewhat excessively drained soils that formed in volcanic ash and pumice over residuum derived from basalt. Both Wegert and Kunceider series soils are found on lava plains and lava plateaus underlain by fractured basalt. In a representative profile, the surface layer is dark grayish brown gravelly ashy loamy sand about 2 inches thick. The subsoil is grayish brown ashy loamy sand about 4 inches thick. These layers are typically neutral to circum-neutral (pH 7.0–7.2). The substratum is pale brown extremely cobbly ashy loamy sand about 9 inches thick. This layer is typically slightly alkaline (pH 7.4–7.8). (NRCS 2012)

Although the HSG for the Wegert component is Group A, the HSG for this soil type is Group D due to the Kunceider component's shallow profile and underlayment by relatively impermeable bedrock. As a result, the soil type belongs to the Group D HSG. This soil type does not support ponding or flooding. The seasonal high water table is more than 72 inches below ground surface. This soil type's susceptibility to wind erosion is very high, whereas its susceptibility to erosion by runoff and raindrop impact is low. The LCC and subclass for this soil type is VIe for non-irrigated land. This soil type is used for irrigated cropland, livestock grazing, and wildlife habitat in the analysis area. (NRCS 2012)

### **I.3 LAND USES**

**OAR 345-021-0010(1)(i)(B)** *Identification and description of current land uses in the analysis area, such as growing crops, that require or depend on productive soils.*

Response: The predominant land use in the analysis area is cattle grazing at intensities ranging from very light to moderate. The land within the Facility site boundary is not irrigated. However, there are portions of land in the analysis area, but they are outside of the site boundary that are irrigated and used for crop cultivation. With the exception of one section owned by the Oregon Department of State Lands and a county road in the generation tie (gen-tie) transmission line corridor, the land within the analysis area is privately owned and primarily undeveloped, except for some dirt roads, barbed wire fences, and rudimentary cattle corals. In addition, there are three existing 500 kilovolt transmission lines with steel lattice towers, and several smaller distribution lines with wood poles in the analysis area.

### **I.4 POTENTIAL ADVERSE IMPACTS**

**OAR 345-021-0010(1)(i)(C)** *Identification and assessment of significant potential adverse impact to soils from construction, operation and retirement of the facility, including, but not limited to, erosion and chemical factors such as salt deposition from cooling towers, land application of liquid effluent, and chemical spills.*

Response: This exhibit describes temporary impacts as short term (less than one year) and long term (more than one year). Permanent impacts refer to impacts lasting for the life of the Facility, i.e., 30 years. Temporarily disturbed areas will be restored after construction and permanently disturbed areas will be restored after retirement. The following section describes potential adverse impacts to soil from compaction, water and wind erosion, conversion of existing vegetation, application of liquid effluent, chemical spills, and noxious weeds, all as they relate to Facility construction, operation, and retirement activities.

During construction, vegetation in the majority of the areas within the site boundary will be mowed, but no direct soil disturbance will occur. Permanent disturbances to soils from excavation or grading will occur in a relatively small area within the site boundary. These soil disturbances will largely be limited to the areas needed for access roads; gravel/concrete pads for structures, such as the operation and maintenance buildings; and inter-connection equipment, such as inverters. The disturbance caused by construction of the roads and structural foundations will contribute most of the permanent impacts to soils. Trenches to install underground cables for the electrical collection system will result in temporary impacts on soils.

Installation of the solar modules will require relatively little grading, excavation, or other direct soil impacts. Instead, Applicant will mow vegetation in solar module installation areas to within 6 inches of the ground surface, or construction vehicles will drive on and crush vegetation,

before beginning other construction activities in all areas within the site boundary, with the exception of most of the gen-tie transmission line corridor.

Solar modules will be mounted on racks arranged in rows and supported by posts hydraulically driven into the ground. Rubber-tired vehicles will be used to access the locations where solar modules will be installed. These actions will have a temporary impact on soils.

During installation of poles in the gen-tie transmission line corridor, construction crews will park work trucks on the road and in the disturbed road shoulder. There will be permanent soil impacts on 6-foot diameter areas at each pole installation site. As such, there will be approximately 0.02 acres of permanent soil impacts associated with the installation of the gen-tie transmission line pole (approximately 37 poles). Temporary impacts to soils will thereby occur in 1.30 acres within the designated work areas, excluding the area of the transmission poles.

#### **I.4.1 Compaction**

During construction, trucks will drive within the site boundary, but will not likely affect underlying soils due to the physical conditions of the soils. Soils within the site boundary possess qualities that make them inherently resistant to soil compaction. The vast majority of the soils within the site boundary are poorly graded and have loamy sand texture (refer to Table I-1). Moreover, soils within the site boundary are typically dry due to limited precipitation and high permeability.

Soil compaction, which is the increase in soil bulk density as a result of applied loads or pressure, typically alters soil structure and reduces porosity, water infiltration, and root penetration (NRCS 2012). These effects can lead to increased erosion, nutrient loss, reductions in primary productivity, and changes in soil biota, as well as plant species composition. The extent of soil compaction mainly depends on soil conditions as well as the magnitude and frequency of loads/pressures placed upon the soil (Osman 2014). Soils and soil horizons that are well graded (consisting of a mix of different-sized soil particles interspersed with each other), have limited organic matter, and are moist to saturated are generally more susceptible to compaction. Soils that are coarse-grained (loamy sands or coarser), or mainly consist of particles that are very similarly sized, are resistant to compaction (NRCS 2012).

Compaction will not likely cause significant, adverse impacts on soils due to soils within site boundary being inherently resistant to compaction and the implementation of the proposed BMPs and other avoidance and minimization measures described in Section I.5.

#### **I.4.2 Wind Erosion**

Most of the soils within the analysis area are inherently susceptible to high rates of wind erosion, mainly as a result of their sandy texture and limited cover by vegetation (refer to Section I.2.2).

All five soil types belong to WEG 1, which is the group containing the soils that are most easily eroded by wind.

The reduced vegetation cover and potential reduced vegetation vigor (as discussed in Section I.4.4) may exacerbate wind erosion during construction and during the first year or two of Facility operation until vegetation is reestablished. Excavations for roads and trenches will also temporarily expose soils to wind erosion during construction. Vehicle travel in areas may also reduce vegetation cover and destabilize soils, further exposing soils to wind erosion. By the end of construction or soon afterward, grass cover will reestablish in areas of direct soil disturbance activities and thereby reduce the potential for wind erosion to pre-disturbance levels. During operation of the Facility, vehicle traffic and soil disturbance will be much lower than during construction, allowing grasses and other herbaceous vegetation to establish and thrive across most of the Facility site. The solar arrays will also serve as impediments to wind shear strength, further reducing erosion potential. Similar to the construction phase, retirement of the Facility will likely lead to a temporary increase in potential wind erosion from grading and excavation necessary to remove roads, gravel or concrete pads, buried conduits, and other Facility components, and from vegetation mowing and vehicle traffic on areas with unstable soils.

Wind erosion will not likely cause significant, adverse impacts on soils because Applicant will limit the extent of soil disturbance activities and implement an Erosion and Sediment Control Plan (ESCP) and other measures to avoid or minimize the potential for impacts described in Section I.5.

### **I.4.3 Water Erosion**

As with wind erosion, the anticipated reductions in vegetation cover and vigor and increased soil exposure may exacerbate water erosion during construction and during the first year or two of Facility operation. However, the increase in water erosion is likely to be very slight. Although annual precipitation in the analysis area averages approximately 10.4 inches (NRCS 2018), rainfall intensity, the amount of rain that falls over time, is occasionally relatively high. Northern Lake County is in a portion of the state that has some of the highest rainfall intensity (Miller et al. 1973). Intense rainfall events may cause widespread and volumetrically significant erosion, especially in areas with soil types vulnerable to water erosion and/or where vegetation and soils are disturbed by construction, agriculture, or other activities.

Approximately 53 percent of the area in the site boundary is underlain by two types of Morehouse ashy loamy fine sand, both of which have moderate susceptibility to water erosion ( $K_w = 0.28$ ). Another almost 40 percent of the area in the site boundary is underlain by Abert ashy loamy sand, which has moderately low susceptibility to water erosion ( $K_w = 0.2$ ). The remainder of the site boundary is underlain by soil types with very low susceptibility to water erosion ( $K_w = 0.05$  to  $0.1$ ).

Very little water erosion appears to occur on site, as evidenced by the lack of streams, ditches, or water conveyances (refer to Exhibit J for details). When water erosion does occur, it is likely limited in volume and distance traveled, and it likely conveys entrained particles no more than a few feet. In Area A, periodic water erosion events may carry entrained particles to the several hydrologically isolated playas that occur on site.

Given the limited evidence of water erosion at the Facility and the avoidance and minimization measures Applicant will implement (refer to Section I.5), water erosion will not likely cause significant adverse impacts on soils within the site boundary.

#### **I.4.4 Conversion of Existing Vegetation**

During construction, Applicant will mow native vegetation and seed areas of direct soil disturbance with an approved seed mix. Mowing will continue on a periodic basis during operation in some locations.

Within one to two growing seasons after construction is complete, grasses in the site boundary will reestablish. Within 5–10 years, these areas will likely transition to mixed shrubland/grassland with shrub communities dominated by rabbitbrush species (*Chrysothamnus viscidiflorus* and *Ericameria nauseosa*) and possibly other species adapted to early (seral) stages of plant community succession. There will likely be reduced plant vigor (and thereby lower growth rates) during this transition, but overall primary productivity (and vegetation biomass) at the Facility will likely rebound to or even exceed pre-disturbance levels after 5–10 years.

The transition to rabbitbrush shrubland and grassland may increase soil water storage capacity. The prevalence of grasses will result in a thicker layer of decomposed organic matter by concentrating inputs in the upper soil horizons and enabling faster decomposition rates, which will increase nutrient availability. These changes will likely facilitate sustainment by grasses and rabbitbrush.

Some temporary impacts on soils may occur due to the conversion of existing vegetation; however, the Facility will not have significant adverse impacts on soils due to the restoration and subsequent reestablishment of vegetation to rabbitbrush and grassland.

#### **I.4.5 Application of Liquid Effluent**

During construction, water will primarily be sprayed on disturbed areas for dust abatement in accordance with the NPDES 1200-C Construction Stormwater Permit (refer to Appendix I-1). During operation, Applicant will use water without cleaning solvents (soap or detergent) for washing solar panels. Applicant will allow the used water to fall to the ground and infiltrate the soil or evaporate. The panel washing will be covered by and adhere to the conditions of an Oregon General Water Pollution Control Facilities Permit, WPCF-1700-B, Washwater

Discharge from Equipment Cleaning. Application of liquid effluent on soils will not likely cause significant, adverse impacts on soils due to Applicant's adherence to the abovementioned permits and their associated erosion control requirements.

#### **I.4.6 Chemical Spills**

During construction, operation, and retirement of the Facility, potential impacts on soils could result from spills of oil, grease, or other chemicals. Other potentially hazardous substances to be used at the Facility site include household cleansers for the operation and maintenance buildings and pesticides for control of non-native, invasive plants. The construction contractor will prepare and implement a Spill Management Plan (see Appendix I-2 for the draft Spill Management Plan) for the construction, operations, and retirement phases. Refer to Exhibit G for information regarding the handling, storage, and monitoring of chemical or other hazardous materials. Chemicals will be stored at the Facility according to applicable requirements and regulations to limit the potential for spills or any adverse effects related to their use. The risk of a chemical spill is negligible and the impacts of any such spill will be minor due to the small amounts of chemicals planned for use at the Facility.

Given the limited use and storage of chemicals for the Facility and the implementation of a Spill Management Plan, chemical spills will not likely cause significant, adverse impacts on soils in the analysis area.

#### **I.4.7 Noxious Weeds**

During construction, operation, and retirement of the Facility, noxious or other unlisted, non-native invasive weeds could be introduced or spread within the site boundary. The presence of noxious weeds or their seeds is typically considered an adverse impact on soil quality. Noxious weeds are plant species that are non-indigenous and currently injure or have the potential to injure the interests of agriculture and commerce, wildlife resources, or the public health (Federal Noxious Weed Act of 1974 [7 U.S.C. §§2801–2814]). The Oregon Department of Agriculture maintains a State Noxious Weed List to prioritize actions against species with potential to harm resources in the state (ODA 2017). Soils that become infested with noxious weeds or their seeds may be unsuitable for certain uses (e.g., agriculture) without treatment. The seeds or propagules of invasive weeds affixed to tires and undercarriages of construction equipment and vehicles could be transported into the site boundary or spread from one location to another.

It should be noted that no designated noxious weeds were observed during the biological surveys and waters delineation conducted in March and June 2018 (refer to Appendix P-1 for biological surveys results and Appendix J-1 for waters delineation results). However, a few invasive species were observed, including cheatgrass (*Bromus tectorum*). Damage to existing vegetation and



exposure of soils during Facility construction will increase the site's susceptibility to colonization and spread of non-native invasive weeds.

Noxious weeds and other invasive plants species will not likely cause significant, adverse impacts on soils with the implementation of the Revegetation and Noxious Weed Control Plan.

#### **I.4.8 Other Potential Soil Impacts**

Other potential soil impacts include subsidence, frost action, and the presence of shallow rock; however, none of these potential impact types are likely to occur for the reasons described below:

- **Subsidence:** Soil subsidence can damage roads, buildings and other structures. However, none of the soil types in the Facility site have any potential for subsidence due to their coarse texture, low organic matter content, and limited hydrologic inputs.
- **Frost Action:** Frost action can damage roads, buildings, and other structures. However, the soil types within the site boundary have low potential for frost action due to their coarse texture and limited hydrologic inputs.
- **Shallow Rock:** Bedrock or other lithic materials close to the soil surface can prevent the establishment of stable structures. However, the soils within the site boundary are uniformly thick with a depth to bedrock generally greater than 6 feet. (NRCS 2012)

#### **I.5 PROPOSED MEASURES**

**OAR 345-021-0010(1)(i)(D)** *A description of any measures the applicant proposes to avoid or mitigate adverse impact to soils.*

Response: Direct permanent impacts to soils will occur as a result of Facility construction. While unavoidable, they will be minimized whenever possible. For example, of the over 3,921 acres within the site boundary, Applicant plans to avoid more than 200 acres within Area A (refer to Exhibits B and C for details), which will to reduce the impact to soils and other natural resources within the site boundary. In addition, Applicant will limit direct soil disturbance via excavation, clearing, and grading in areas that will be developed during construction to a relatively small area within the site boundary.

During construction, Applicant will implement measures designed to reduce permanent compaction impacts on soils, including, but not limited to, limiting direct soil disturbance to what is required for the safe construction and operation of the Facility, and limiting off-road vehicle traffic to areas within the site boundary. The repetitive and widespread traffic of heavy equipment during construction will likely cause varying degrees of soil compaction throughout the site; however, natural resistance to soil compaction will likely limit the degree of

compaction, except within the areas where roads are constructed. During Facility retirement, Applicant will de-compact and revegetate impacted areas as necessary.

Applicant will minimize the potential for wind erosion by limiting direct soil disturbance (see above), spraying water on exposed areas for dust abatement, limiting the speed of vehicle travel on unpaved surfaces within the site boundary, and re-seeding temporarily disturbed areas. Refer to the summary of BMPs and other impacts avoidance and minimization measures below.

Applicant will minimize the potential impacts from noxious weeds or other invasive plants through the implementation of the Revegetation and Noxious Weed Control Plan (refer to Exhibit P, Appendix P-3), which includes measures such as vehicles and equipment cleaning prior to site boundary entry and requiring any hay bales used for erosion control to be certified weed-free (refer to Section I.5 and Exhibit P, Appendix P-3, for more details about noxious weed prevention).

Applicant will further avoid or minimize impacts on soils by following the requirements of the NPDES 1200-C Construction Stormwater Permit and BMPs described in the ESCP. Applicant developed an ESCP that was submitted to the Oregon Department of Environmental Quality (DEQ) as part of the application for a NPDES permit for construction activities (NPDES 1200-C Construction Stormwater Permit). The ESCP includes BMPs to avoid or minimize erosion, compaction, and sedimentation. Applicant recognizes that updated ESCP drawings may be required once detailed construction plans become available. Refer to Appendix I-1 for the NPDES 1200-C Construction Stormwater Permit application, including the ESCP, a land use compatibility statement, and a letter from the Oregon Department of Environmental Quality confirming receipt of the application, with an estimated date it will complete its review and issue a permit decision. If erosion control measures are not sufficient, this will be identified through routine inspections required by the 1200-C permit in a timely manner, and corrective actions will be implemented promptly.

BMPs and other avoidance or minimization measures provided in the ESCP (refer to Appendix I-1), include, but are not limited to, the following.

- **Limit Disturbance Areas:** Applicant will limit soil disturbance from grading, excavation, drilling, and pile driving solely to what is required for the safe construction and operation of the Facility.
- **Erosion Control BMPs/Measures:** Applicant will use silt fencing, hay bales (certified weed-free), fiber rolls, or other methods to avoid or reduce erosion and sediment transport, as described in the ESCP.
- **Restoration of Temporary Work Areas:** Temporary roads or work areas not otherwise needed for maintenance and operations will be restored to pre-construction conditions, to the extent practicable.

- **Minimize Open Excavations:** Applicant will minimize the amount of time that any excavations remain open and/or unprotected from erosion. Stockpiles, spoils piles, and other unvegetated areas will be covered with erosion-control fabric as necessary.
- **Fugitive Dust Control:** Applicant will control fugitive dust in accordance with DEQ regulations. Water will be sprayed on areas with exposed or de-stabilized soils to suppress wind erosion. As much as is feasible, vehicles will drive on established access roads with stabilized soils. Work will be halted during especially windy times.
- **Spill Management Plan:** Applicant will prepare a Spill Management Plan for the construction, operation, and retirement of the Facility before each phase. Every construction or maintenance crew will carry appropriate emergency spill response equipment, as described in the draft Spill Management Plan (Appendix I-2). If a spill occurs, the crew will temporarily halt work to eliminate the source of the spill, and contain and clean up the material before resuming work.
- **Stabilize Construction Entrance and Exit:** Applicant will stabilize the entrance and exit points for the Facility site to avoid or reduce the soil transport onto paved county roads.

Other measures Applicant may implement to avoid or minimize impacts on soils include, but are not limited to, the following.

- **Speed Limit:** Applicant will impose a 15 mile per hour speed limit within the site boundary to reduce dust emissions, maintain safety, and protect wildlife.
- **Minimize Soil Compaction:** Applicant will minimize compaction of soils and rutting through appropriate use of construction equipment (e.g., low ground-pressure equipment and temporary construction mats).
- **Restrict Refueling and Maintenance Areas:** Applicant will restrict the refueling and maintenance of vehicles and the storage of fuels and hazardous chemicals within at least 100 feet of playas or other waters, and groundwater wells, or as otherwise required by federal, state, or local regulations.
- **Noxious Weed Control:** Applicant will identify, control, and minimize the spread of non-native invasive species and noxious weeds, to the extent practicable, as described in the Revegetation and Noxious Weed Control Plan (included in Exhibit P, Appendix P-3). All vehicles and construction equipment will be cleaned of noxious weed seeds or other plant parts before arriving on the Facility site. Vehicle washing will occur in designated areas within the site boundary only.
- **Soil Decompaction:** During Facility retirement, areas with compacted soils will be decompacted, where feasible, and roughened to provide maximum surface area for seed-soil contact and to reduce the chance of seed loss due to wind.

## **I.6 MONITORING PROGRAM**

**OAR 345-021-0010(1)(i)(E)** *The applicant's proposed monitoring program, if any, for adverse impact to soils during construction and operation.*

Response: Monitoring for the Facility will be performed as required by applicable permits. During construction, erosion and sediment control measures will be visually monitored at the intervals and locations required by the 1200-C permit issued to the Facility. The inspections will verify that BMPs and other applicable measures are being implemented according to ESCP and are effectively minimizing erosion. Inspection reports will be submitted to the DEQ, as required, that describe site conditions, any erosion or sedimentation problems encountered, and any corrective actions taken to resolve the observed problems.

Post-construction soil stabilization monitoring will follow the requirements in the ESCP under the NPDES 1200-C Construction Stormwater Permit and the Facility's Revegetation and Noxious Weed Control Plan (refer to Exhibit P, Appendix P-3). As necessary, Applicant will implement follow-up restoration measures, such as scarification and reseeded, to address remaining impacts. Once the Facility site is determined to be recovered from construction impacts, and that all final stabilization requirements have been met, Applicant will submit a Notice of Termination form to DEQ to close out the NPDES 1200-C Construction Stormwater Permit. Per the Revegetation and Noxious Weed Control Plan, soil stabilization measures will be monitored annually during revegetation monitoring until the Facility meets the revegetation success criteria.

## **I.7 REFERENCES**

Esri. 2019. "World Imagery" [basemap]. Scale Not Given.

<https://www.arcgis.com/home/item.html?id=10df2279f9684e4a9f6a7f08febac2a9>. Accessed October 10, 2019.

Miller, J.F., R.H. Frederick, and R.J. Tracey. 1973. Precipitation-Frequency Atlas of the Western United States. Volume X-Oregon. National Oceanic and Atmospheric Association.

NRCS (Natural Resources Conservation Service). n.d. National Cooperative Soil Survey, Part 622. United States Department of Agriculture.

[https://www.nrcs.usda.gov/wps/portal/nrcs/detail/soils/survey/partnership/nrcs/?cid=nrcs142p2\\_054226](https://www.nrcs.usda.gov/wps/portal/nrcs/detail/soils/survey/partnership/nrcs/?cid=nrcs142p2_054226). Accessed February 5, 2018.

\_\_\_\_\_. 2012. Soil Survey of Lake County, Oregon, Northern Part, Parts of Lake and Klamath Counties. United States Department of Agriculture.

[https://www.nrcs.usda.gov/Internet/FSE\\_MANUSCRIPTS/oregon/lakeOR2012/NLakeOR.pdf](https://www.nrcs.usda.gov/Internet/FSE_MANUSCRIPTS/oregon/lakeOR2012/NLakeOR.pdf). Accessed March 6, 2018.

\_\_\_\_\_. 2007. Part 630 Hydrology National Engineering Handbook. Chapter 7 Hydrologic Soil Groups. United States Department of Agriculture.

<https://directives.sc.egov.usda.gov/OpenNonWebContent.aspx?content=17757.wba>

Accessed May 8, 2018.

\_\_\_\_\_. 2018. AgACIS for Lake County. Monthly Climate Normals (1981-2010) – SILVER LAKE RS, OR. U.S. Department of Agriculture. <http://agacis.rcc-acis.org/?fips=41037>.

Accessed June 19, 2018.

ODA (Oregon Department of Agriculture). 2017. Noxious Weed Policy and Classification System. Noxious Weed Program. Salem, Oregon.

<http://www.oregon.gov/ODA/shared/Documents/Publications/Weeds/NoxiousWeedPolicyClassification.pdf>. Accessed May 17, 2018.

Osman, K.T. 2014. Soil Degradation, Conservation and Remediation. Springer+Business Media. Dordrecht, Germany.

Soil Survey Staff, NRCS (Natural Resources Conservation Service). 2017. Soil Survey Geographic Database (SSURGO). United States Department of Agriculture. Web Soil Survey. <http://websoilsurvey.nrcs.usda.gov/>. Accessed May 9, 2018.



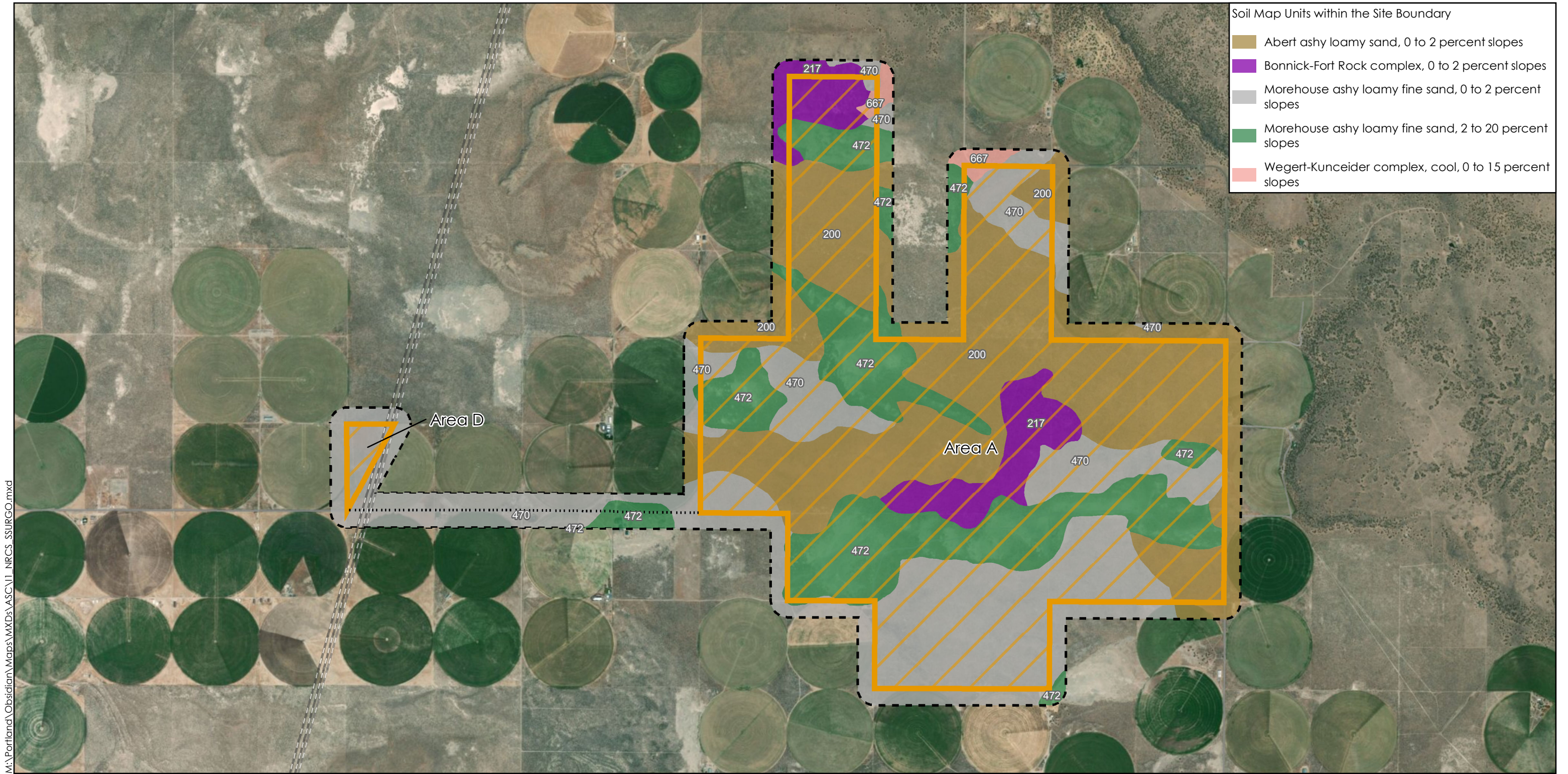

- Soil Map Units within the Site Boundary
- Abert ashy loamy sand, 0 to 2 percent slopes
  - Bonnick-Fort Rock complex, 0 to 2 percent slopes
  - Morehouse ashy loamy fine sand, 0 to 2 percent slopes
  - Morehouse ashy loamy fine sand, 2 to 20 percent slopes
  - Wegert-Kunceider complex, cool, 0 to 15 percent slopes

M:\Portland\Obsidian\Maps\MXD\ASC\11\_NRCS\_SSURGO.mxd



- Site Boundary
- 500-foot Analysis Area
- Gen-tie Transmission Line
- Bonneville Power Administration (500kV)
- PGE Transmission Line (500kV)
- Street

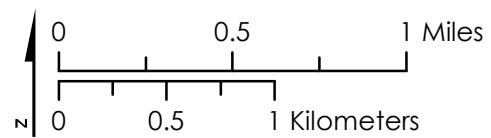

Figure I-1  
Soil Map Units (Soil Types)

**Obsidian Solar Center**

October 2019

Obsidian Solar Center LLC

Sources: Esri 2019; Soil Survey Staff, NRCS 2017





**Appendix I-1**  
**NPDES 1200-C Construction**  
**Stormwater Permit Application and**  
**DEQ Confirmation of Receipt**



**DEQ USE ONLY**

File # \_\_\_\_\_

---

Application # \_\_\_\_\_

LLID/RM: \_\_\_\_\_

River Mile: \_\_\_\_\_

Legal Name Confirmed

Notes: \_\_\_\_\_

---



**DEPARTMENT OF ENVIRONMENTAL QUALITY**

**APPLICATION FOR NEW NPDES GENERAL PERMIT 1200-C**

For stormwater discharges to surface waters from construction activities disturbing one acre or more that do not meet automatic coverage requirements.\*

**DEQ USE ONLY**

Date Received: \_\_\_\_\_

Amount: \$ \_\_\_\_\_

Check # \_\_\_\_\_

Check Name: \_\_\_\_\_

Deposit # \_\_\_\_\_

Receipt # \_\_\_\_\_

Notes: \_\_\_\_\_

---

\*A project *may* be eligible for “automatic coverage” under NPDES general permit 1200-CN if stormwater *does not* discharge to a waterbody with a TMDL or 303(d) listing for sediment or turbidity *and* it meets one of the following criteria (see 1200-CN at <http://www.oregon.gov/deq/FilterPermitsDocs/1200cnPermit.pdf>):

- 1) Disturbs less than one acre and is located in Gresham, Troutdale, or Wood Village.
- 2) Disturbs less than five acres and is located in Albany, Corvallis, Eugene, Milwaukie, Multnomah Co. (unincorporated areas), Springfield, West Linn, or Wilsonville.
- 3) Disturbs less than five acres and is within the jurisdictions of Clackamas Co. Water Environment Services [Gladstone, areas within Clackamas Co. Service Dist. #1 (excluding Happy Valley), and areas within the Surface Water Management Agency of Clackamas Co. (including Rivergrove)], Clean Water Services (Banks, Beaverton, Cornelius, Durham, Forest Grove, Hillsboro, King City, North Plains, Sherwood, Tigard, Tualatin, and Washington Co. within Urban Growth Boundary), or Rogue Valley Sewer Services.

A. PROJECT INFORMATION	
<p>1. <u>Obsidian Solar Center LLC</u> Applicant (entity legally responsible for permit)</p> <p><u>Michelle Slater</u> Contact Name (if different from applicant)</p> <p><u>5 Centerpointe Drive Suite 250</u> Address</p> <p><u>Lake Oswego</u>      <u>Oregon</u>      <u>97035</u> City                      State                      Zip</p> <p><u>(503) 245-8800</u>      <u>m Slater@obsidianrenewables.com</u> Telephone                      E-Mail Address</p>	<p>2. Invoicing information (person or entity legally responsible for payment of annual fee invoice; not a third party independent of the applicant)</p> <p>_____ Invoice Contact Name (if different from applicant)</p> <p>_____ Address</p> <p>_____ City                      State                      Zip</p> <p>_____ Telephone                      E-Mail Address</p>
<p>3. <u>Michael Baker International</u> Architect/Engineering Firm (Erosion &amp; Sediment Control Plan)</p> <p><u>Scott Davis</u> Project Manager</p> <p><u>(858) 614-5043</u>      <u>scottdavis@mbakerintl.com</u> Telephone                      E-Mail Address</p>	<p>4. _____ Applicant's Designated Erosion and Sediment Control Inspector</p> <p><u>Maren, Fulton, Ecology and Environment, Inc.</u> Company Name</p> <p><u>(503) 248-5600</u>      <u>mfulton@ene.com</u> Telephone                      E-Mail Address</p> <p>Certified by Building Industry Association of Washington CESCL ID #47030, valid through 3/22/20 Qualification program, certification number and expiration date</p>

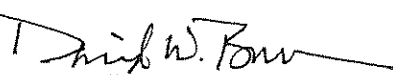
<p>5. <u>Obsidian Solar Center</u>  Name of Project  <u>County Road 5-14 G (Oil Dri Road)</u>  Address or Cross Street  <u>(near Fort Rock) Oregon 97638</u>  City State Zip  <u>Lake County</u>  County</p>	<p>6. Nature of Construction Activity  <input type="checkbox"/> Single Family (SIC Code 1521)  <input type="checkbox"/> Multi-Family Residential (SIC Code 1522)  <input type="checkbox"/> Commercial (SIC Code 1542)  <input type="checkbox"/> Industrial (SIC Code 1541)  <input type="checkbox"/> Highway (SIC Code 1611)  <input type="checkbox"/> Restoration (SIC Code 1629)  <input checked="" type="checkbox"/> Utilities (SIC Code 1623): <u>solar panel arrays/power generation</u>  <input type="checkbox"/> Other (SIC Code required): _____  Army Corps No. (if any): _____</p>
<p>7. Approximate location of center of site  Latitude: <u>43.307998</u> Longitude: <u>-120.799289</u>  **For assistance: DEQ Location Improvement Tool at:  <a href="http://deqapp1/website/lit/data.asp">http://deqapp1/website/lit/data.asp</a>**</p>	<p>8. Approximate start date: <u>December 2019</u>  Project Size  Total Site Acreage (acres): <u>4200</u>  Total Disturbed Area (acres): <u>4200</u>  Total Number of Lots: <u>10</u></p>
<p>9. Is there soil or groundwater contamination located within the site boundary? <input type="checkbox"/> YES <input checked="" type="checkbox"/> NO  Will you be dewatering during construction (plan review fee may apply)? <input type="checkbox"/> YES <input checked="" type="checkbox"/> NO  Depth to groundwater: _____ Data Source: _____</p>	
<p>10. Receiving waterbody - Must identify final discharge location of construction stormwater flows.  <input checked="" type="checkbox"/> Waters of the State (name or description): <u>various playas and playa mosaics</u>  <input type="checkbox"/> Municipal storm sewer or drainage system (include downstream receiving waterbody):  <input type="checkbox"/> Ditch (include downstream receiving waterbody):  <input type="checkbox"/> Irrigation channel or ditch (include owner or operator):  <input type="checkbox"/> Infiltration device(s) (construction stormwater discharge to underground injection control/drywell is prohibited)  <input checked="" type="checkbox"/> Other: <u>most of the water will be used for dust control on relatively flat site and will infiltrate into the soil or evaporate</u></p>	
<p>11. Stormwater runoff during construction discharges directly to or through a storm sewer or drainage system that discharges to a waterbody with a Total Maximum Daily Load (TMDL) or 303(d) listing for turbidity or sedimentation? <input type="checkbox"/> YES <input checked="" type="checkbox"/> NO  **For assistance: DEQ assessment database page at <a href="http://www.deq.state.or.us/wq/assessment/rpt2012/search.asp">http://www.deq.state.or.us/wq/assessment/rpt2012/search.asp</a></p>	
<p><b>B. SIGNATURE OF LEGALLY AUTHORIZED REPRESENTATIVE</b></p>	
<p>The legally authorized representative <i>must</i> sign the application (see instructions – Section C).  I hereby certify that the information contained in this application is true and correct to the best of my knowledge and belief. In addition, I agree to pay all permit fees required by Oregon Administrative Rules 340-045. This includes a compliance determination fee invoiced annually by DEQ to maintain the permit.</p>	
<p><u>David W. Brown</u>  Name of Legally Authorized Representative (Type or Print)</p>	<p><u>Manager</u>  Title</p>
<p>  Signature of Legally Authorized Representative</p>	<p><u>August 16, 2018</u>  Date</p>

**STANDARD EROSION AND SEDIMENT CONTROL PLAN DRAWING NOTES:**

- HOLD A PRE-CONSTRUCTION MEETING OF PROJECT CONSTRUCTION PERSONNEL THAT INCLUDES THE INSPECTOR TO DISCUSS EROSION AND SEDIMENT CONTROL MEASURES AND CONSTRUCTION LIMITS. (SCHEDULE A.8.C.I.(3))
- ALL INSPECTIONS MUST BE MADE IN ACCORDANCE WITH DEQ 1200-C PERMIT REQUIREMENTS. (SCHEDULE A.12.B AND SCHEDULE B.1)
- INSPECTION LOGS MUST BE KEPT IN ACCORDANCE WITH DEQ'S 1200-C PERMIT REQUIREMENTS. (SCHEDULE B.1.C AND B.2)
- RETAIN A COPY OF THE ESCP AND ALL REVISIONS ON SITE AND MAKE IT AVAILABLE ON REQUEST TO DEQ, AGENT, OR THE LOCAL MUNICIPALITY. DURING INACTIVE PERIODS OF GREATER THAN SEVEN (7) CONSECUTIVE CALENDAR DAYS, THE ABOVE RECORDS MUST BE RETAINED BY THE PERMIT REGISTRANT BUT DO NOT NEED TO BE AT THE CONSTRUCTION SITE. (SCHEDULE B.2.C)
- ALL PERMIT REGISTRANTS MUST IMPLEMENT THE ESCP. FAILURE TO IMPLEMENT ANY OF THE CONTROL MEASURES OR PRACTICES DESCRIBED IN THE ESCP IS A VIOLATION OF THE PERMIT. (SCHEDULE A.8.A)
- THE ESCP MUST BE ACCURATE AND REFLECT SITE CONDITIONS. (SCHEDULE A.12.C.I)
- SUBMISSION OF ALL ESCP REVISIONS IS NOT REQUIRED. SUBMITTAL OF THE ESCP REVISIONS IS ONLY UNDER SPECIFIC CONDITIONS. SUBMIT ALL NECESSARY REVISION TO DEQ OR AGENT WITHIN 10 DAYS. (SCHEDULE A.12.C.IV. AND V)
- PHASE CLEARING AND GRADING TO THE MAXIMUM EXTENT PRACTICAL TO PREVENT EXPOSED INACTIVE AREAS FROM BECOMING A SOURCE OF EROSION. (SCHEDULE A.7.A.III)
- IDENTIFY, MARK, AND PROTECT (BY CONSTRUCTION FENCING OR OTHER MEANS) CRITICAL RIPARIAN AREAS AND VEGETATION INCLUDING IMPORTANT TREES AND ASSOCIATED ROOTING ZONES, AND VEGETATION AREAS TO BE PRESERVED. IDENTIFY VEGETATIVE BUFFER ZONES BETWEEN THE SITE AND SENSITIVE AREAS (E.G., WETLANDS), AND OTHER AREAS TO BE PRESERVED, ESPECIALLY IN PERIMETER AREAS. (SCHEDULE A.8.C.I.(1) AND (2))
- PRESERVE EXISTING VEGETATION WHEN PRACTICAL AND RE-VEGETATE OPEN AREAS. RE-VEGETATE OPEN AREAS WHEN PRACTICABLE BEFORE AND AFTER GRADING OR CONSTRUCTION. IDENTIFY THE TYPE OF VEGETATIVE SEED MIX USED. (SCHEDULE A.7.A.V)
- MAINTAIN AND DELINEATE ANY EXISTING NATURAL BUFFER WITHIN THE 50-FOOT OF WATERS OF THE STATE. (SCHEDULE A.7.B.I AND (2)(A)(B))
- INSTALL PERIMETER SEDIMENT CONTROL, INCLUDING STORM DRAIN INLET PROTECTION AS WELL AS ALL SEDIMENT BASINS, TRAPS, AND BARRIERS PRIOR TO LAND DISTURBANCE. (SCHEDULE A.8.C.I.(5))
- CONTROL BOTH PEAK FLOW RATES AND TOTAL STORMWATER VOLUME, TO MINIMIZE EROSION AT OUTLETS AND DOWNSTREAM CHANNELS AND STREAMBANKS. (SCHEDULE A.7.C)
- CONTROL SEDIMENT AS NEEDED ALONG THE SITE PERIMETER AND AT ALL OPERATIONAL INTERNAL STORM DRAIN INLETS AT ALL TIMES DURING CONSTRUCTION, BOTH INTERNALLY AND AT THE SITE BOUNDARY. (SCHEDULE A.7.D.I)
- ESTABLISH CONCRETE TRUCK AND OTHER CONCRETE EQUIPMENT WASHOUT AREAS BEFORE BEGINNING CONCRETE WORK. (SCHEDULE A.8.C.I.(6))
- APPLY TEMPORARY AND/OR PERMANENT SOIL STABILIZATION MEASURES IMMEDIATELY ON ALL DISTURBED AREAS AS GRADING PROGRESSES. TEMPORARY OR PERMANENT STABILIZATION MEASURES ARE NOT REQUIRED FOR AREAS THAT ARE INTENDED TO BE LEFT UNVEGETATED, SUCH AS DIRT ACCESS ROADS OR UTILITY POLE PADS. (SCHEDULE A.8.C.II.(3))
- ESTABLISH MATERIAL AND WASTE STORAGE AREAS, AND OTHER NON-STORMWATER CONTROLS. (SCHEDULE A.8.C.I.(7))
- PREVENT TRACKING OF SEDIMENT ONTO PUBLIC OR PRIVATE ROADS USING BMPs SUCH AS: CONSTRUCTION ENTRANCE, GRAVELED (OR PAVED) EXITS AND PARKING AREAS, GRAVEL ALL UNPAVED ROADS LOCATED ONSITE, OR USE AN EXIT TIRE WASH. THESE BMPs MUST BE IN PLACE PRIOR TO LAND-DISTURBING ACTIVITIES. (SCHEDULE A.7.D.II AND A.8.C.I(4))
- WHEN TRUCKING SATURATED SOILS FROM THE SITE, EITHER USE WATER-TIGHT TRUCKS OR DRAIN LOADS ON SITE. (SCHEDULE A.7.D.II.(5))
- CONTROL PROHIBITED DISCHARGES FROM LEAVING THE CONSTRUCTION SITE, I.E., CONCRETE WASH-OUT, WASTEWATER FROM CLEANOUT OF STUCCO, PAINT AND CURING COMPOUNDS. (SCHEDULE A.6)
- USE BMPs TO PREVENT OR MINIMIZE STORMWATER EXPOSURE TO POLLUTANTS FROM SPILLS; VEHICLE AND EQUIPMENT FUELING, MAINTENANCE, AND STORAGE; OTHER CLEANING AND MAINTENANCE ACTIVITIES; AND WASTE HANDLING ACTIVITIES. THESE POLLUTANTS INCLUDE FUEL, HYDRAULIC FLUID, AND OTHER OILS FROM VEHICLES AND MACHINERY, AS WELL AS DEBRIS, FERTILIZERS, PESTICIDES AND HERBICIDES, PAINTS, SOLVENTS, CURING COMPOUNDS AND ADHESIVES FROM CONSTRUCTION OPERATIONS. (SCHEDULE A.7.E.I.(2))
- IMPLEMENT THE FOLLOWING BMPs WHEN APPLICABLE: WRITTEN SPILL PREVENTION AND RESPONSE PROCEDURES, EMPLOYEE TRAINING ON SPILL PREVENTION AND PROPER DISPOSAL PROCEDURES, SPILL KITS IN ALL VEHICLES, REGULAR MAINTENANCE SCHEDULE FOR VEHICLES AND MACHINERY, MATERIAL DELIVERY AND STORAGE CONTROLS, TRAINING AND SIGNAGE, AND COVERED STORAGE AREAS FOR WASTE AND SUPPLIES. (SCHEDULE A.7.E.III.)
- USE WATER, SOIL-BINDING AGENT OR OTHER DUST CONTROL TECHNIQUE AS NEEDED TO AVOID WIND-BLOWN SOIL. (SCHEDULE A.7.A.IV)
- THE APPLICATION RATE OF FERTILIZERS USED TO REESTABLISH VEGETATION MUST FOLLOW MANUFACTURER'S RECOMMENDATIONS TO MINIMIZE NUTRIENT RELEASES TO SURFACE WATERS. EXERCISE CAUTION WHEN USING TIME-RELEASE FERTILIZERS WITHIN ANY WATERWAY RIPARIAN ZONE. (SCHEDULE A.9.B.III)
- IF AN ACTIVE TREATMENT SYSTEM (FOR EXAMPLE, ELECTRO-COAGULATION, FLOCCULATION, FILTRATION, ETC.) FOR SEDIMENT OR OTHER POLLUTANT REMOVAL IS EMPLOYED, SUBMIT AN OPERATION AND MAINTENANCE PLAN (INCLUDING SYSTEM SCHEMATIC, LOCATION OF SYSTEM, LOCATION OF INLET, LOCATION OF DISCHARGE, DISCHARGE DISPERSION DEVICE DESIGN, AND A SAMPLING PLAN AND FREQUENCY) BEFORE OPERATING THE TREATMENT SYSTEM. OBTAIN PLAN APPROVAL BEFORE OPERATING THE TREATMENT SYSTEM. OPERATE AND MAINTAIN THE TREATMENT SYSTEM ACCORDING TO MANUFACTURER'S SPECIFICATIONS. (SCHEDULE A.9.D)
- TEMPORARILY STABILIZE SOILS AT THE END OF THE SHIFT BEFORE HOLIDAYS AND WEEKENDS, IF NEEDED. THE REGISTRANT IS RESPONSIBLE FOR ENSURING THAT SOILS ARE STABLE DURING RAIN EVENTS AT ALL TIMES OF THE YEAR. (SCHEDULE A.7.B)
- AS NEEDED BASED ON WEATHER CONDITIONS, AT THE END OF EACH WORKDAY SOIL STOCKPILES MUST BE STABILIZED OR COVERED, OR OTHER BMPs MUST BE IMPLEMENTED TO PREVENT DISCHARGES TO SURFACE WATERS OR CONVEYANCE SYSTEMS LEADING TO SURFACE WATERS. (SCHEDULE A.7.E.II.(2))
- CONSTRUCTION ACTIVITIES MUST AVOID OR MINIMIZE EXCAVATION AND BARE GROUND ACTIVITIES DURING WET WEATHER. (SCHEDULE A.7.A.I)
- SEDIMENT FENCE: REMOVE TRAPPED SEDIMENT BEFORE IT REACHES ONE THIRD OF THE ABOVE GROUND FENCE HEIGHT AND BEFORE FENCE REMOVAL. (SCHEDULE A.9.C.I)
- OTHER SEDIMENT BARRIERS (SUCH AS BIOBAGS): REMOVE SEDIMENT BEFORE IT REACHES TWO INCHES DEPTH ABOVE GROUND HEIGHT AND BEFORE BMP REMOVAL. (SCHEDULE A.9.C.I)
- CATCH BASINS: CLEAN BEFORE RETENTION CAPACITY HAS BEEN REDUCED BY FIFTY PERCENT. SEDIMENT BASINS AND SEDIMENT TRAPS: REMOVE TRAPPED SEDIMENTS BEFORE DESIGN CAPACITY HAS BEEN REDUCED BY FIFTY PERCENT AND AT COMPLETION OF PROJECT. (SCHEDULE A.9.C.III & IV)
- WITHIN 24 HOURS, SIGNIFICANT SEDIMENT THAT HAS LEFT THE CONSTRUCTION SITE, MUST BE REMEDIATED. INVESTIGATE THE CAUSE OF THE SEDIMENT RELEASE AND IMPLEMENT STEPS TO PREVENT A RECURRENCE OF THE DISCHARGE WITHIN THE SAME 24 HOURS. ANY IN-STREAM CLEAN-UP OF SEDIMENT SHALL BE PERFORMED ACCORDING TO THE OREGON DIVISION OF STATE LANDS REQUIRED TIMEFRAME. (SCHEDULE A.9.B.I)
- THE INTENTIONAL WASHING OF SEDIMENT INTO STORM SEWERS OR DRAINAGE WAYS MUST NOT OCCUR. VACUUMING OR DRY SWEEPING AND MATERIAL PICKUP MUST BE USED TO CLEANUP RELEASED SEDIMENTS. (SCHEDULE A.9.B.II)
- THE ENTIRE SITE MUST BE TEMPORARILY STABILIZED USING VEGETATION OR A HEAVY MULCH LAYER, TEMPORARY SEEDING, OR OTHER METHOD SHOULD ALL CONSTRUCTION ACTIVITIES CEASE FOR 30 DAYS OR MORE. (SCHEDULE A.7.F.I)
- PROVIDE TEMPORARY STABILIZATION FOR THAT PORTION OF THE SITE WHERE CONSTRUCTION ACTIVITIES CEASE FOR 14 DAYS OR MORE WITH A COVERING OF BLOWN STRAW AND A TACKIFIER, LOOSE STRAW, OR AN ADEQUATE COVERING OF COMPOST MULCH UNTIL WORK RESUMES ON THAT PORTION OF THE SITE. (SCHEDULE A.7.F.II)
- DO NOT REMOVE TEMPORARY SEDIMENT CONTROL PRACTICES UNTIL PERMANENT VEGETATION OR OTHER COVER OF EXPOSED AREAS IS ESTABLISHED. ONCE CONSTRUCTION IS COMPLETE AND THE SITE IS STABILIZED, ALL TEMPORARY EROSION CONTROLS AND RETAINED SOILS MUST BE REMOVED AND DISPOSED OF PROPERLY, UNLESS DOING SO CONFLICTS WITH LOCAL REQUIREMENTS. (SCHEDULE A.8.C.III(1) AND D.3.C.II AND III)

# EROSION AND SEDIMENT CONTROL PLAN

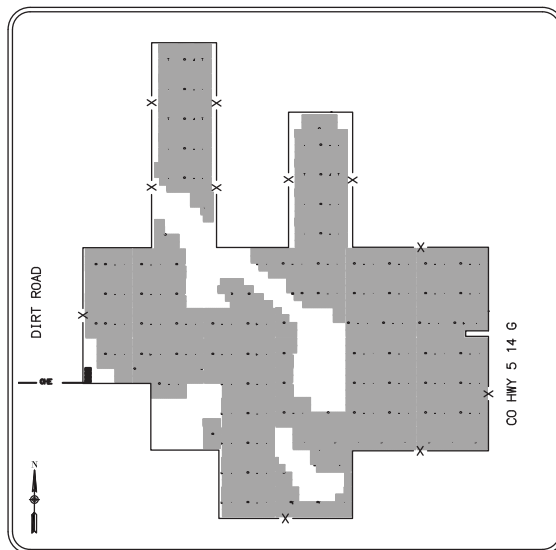

**SITE MAP**  
N.T.S

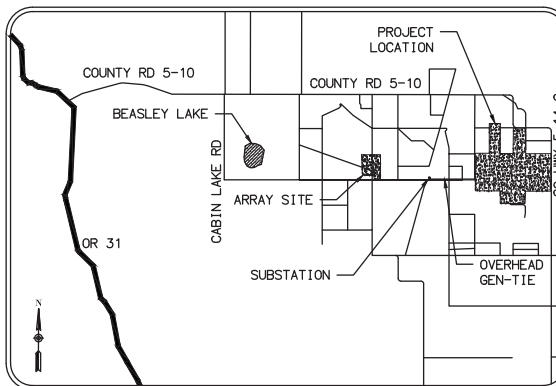

**VICINITY MAP**  
N.T.S

**PROPERTY DESCRIPTION:**

TAX LOTS 2702,2708,4600,5800 LAKE COUNTY TAX MAP 26 16  
 LOCATED IN THE SOUTH 1/2 OF SECTION 16, TOWNSHIP 26 SOUTH, RANGE 16 EAST, WILLAMETTE MERIDAN, LAKE COUNTY, OREGON

**PROJECT LOCATION:**

NEAR THE TOWN OF FORT ROCK, 2.0 MILES EAST OF FORT ROCK ROAD, 2.0 MILES NORTH OF SALT FLAT LANE, DIRECTLY WEST OF COUNTRY HW 5-14G.

LATITUDE = N43°18'38.01" LONGITUDE = W120°49'45.35"

- HOLD A PRE-CON MEETING OF PROJECT CONSTRUCTION PERSONNEL THAT INCLUDES THE EC INSPECTOR
- ALL INSPECTIONS MUST BE MADE IN ACCORDANCE WITH DEQ 1200C PERMIT REQUIREMENTS
- INSPECTION LOGS MUST BE KEPT IN ACCORDANCE WITH DEQ 1200C PERMIT REQUIREMENTS
- REVISIONS TO THE APPROVED ESC PLAN MUST BE SUBMITTED TO DEQ OR AGENT IN ACCORDANCE WITH CURRENT 1200C PERMIT

**RATIONALE STATEMENT**

A COMPREHENSIVE LIST OF AVAILABLE BEST MANAGEMENT PRACTICES (BMP) OPTIONS BASED ON DEQ'S GUIDANCE MANUAL HAS BEEN REVIEWED TO COMPLETE THIS EROSION AND SEDIMENT CONTROL PLAN. SOME OF THE ABOVE LISTED BMP'S WERE NOT CHOSEN BECAUSE THEY WERE DETERMINED TO NOT EFFECTIVELY MANAGE EROSION PREVENTION AND SEDIMENT CONTROL FOR THIS PROJECT BASED ON SPECIFIC SITE CONDITIONS, INCLUDING SOIL CONDITIONS, TOPOGRAPHIC CONSTRAINTS, ACCESSIBILITY TO THE SITE, AND OTHER RELATED CONDITIONS, AS THE PROJECT PROGRESSES AND THERE IS A NEED TO REVISE THE ESC PLAN, AN ACTION PLAN WILL BE SUBMITTED.

**DEVELOPER**

DEVELOPER/COMPANY: OBSIDIAN SOLAR CENTER, LLC  
 CONTACT: MICHELLE SLATER  
 5 CENTERPOINTE DRIVE #250  
 LAKE OSWEGO, OR 97035  
 PHONE: 503-488-6153

**CONTRACTOR**

SWINTERTON BUILDERS  
 CONTACT: DONNY GALLAGHER  
 16798 WEST BERNARDO DRIVE  
 SAN DIEGO, CA 92127  
 PHONE: 858-229-5774

**ENGINEERING**

MICHAEL BAKER INTERNATIONAL  
 CONTACT: SCOTT DAVIS  
 9755 CLAIREMONT MESA BLVD  
 SAN DIEGO, CA 92128  
 PHONE: 858-229-5774

**NARRATIVE DESCRIPTIONS**

**EXISTING SITE CONDITIONS**

UNDEVELOPED LAND

**DEVELOPED CONDITIONS**

SOLAR PANEL ARRAYS

**NATURE OF CONSTRUCTION ACTIVITY AND ESTIMATED TIME TABLE**

- CLEARING (TBD)
- GRADING (TBD)
- UTILITY INSTALLATION (TBD)
- SITE IMPROVEMENT CONSTRUCTION (TBD)
- FINAL STABILIZATION (TBD)

TOTAL SITE AREA = 3520 ACRES

TOTAL DISTURBED AREA = 3520 ACRES

**SITE SOIL CLASSIFICATION**

- 200 - ABERT ASHY LOAM SAND, 0 TO 2 PERCENT SLOPES
- 217 - BONNICH-FORT ROCK COMPLEX, 0 TO 2 PERCENT SLOPES
- 470 - MOREHOUSE ASHY LOAM FINE SAND, 0 TO 2 PERCENT SLOPES
- 472 - MOREHOUSE ASHY LOAM FINE SAND, 0 TO 20 PERCENT SLOPES

ON-SITE SOILS HAVE A MODERATE TO HIGH EROSION POTENTIAL. ALL FILL MATERIAL SHALL BE GENERATED ON-SITE FROM GRADING EXCAVATION AND UTILITY TRENCH SOILS

IMPORTED MATERIAL FOR ROADWAY WILL CONSIST OF ROAD SPECIFIED 3"-MINUS AND 3/4"-MINUS GRAVEL

**RECEIVING WATER BODIES**

NEAREST WATER BODY: BEASLEY LAKE

**PERMITTEE'S SITE INSPECTOR:** MAREN FULTON

COMPANY/AGENCY: ECOLOGY & ENVIRONMENT, INC

PHONE: (503) 248-5600

FAX: N/A

E-MAIL: MFULTON@ENE.COM

DESCRIPTION OF EXPERIENCE: \_\_\_\_\_

**INSPECTION FREQUENCY:**

SITE CONDITIONS	MINIMUM FREQUENCY
1. ACTIVE PERIOD	DAILY WHEN STORMWATER RUNOFF, INCLUDING RUNOFF FROM SNOWMELT, IS OCCURRING.  AT LEAST ONCE EVERY TWO (2) WEEKS REGARDLESS OF WHETHER STORMWATER RUNOFF IS OCCURRING.
2. PRIOR TO THE SITE BECOMING INACTIVE OR IN ANTICIPATION OF SITE INACCESSIBILITY.	ONCE TO ENSURE THAT EROSION AND SEDIMENT MEASURES ARE IN WORKING ORDER. ANY NECESSARY MAINTENANCE AND REPAIR MUST BE MADE PRIOR TO LEAVING THE SITE.
3. INACTIVE PERIODS GREATER THAN FOURTEEN (14) CONSECUTIVE CALENDER DAYS.	ONCE EVERY TWO (2) WEEKS.
4. PERIODS DURING WHICH THE SITE IS INACCESSIBLE DUE TO INCLEMENT WEATHER.	IF PRACTICAL, INSPECTIONS MUST OCCUR DAILY AT A RELEVANT AND ACCESSIBLE DISCHARGE POINT OR DOWNSTREAM LOCATION
5. PERIODS DURING WHICH DISCHARGE IS UNLIKELY DUE TO FROZEN CONDITIONS.	MONTHLY. RESUME MONITORING IMMEDIATELY UPON MELT, OR WHEN WEATHER CONDITIONS MAKE DISCHARGE UNLIKELY.

**BMP MATRIX FOR CONSTRUCTION PHASING**

REFER TO DEQ GUIDANCE MANUAL FOR A COMPREHENSIVE LIST OF AVAILABLE BMP'S

	CLEARING	MASS GRADING	UTILITY INSTALLATION	STREET CONSTRUCTION	FINAL STABILIZATION	WET WEATHER (OCT.1-MAY 31)
<b>EROSION PREVENTION</b>						
PRESERVE NATURAL VEGETATION	X		X	X		X
GROUND COVER					X	X
HYDRAULIC APPLICATIONS					X	
PLASTIC SHEETING					X	
MATTING					X	
DUST CONTROL	X		X	X		X
TEMPORARY/PERMANENT SEEDING			X	X	X	X
BUFFER ZONE					X	
OTHER:						
<b>SEDIMENT CONTROL</b>						
SEDIMENT FENCE (PERIMETER)			X	X		
SEDIMENT FENCE (INTERIOR)			X	X		
STRAW WATTLES	X		X	X	X	X
FILTER BERM			X	X		
INLET PROTECTION			X	X		
DEWATERING			X	X		
SEDIMENT TRAP			X	X		
OTHER:						
<b>RUN OFF CONTROL</b>						
CONSTRUCTION ENTRANCE	X		X	X		X
PIPE SLOPE DRAIN					X	
OUTLET PROTECTION			X	X	X	
SURFACE ROUGHENING					X	
CHECK DAMS					X	
OTHER:						
<b>POLLUTION PREVENTION</b>						
PROPER SIGNAGE	X		X	X	X	X
HAZ WASTE MGMT	X		X	X	X	X
SPILL KIT ON-SITE	X		X	X	X	X
CONCRETE WASHOUT AREA	X		X	X	X	X
OTHER:						

**LOCAL AGENCY-SPECIFIC EROSION CONTROL NOTES:**

- OWNER OR DESIGNATED PERSON SHALL BE RESPONSIBLE FOR PROPER INSTALLATION AND MAINTENANCE OF ALL EROSION AND SEDIMENT CONTROL MEASURES, IN ACCORDANCE WITH LOCAL, STATE, AND FEDERAL REGULATIONS.
- PRIOR TO ANY LAND DISTURBING ACTIVITIES, THE BOUNDARIES OF THE CLEARING LIMITS, VEGETATED BUFFERS, AND ANY SENSITIVE AREAS SHOWN ON THIS PLAN SHALL BE CLEARLY DELINEATED IN THE FIELD. DURING THE CONSTRUCTION PERIOD, NO DISTURBANCE IS PERMITTED BEYOND THE CLEARING LIMITS. THE OWNER/PERMITTEE MUST MAINTAIN THE DELINEATION FOR THE DURATION OF THE PROJECT. THE OWNER IS REQUIRED TO DELINEATE ANY PLAYS ON SITE. NOTE: VEGETATED CORRIDORS TO BE DELINEATED WITH ORANGE CONSTRUCTION FENCE OR APPROVED EQUAL.
- PRIOR TO ANY LAND DISTURBING ACTIVITIES, THE BMP'S THAT MUST BE INSTALLED ARE GRAVEL CONSTRUCTION ENTRANCE, PERIMETER SEDIMENT CONTROL, AND INLET PROTECTION. THESE BMP'S MUST BE MAINTAINED FOR THE DURATION OF THE PROJECT.
- IF VEGETATIVE SEED MIXES ARE SPECIFIED, SEEDING MUST TAKE PLACE NO LATER THAN SEPTEMBER 1; THE TYPE AND PERCENTAGES OF SEED IN THE MIX MUST BE IDENTIFIED ON THE PLANS
- ALL PUMPING OF SEDIMENT LADEN WATER SHALL BE DISCHARGED OVER AN UNDISTURBED, PREFERABLY VEGETATED AREA, AND THROUGH A SEDIMENT CONTROL BMP I.E. (FILTER BAG)
- THE ESC PLAN MUST BE KEPT ON SITE. ALL MEASURES SHOWN ON THE PLAN MUST BE INSTALLED PROPERLY TO ENSURE THAT SEDIMENT OR SEDIMENT LADEN WATER DOES NOT ENTER A SURFACE WATER SYSTEM, ROADWAY, OR OTHER PROPERTIES.
- THE ESCP MEASURES SHOWN ON THIS PLAN ARE MINIMUM REQUIREMENTS FOR ANTICIPATED SITE CONDITIONS. DURING THE CONSTRUCTION PERIOD, THESE MEASURES SHALL BE UPGRADED AS NEEDED TO COMPLY WITH ALL APPLICABLE LOCAL, STATE, AND FEDERAL EROSION CONTROL REGULATIONS. CHANGES TO THE APPROVED ESC PLAN MUST BE SUBMITTED IN THE FORM OF AN ACTION PLAN TO DEQ PER THE 1200C PERMIT.
- IN AREAS SUBJECT TO WIND EROSION, APPROPRIATE BMP'S MUST BE USED WHICH MAY INCLUDE THE APPLICATION OF FINE WATER SPRAYING, PLASTIC SHEETING, MULCHING, OR OTHER APPROVED MEASURES.
- ALL EXPOSED SOIL MUST BE COVERED DURING THE WET WEATHER PERIOD.

THE PERMITTEE IS REQUIRED TO MEET ALL THE CONDITIONS OF THE 1200C PERMIT. THIS ESCP AND GENERAL CONDITIONS HAVE BEEN DEVELOPED TO FACILITATE COMPLIANCE WITH THE 1200C PERMIT REQUIREMENTS. IN CASES OF DISCREPANCIES OR OMISSIONS, THE 1200C PERMIT REQUIREMENTS SUPERCEDE REQUIREMENTS OF THIS PLAN

**ATTENTION EXCAVATORS:**

OREGON LAW REQUIRES YOU TO FOLLOW RULES ADOPTED BY THE OREGON UTILITY NOTIFICATION CENTER. THOSE RULES ARE SET FORTH IN OUR 952-001-0010 THROUGH 952-001-0090. YOU MAY OBTAIN COPIES OF THESE RULES FROM THE CENTER BY CALLING 1-800-332-2344. IF YOU HAVE ANY QUESTIONS ABOUT THE RULES, YOU MAY CONTACT THE CENTER. YOU MUST NOTIFY THE CENTER AT LEAST TWO BUSINESS DAYS, BEFORE COMMENCING ANY EXCAVATION. CALL 1-800-332-2344.

**PRELIMINARY NOT FOR CONSTRUCTION**

REVISIONS:

**EROSION AND SEDIMENT CONTROL COVER SHEET**

**Michael Baker INTERNATIONAL**  
 9755 Clairemont Mesa Blvd., San Diego, CA 92124  
 Phone: (858) 614-5000 • MBAKERINTL.COM

DESIGNED BY: JM DRAWING NO.: 168058  
 DRAWN BY: JM SCALE: AS NOTED  
 CHECKED BY: ST  
 PREPARED FOR: SWINTERTON BUILDERS  
 16798 WEST BERNARDO DRIVE  
 SAN DIEGO, CA 92127  
 PHONE: 858-229-5774

**OBSIDIAN SOLAR CENTER**  
**FORT ROCK OREGON**  
 TAX LOTS 2702, 2708, 4600, 5800 LAKE COUNTY TAX MAP 26 16

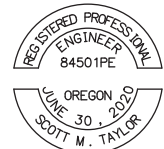

JOB NUMBER  
 SHEET  
**EC-1**

INITIAL

**PRE-CONSTRUCTION, CLEARING, AND DEMOLITION NOTES:**

1. ALL BASE ESCP MEASURES (INLET PROTECTION, PERIMETER SEDIMENT CONTROL, GRAVEL CONSTRUCTION ENTRANCES, ECT) MUST BE IN PLACE, FUNCTIONAL, AND APPROVED IN AN INITIAL INSPECTION, PRIOR TO COMMENCEMENT OF CONSTRUCTION ACTIVITIES.
2. SEDIMENT BARRIERS APPROVED FOR USE INCLUDE SEDIMENT FENCE, BERMS CONSTRUCTED OUT OF MULCH, CHIPPINGS, OR OTHER SUITABLE MATERIAL, STRAW WATTLES, OR OTHER APPROVED MATERIALS.
3. SENSITIVE RESOURCES INCLUDING, BUT NOT LIMITED TO, TREES, PLAYAS, AND RIPARIAN PROTECTION AREAS SHALL BE CLEARLY DELINEATED 10 FEET OUTSIDE THESE AREAS WITH ORANGE CONSTRUCTION FENCING OR CHAIN LINK FENCING IN A MANNER THAT IS CLEARLY VISIBLE TO ANYONE IN THE AREA. NO ACTIVITIES ARE PERMITTED TO OCCUR BEYOND THE CONSTRUCTION BARRIER.
4. CONSTRUCTION ENTRANCES SHALL BE INSTALLED AT THE BEGINNING OF CONSTRUCTION AND MAINTAINED FOR THE DURATION OF THE PROJECT. ADDITIONAL MEASURES INCLUDING, BUT NOT LIMITED TO, STREET SWEEPING, AND VACUUMING, MAY BE REQUIRED TO INSURE THAT ALL PAVED AREAS ARE KEPT CLEAN FOR THE DURATION OF THE PROJECT.
5. RUN-ON AND RUN-OFF CONTROLS SHALL BE IN PLACE AND FUNCTIONING PRIOR TO BEGINNING SUBSTANTIAL CONSTRUCTION ACTIVITIES. RUN-ON AND RUN-OFF CONTROL MEASURES INCLUDE: CHECK DAMS, SURFACE ROUGHENING, BANK STABILIZATION, AND SEDIMENT FENCE.

**EROSION AND SEDIMENT CONSTRUCTION NOTES:**

1. SEED USED FOR TEMPORARY OR PERMANENT SEEDING SHALL BE COMPOSED OF THE FOLLOWING MIXTURE, UNLESS OTHERWISE AUTHORIZED:  
SEED MIX (MIN. 10LB/AC.)  
1. BLUE BUNCH WHEATGRASS  
2. REGREEN  
3. IDAHO FESCUE  
4. CANBY BLUEGRASS  
5. PRAIRIE JUNE GRASS
2. SLOPE TO RECEIVE TEMPORARY OR PERMANENT SEEDING SHALL HAVE THE SURFACE ROUGHENED BY MEANS OF TRACK-WALKING OR THE USE OF OTHER APPROVED IMPLEMENTS. SURFACE ROUGHENING IMPROVES SEED BEDDING AND REDUCES RUN-OFF VELOCITY.
3. LONG TERM SLOPE STABILIZATION MEASURES SHALL INCLUDE THE ESTABLISHMENT OF PERMANENT VEGETATIVE COVER VIA SEEDING WITH APPROVED MIX AND APPLICATION RATE.
4. TEMPORARY SLOPE STABILIZATION MEASURES SHALL INCLUDE: COVERING EXPOSED SOIL WITH PLASTIC SHEETING, STRAW MULCHING, WOOD CHIPS, OR OTHER APPROVED MEASURES.
5. STOCKPILED SOIL OR STRIPPINGS SHALL BE PLACED IN A STABLE LOCATION AND CONFIGURATION. DURING "WET WEATHER" PERIODS, STOCKPILES SHALL BE COVERED WITH PLASTIC SHEETING OR STRAW MULCH. SEDIMENT FENCE IS REQUIRED AROUND THE PERIMETER OF THE STOCKPILE.
6. EXPOSED CUT OR FILL AREAS SHALL BE STABILIZED WITHIN 14 DAYS IF COMPLETION THROUGH THE USE OF TEMPORARY SEEDING AND MULCHING, EROSION CONTROL BLANKETS OR MATS, MID-SLOPE SEDIMENT FENCES OR WATTLES, OR OTHER APPROPRIATE MEASURES. SLOPES EXCEEDING 25% MAY REQUIRE ADDITIONAL EROSION CONTROL MEASURES.
7. AREAS SUBJECT TO WIND EROSION SHALL USE APPROPRIATE DUST CONTROL MEASURES INCLUDING THE APPLICATION OF A FINE SPRAY OF WATER, PLASTIC SHEETING, STRAW MULCHING, OR OTHER APPROVED MEASURES.
8. CONSTRUCTION ENTRANCES SHALL BE INSTALLED AT THE BEGINNING OF CONSTRUCTION AND MAINTAINED FOR THE DURATION OF THE PROJECT. ADDITIONAL MEASURES INCLUDING, BUT NOT LIMITED TO, TIRE WASHES, STREET SWEEPING, AND VACUUMING MAY BE REQUIRED TO INSURE THAT ALL PAVED AREAS ARE KEPT CLEAN FOR THE DURATION OF THE PROJECT.
9. ACTIVE INLETS TO STORM WATER SYSTEMS SHALL BE PROTECTED THROUGH THE USE OF THE APPROVED INLET PROTECTION MEASURES. ALL INLET PROTECTION MEASURES ARE TO BE REGULARLY INSPECTED AND MAINTAINED AS NEEDED.
10. SATURATED MATERIALS THAT ARE HAULED OFF-SITE MUST BE TRANSPORTED IN WATER-TIGHT TRUCKS TO ELIMINATE SPILLAGE OF SEDIMENT AND SEDIMENT-LADEN WATER.
11. AN AREA SHALL BE PROVIDED FOR THE WASHING OUT OF CONCRETE TRUCKS IN A LOCATION THAT DOES NOT PROVIDE RUN-OFF THAT CAN ENTER THE STORM WATER SYSTEM. IF THE CONCRETE WASH-OUT AREA CAN NOT BE CONSTRUCTED GREATER THAN 50' FROM ANY DISCHARGE POINT, SECONDARY MEASURES SUCH AS BERMS OR TEMPORARY SETTLING PITS MAY BE REQUIRED. THE WASH-OUT SHALL BE LOCATED WITHIN SIX FEET OF TRUCK ACCESS AND BE CLEANED WHEN IT REACHES 50% OF THE CAPACITY.
12. SWEEPINGS FROM EXPOSED AGGREGATE CONCRETE SHALL NOT BE TRANSFERRED TO THE STORM WATER SYSTEM. SWEEPINGS SHALL BE PICKED UP AND DISPOSED IN THE TRASH.
13. AVOID PAVING IN WET WEATHER WHEN PAVING CHEMICALS CAN RUN-OFF INTO THE STORM WATER SYSTEM.
14. USE BMPs SUCH AS CHECK-DAMS, BERMS, AND INLET PROTECTION TO PREVENT RUN-OFF FROM REACHING DISCHARGE POINTS.
15. COVER CATCH BASINS, MANHOLES, AND OTHER DISCHARGE POINTS WHEN APPLYING SEAL COAT, TACK COAT, ETC. TO PREVENT INTRODUCING THESE MATERIALS TO THE STORM WATER SYSTEM.

**CONSTRUCTION PHASING**

- PHASE 1  
1. PLACE PERIMETER STRAW WATTLES AND SEDIMENT FENCE
- PHASE 2  
1. CONSTRUCT ENTRY ROADWAY  
2. CONSTRUCT SITE IMPROVEMENTS  
3. HYDROSEED AREAS ALL DISTURBED
- PHASE 3  
1. CLEAN OUT AND RESTORE SITE

**EROSION AND SEDIMENT CONTROL BMP IMPLEMENTATION:**

1. ALL BASE ESC MEASURES (INLET PROTECTION, PERIMETER SEDIMENT CONTROL, GRAVEL CONSTRUCTION ENTRANCES, ETC.) MUST BE IN PLACE, FUNCTIONAL, AND APPROVED IN AN INITIAL INSPECTION, PRIOR TO COMMENCEMENT OF CONSTRUCTION ACTIVITIES.
  2. ALL "SEDIMENT BARRIERS (TO BE INSTALLED AFTER GRADING)" SHALL BE INSTALLED IMMEDIATELY FOLLOWING ESTABLISHMENT OF FINISHED GRADE AS SHOWN ON THESE PLANS.
  3. LONG TERM SLOPE STABILIZATION MEASURES "INCLUDE MATTING" SHALL BE IN PLACE OVER ALL EXPOSED SOIL BY OCTOBER 1.
  4. THE STORM WATER FACILITY SHALL BE CONSTRUCTED AND LANDSCAPED PRIOR TO THE STORM WATER SYSTEM FUNCTIONING AND SITE PAVING.
  5. INLET PROTECTION SHALL BE IN-PLACE IMMEDIATELY FOLLOWING PAVING ACTIVITIES.
  6. DUST ABATEMENT WATERING CREWS WILL SPRAY WATER ON SOILS IN A MANNER THAT DOES NOT RESULT IN POOLING OR CHANNELIZING OF WATER.
- THESE EROSION AND SEDIMENT CONTROL PLANS ASSUME "DRY WEATHER" CONSTRUCTION. "WET WEATHER" CONSTRUCTION MEASURES NEED TO BE APPLIED BETWEEN OCTOBER 1ST AND MAY 31ST.

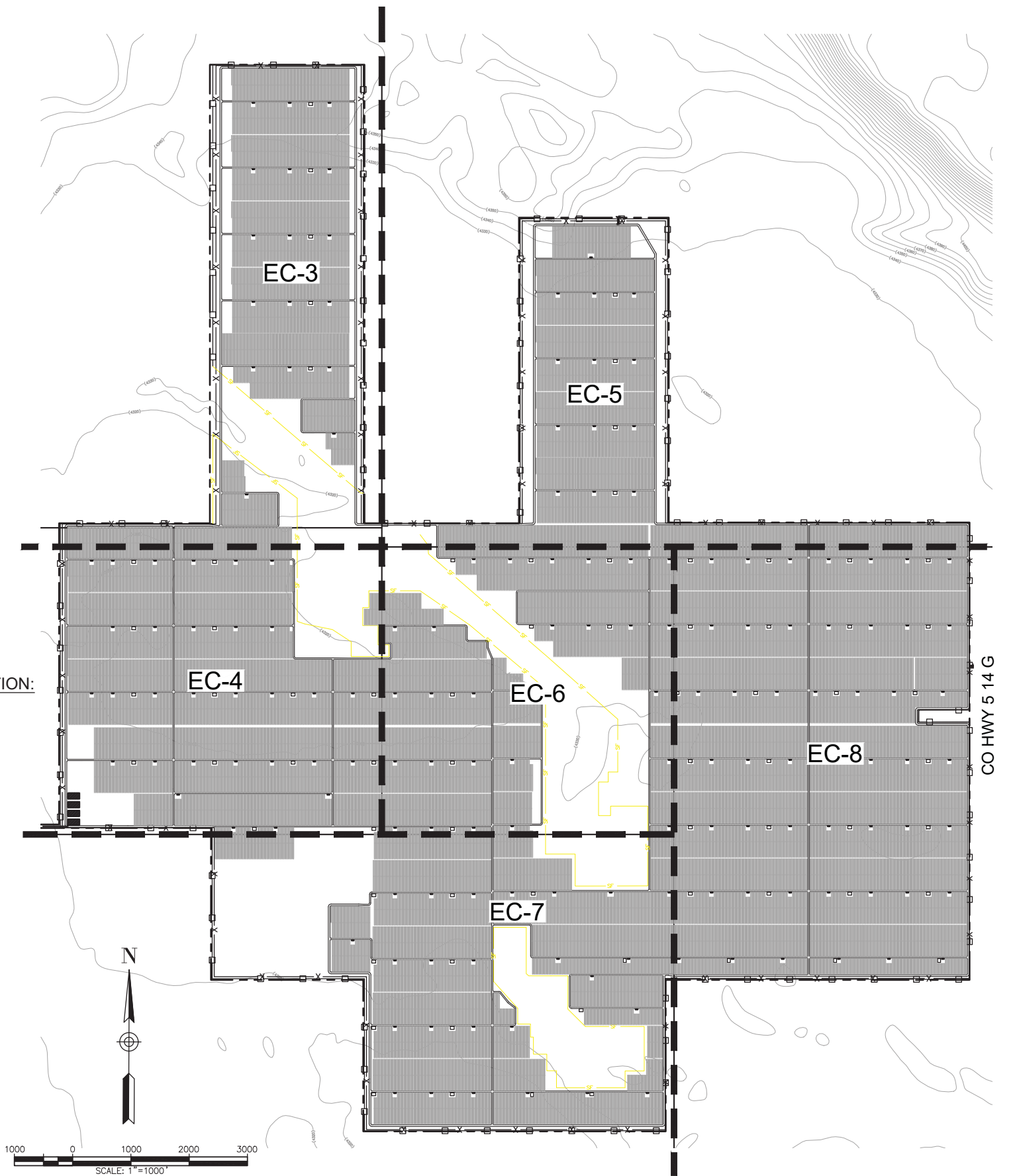

**PRELIMINARY  
NOT FOR CONSTRUCTION**

REVISIONS:

**EROSION AND SEDIMENT CONTROL PLAN**

**Michael Baker INTERNATIONAL**  
9755 Clairemont Mesa Blvd., San Diego, CA 92124  
Phone: (858) 614-5000 · MBAKERINTL.COM







DESIGNED BY: JM	DRAWING NO.: 168058
DRAWN BY: JM	SCALE: AS NOTED
CHECKED BY: ST	
PREPARED FOR:	SWINERTON BUILDERS 16798 WEST BERNARDO DRIVE SAN DIEGO, CA 92127 PHONE: 858-229-5774

**OBSIDIAN SOLAR CENTER**  
**FORT ROCK OREGON**  
TAX LOTS 2702, 2708, 4600, 5800 LAKE COUNTY TAX MAP 26 16

REGISTERED PROFESSIONAL ENGINEER  
84501PE  
OREGON  
JUNE 30, 2020  
SCOTT M. TAYLOR

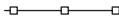
JOB NUMBER
SHEET
EC-2

**LEGEND**

-  PROPOSED COMPACTED NATIVE SOIL ACCESS ROAD
-  CONSTRUCTION ENTRANCE
-  STRAW WATTLES TO BE INSTALLED
-  SEDIMENT FENCE TO BE INSTALLED
-  DRAINAGE WATTLES TO BE INSTALLED
-  CONCRETE WASHOUT
-  TIRE WASH

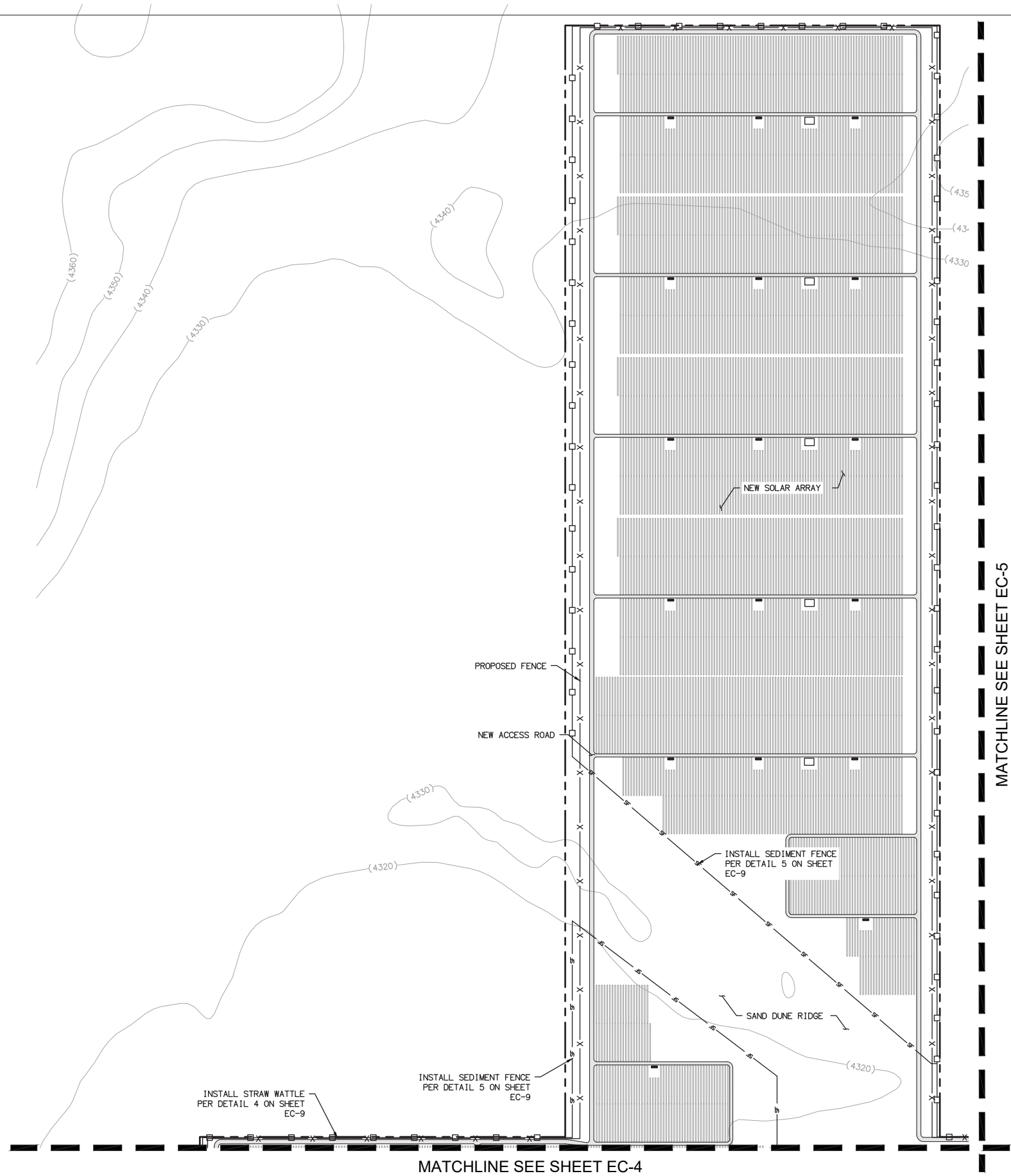

MATCHLINE SEE SHEET EC-5

MATCHLINE SEE SHEET EC-4

**PRELIMINARY  
NOT FOR CONSTRUCTION**

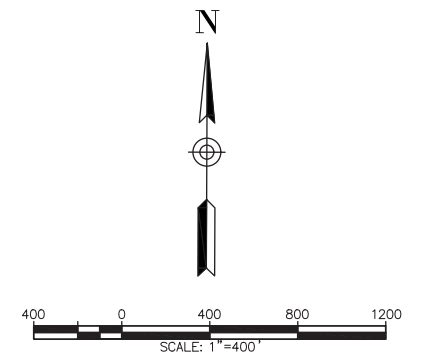

REVISIONS:

**EROSION AND SEDIMENT CONTROL PLAN**

**Michael Baker INTERNATIONAL**  
 9755 Clairemont Mesa Blvd., San Diego, CA 92124  
 Phone: (858) 614-5000 · MBAKERINTL.COM





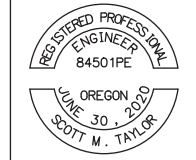

DESIGNED BY: JM      DRAWING NO.: 168058  
 DRAWN BY: JM      SCALE: AS NOTED  
 CHECKED BY: ST  
 PREPARED FOR: SWINERTON BUILDERS  
 16708 WEST BERNARDO DRIVE  
 SAN DIEGO, CA 92127  
 PHONE: 858-229-5774

**OBSIDIAN SOLAR CENTER**  
**FORT ROCK OREGON**  
 TAX LOTS 2702, 2708, 4600, 5800 LAKE COUNTY TAX MAP 26 16

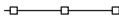

JOB NUMBER  
 SHEET  
**EC-3**

**LEGEND**

-  PROPOSED COMPACTED NATIVE SOIL ACCESS ROAD
-  CONSTRUCTION ENTRANCE
-  STRAW WATTLES TO BE INSTALLED
-  SEDIMENT FENCE TO BE INSTALLED
-  DRAINAGE WATTLES TO BE INSTALLED
-  CONCRETE WASHOUT
-  TIRE WASH

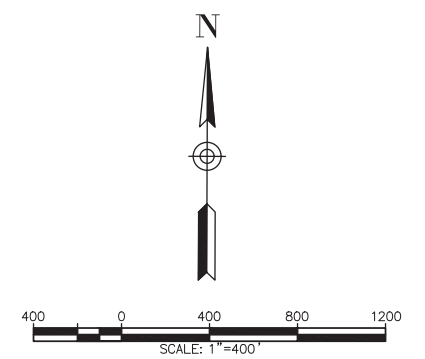
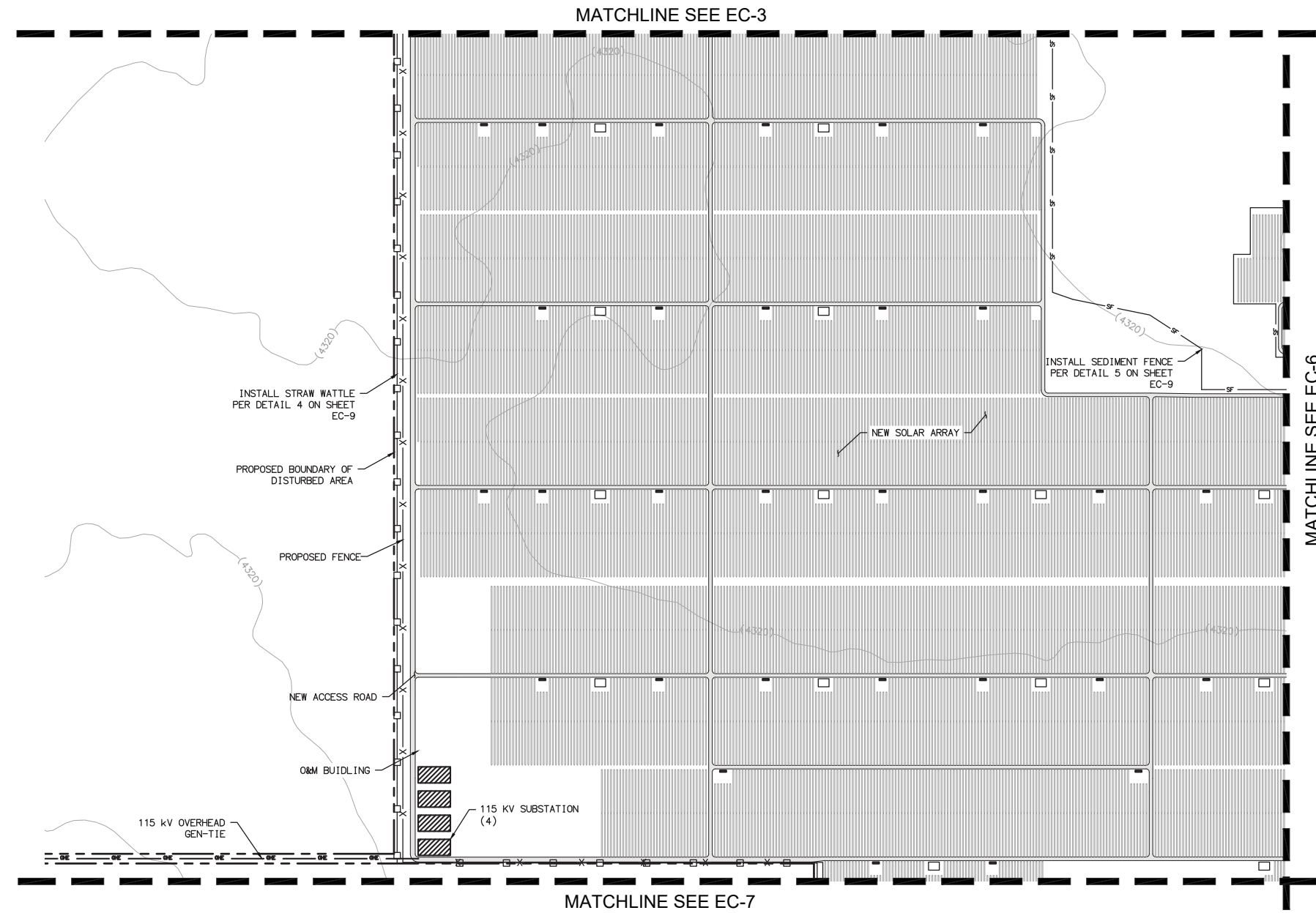

**PRELIMINARY  
NOT FOR CONSTRUCTION**

REVISIONS:

**EROSION AND SEDIMENT CONTROL PLAN**

**Michael Baker INTERNATIONAL**  
 9755 Clairemont Mesa Blvd., San Diego, CA 92124  
 Phone: (858) 614-5000 · MBAKERINTL.COM







DESIGNED BY: JM	DRAWING NO.: 168058
DRAWN BY: JM	SCALE: AS NOTED
CHECKED BY: ST	
PERPARED FOR:	SWINERTON BUILDERS 16798 WEST BERNARDO DRIVE SAN DIEGO, CA 92127 PHONE: 858-229-5774

**OBSIDIAN SOLAR CENTER**  
**FORT ROCK OREGON**  
 TAX LOTS 2702, 2708, 4600, 5800 LAKE COUNTY TAX MAP 26 16

JOB NUMBER
SHEET EC-4

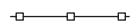

**LEGEND**

-  PROPOSED COMPACTED NATIVE SOIL ACCESS ROAD
-  CONSTRUCTION ENTRANCE
-  STRAW WATTLES TO BE INSTALLED
-  SF SEDIMENT FENCE TO BE INSTALLED
-  DW DRAINAGE WATTLES TO BE INSTALLED
-  CONCRETE WASHOUT
-  TIRE WASH

MATCHLINE SEE EC-3

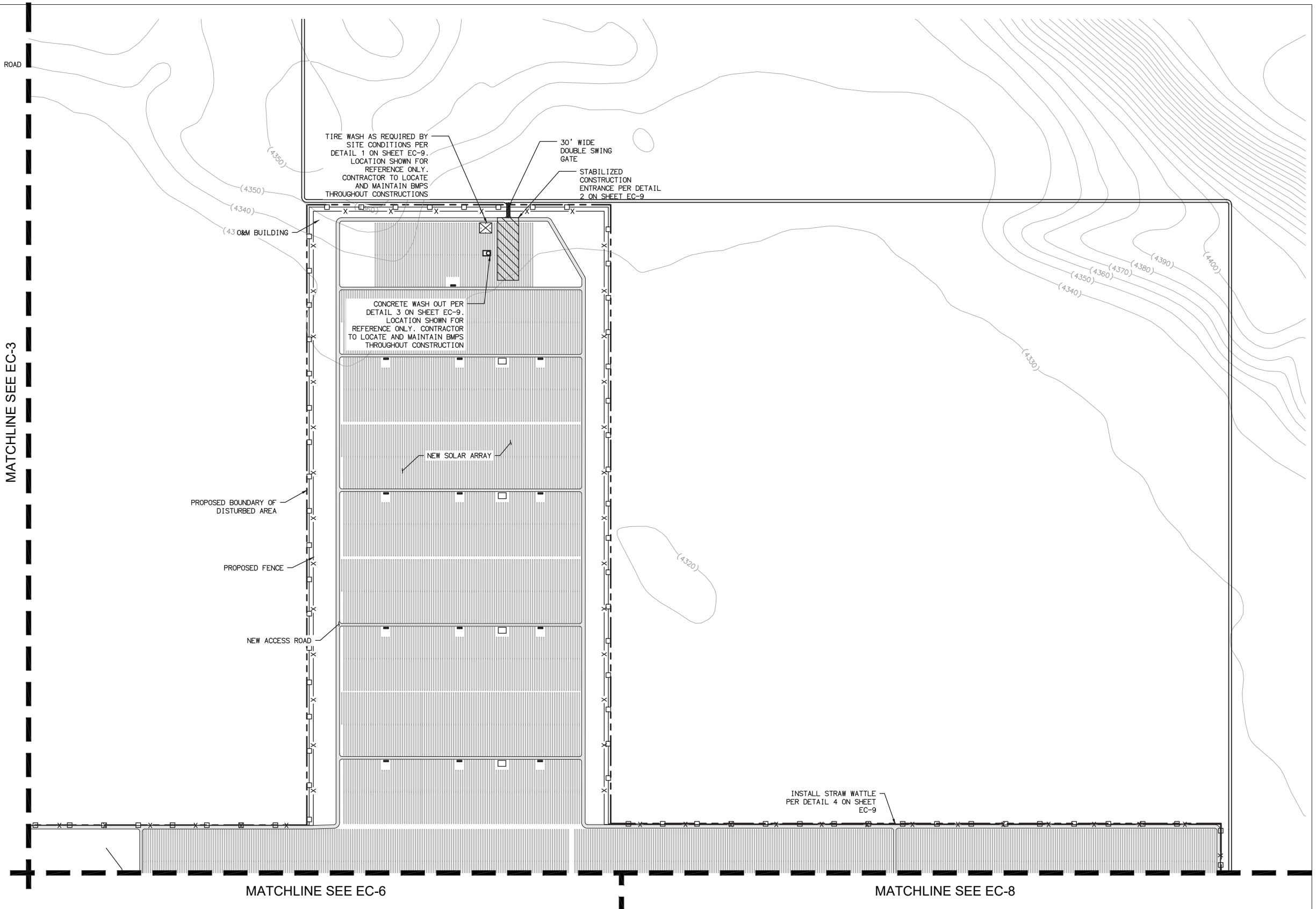

MATCHLINE SEE EC-6

MATCHLINE SEE EC-8

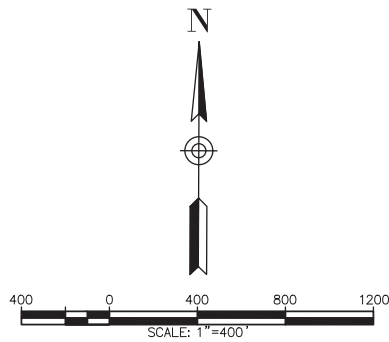

**PRELIMINARY  
NOT FOR CONSTRUCTION**

REVISIONS:

**EROSION AND SEDIMENT  
CONTROL PLAN**

**Michael Baker  
INTERNATIONAL**  
9755 Clairemont Mesa Blvd., San Diego, CA 92124  
Phone: (858) 614-5000 · MBAKERINTL.COM

DESIGNED BY: JM	DRAWING NO.: 168058
DRAWN BY: JM	SCALE: AS NOTED
CHECKED BY: ST	
PREPARED FOR:	SWINERTON BUILDERS 16798 WEST BERNARDO DRIVE SAN DIEGO, CA 92127 PHONE: 858-229-5774

**OBSIDIAN SOLAR CENTER**





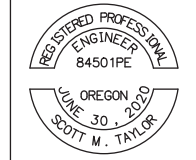

**FORT ROCK OREGON**

TAX LOTS 2702, 2708, 4600, 5800 LAKE COUNTY TAX MAP 26 16

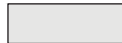

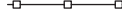
JOB NUMBER
SHEET EC-5

**LEGEND**

-  PROPOSED COMPACTED NATIVE SOIL ACCESS ROAD
-  CONSTRUCTION ENTRANCE
-  STRAW WATTLES TO BE INSTALLED
-  SF SEDIMENT FENCE TO BE INSTALLED
-  DW DRAINAGE WATTLES TO BE INSTALLED
-  CONCRETE WASHOUT
-  TIRE WASH

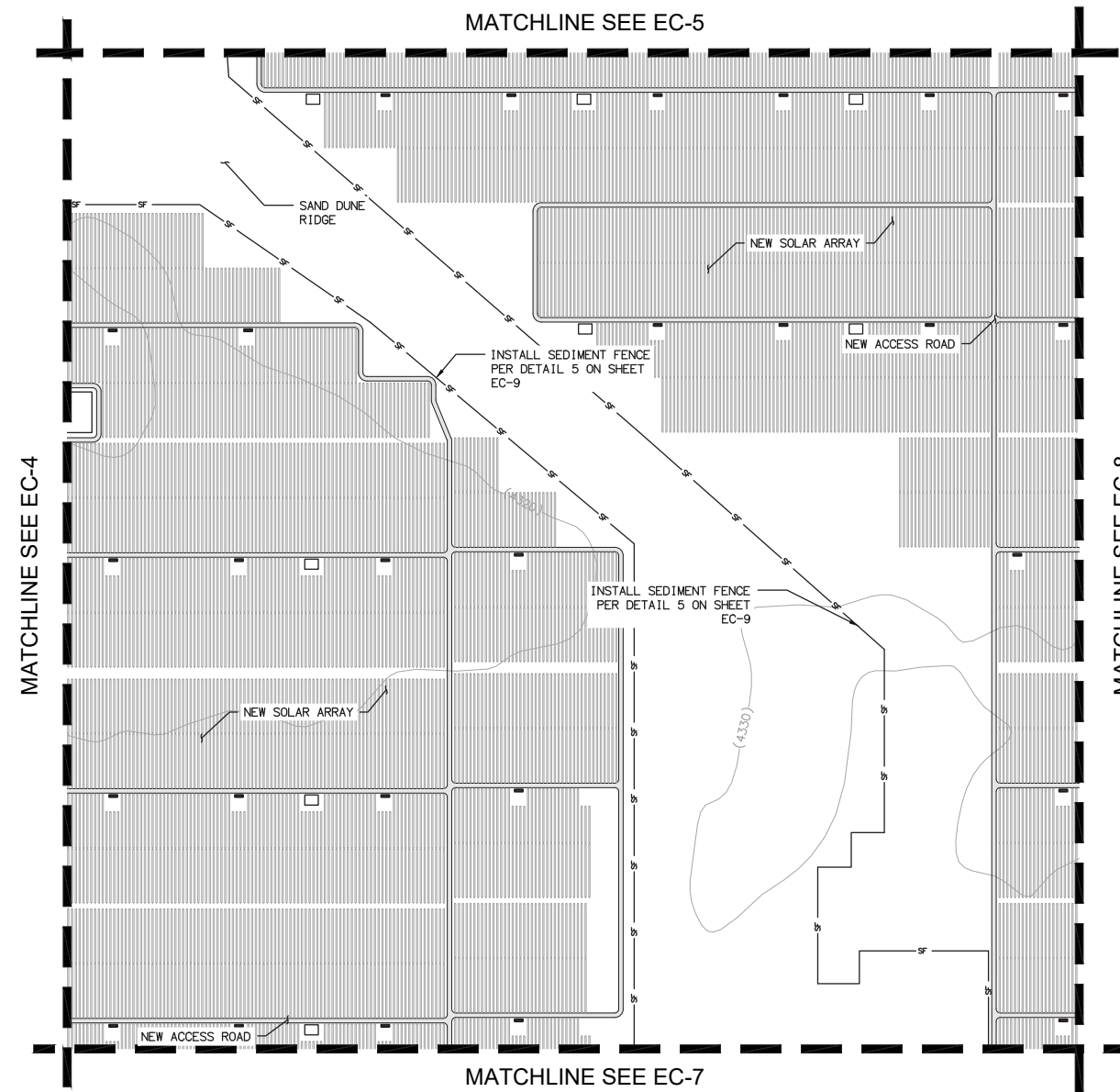

PRELIMINARY  
NOT FOR CONSTRUCTION

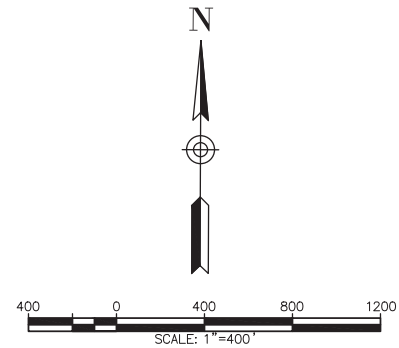

REVISIONS:

**EROSION AND SEDIMENT CONTROL PLAN**

**Michael Baker INTERNATIONAL**  
9755 Clairemont Mesa Blvd., San Diego, CA 92124  
Phone: (858) 614-5000 · MBAKERINTL.COM





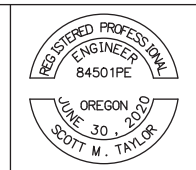

DESIGNED BY: JM	DRAWING NO.: 168058
DRAWN BY: JM	SCALE: AS NOTED
CHECKED BY: ST	
PREPARED FOR:	SWINERTON BUILDERS 16798 WEST BERNARDO DRIVE SAN DIEGO, CA 92127 PHONE: 858-229-5774

**OBSIDIAN SOLAR CENTER**  
**FORT ROCK OREGON**  
TAX LOTS 2702, 2708, 4600, 5800 LAKE COUNTY TAX MAP 26 16

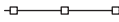

JOB NUMBER
SHEET
EC-6

**LEGEND**

-  PROPOSED COMPACTED NATIVE SOIL ACCESS ROAD
-  CONSTRUCTION ENTRANCE
-  STRAW WATTLES TO BE INSTALLED
-  SEDIMENT FENCE TO BE INSTALLED
-  DRAINAGE WATTLES TO BE INSTALLED
-  CONCRETE WASHOUT
-  TIRE WASH

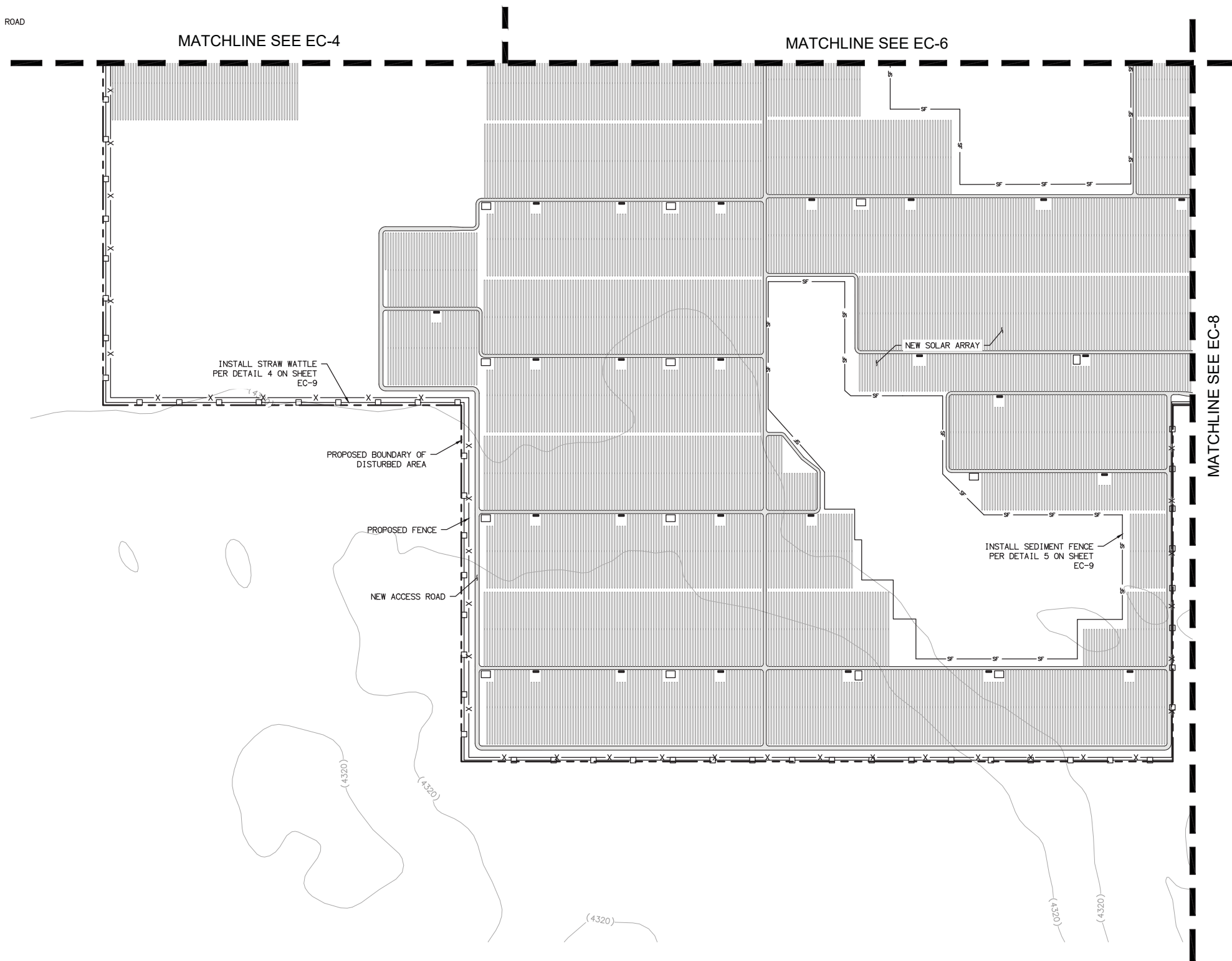

**PRELIMINARY  
NOT FOR CONSTRUCTION**

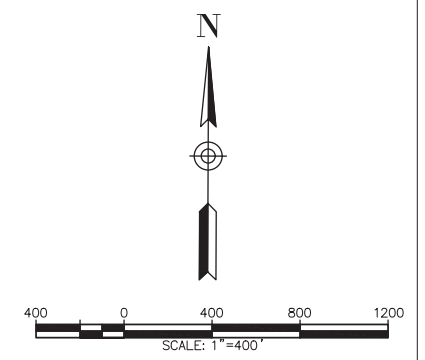

REVISIONS:

**EROSION AND SEDIMENT CONTROL PLAN**

**Michael Baker INTERNATIONAL**  
 9755 Clairemont Mesa Blvd., San Diego, CA 92124  
 Phone: (858) 614-5000 · MBAKERINTL.COM





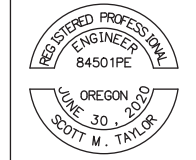

DESIGNED BY: JM      DRAWING NO.: 168058  
 DRAWN BY: JM      SCALE: AS NOTED  
 CHECKED BY: ST  
 PREPARED FOR: SWINERTON BUILDERS  
 16798 WEST BERNARDO DRIVE  
 SAN DIEGO, CA 92127  
 PHONE: 858-229-5774

**OBSIDIAN SOLAR CENTER**  
**FORT ROCK OREGON**  
 TAX LOTS 2702, 2708, 4600, 5800 LAKE COUNTY TAX MAP 26 16

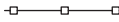

JOB NUMBER  
  
 SHEET  
**EC-7**

**LEGEND**

-  PROPOSED COMPACTED NATIVE SOIL ACCESS ROAD
-  CONSTRUCTION ENTRANCE
-  STRAW WATTLES TO BE INSTALLED
-  SF SEDIMENT FENCE TO BE INSTALLED
-  DW DRAINAGE WATTLES TO BE INSTALLED
-  CONCRETE WASHOUT
-  TIRE WASH

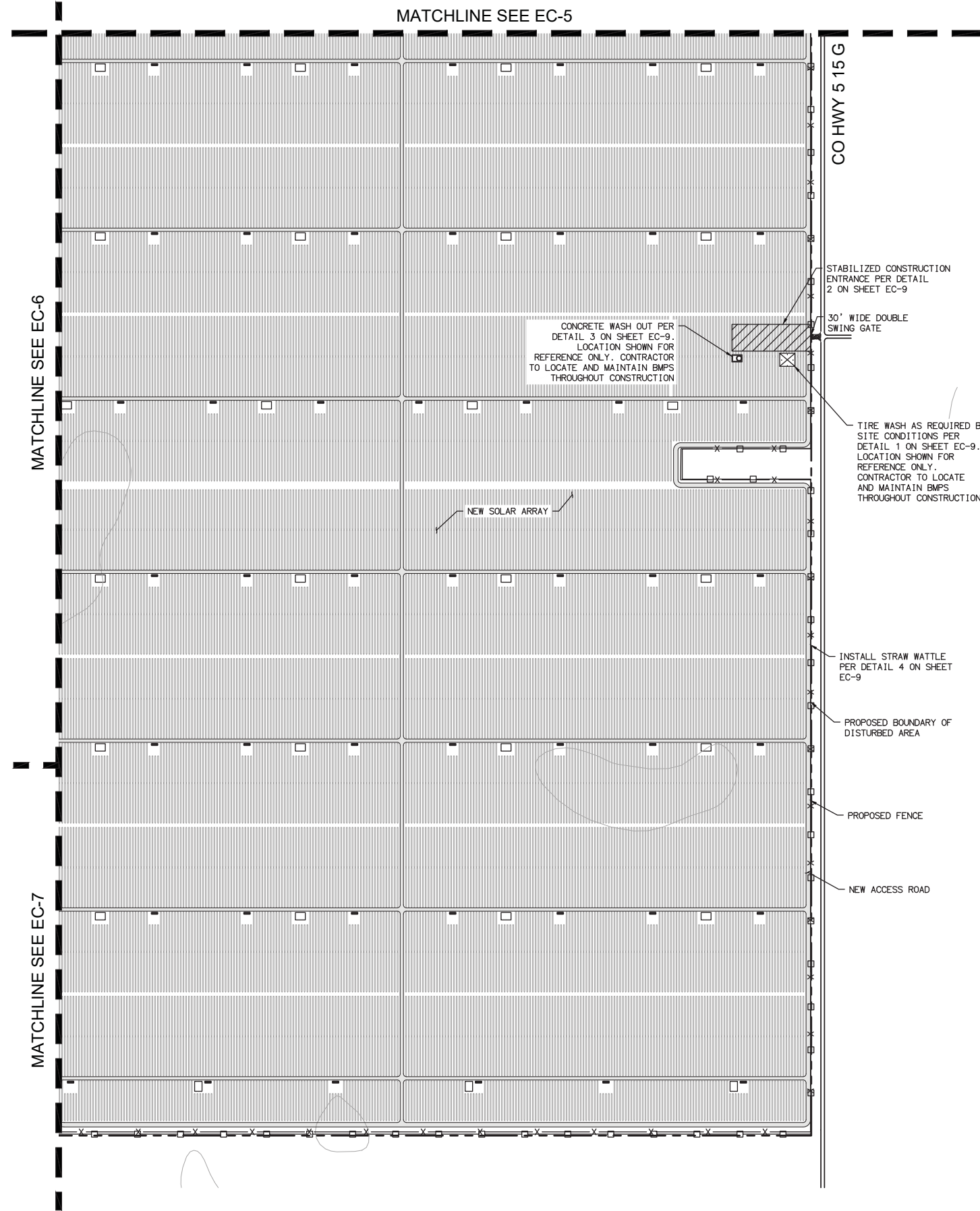

**PRELIMINARY  
NOT FOR CONSTRUCTION**

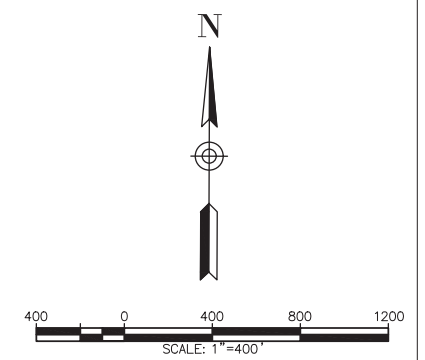

REVISIONS:

**EROSION AND SEDIMENT CONTROL PLAN**

**Michael Baker INTERNATIONAL**  
 9755 Clairemont Mesa Blvd., San Diego, CA 92124  
 Phone: (858) 614-5000 · MBAKERINTL.COM

DESIGNED BY: JM	DRAWING NO.: 168058
DRAWN BY: JM	SCALE: AS NOTED
CHECKED BY: ST	
PREPARED FOR:	SWINERTON BUILDERS 16708 WEST BERNARDO DRIVE SAN DIEGO, CA 92127 PHONE: 858-229-5774

**OBSIDIAN SOLAR CENTER**  
**FORT ROCK OREGON**  
 TAX LOTS 2702, 2708, 4600, 5800 LAKE COUNTY TAX MAP 26 16

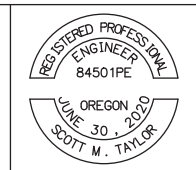

JOB NUMBER
SHEET EC-8

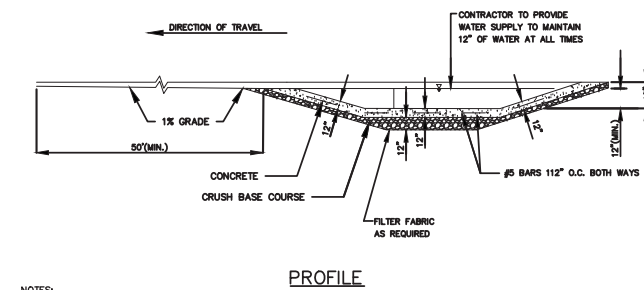
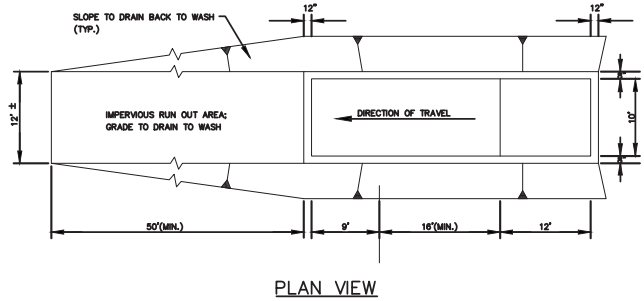

- NOTES:**
- CONTRACTOR TO REMOVE ACCUMULATED SEDIMENT AS NEEDED TO PREVENT TRACKING FROM TIRE WASH. SEDIMENT LADEN WATER MAY BE PIPED TO AN APPROVED SEDIMENT TRAP.
  - USE GEOTEXTILE FABRIC WITH AGGREGATE FOR A TEMPORARY TIRE WASH.
- FOR FURTHER INFORMATION ON DESIGN CRITERIA SEE CHAPTER 4 OF CLEAN WATER SERVICES EROSION PREVENTION AND SEDIMENT CONTROL PLANNING AND DESIGN MANUAL.

**1 TIRE WASH**  
N.T.S

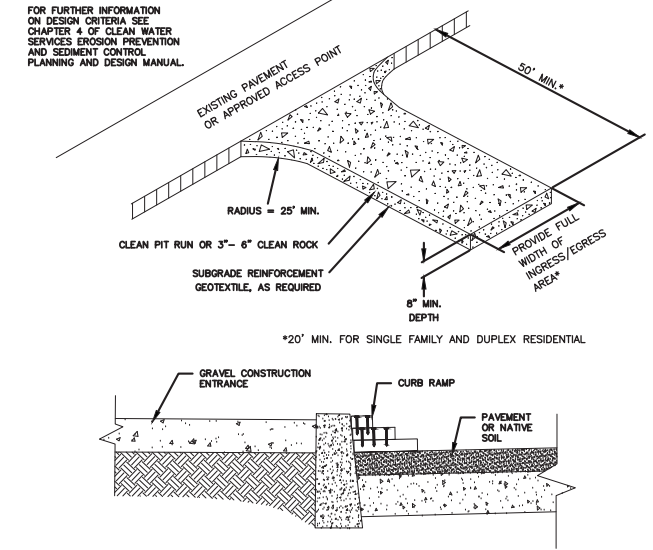

- NOTES:**
- THE ENTRANCE SHALL BE MAINTAINED IN A CONDITION THAT WILL PREVENT TRACKING OR FLOWING OF SEDIMENT ONTO PUBLIC RIGHT-OF-WAYS. THIS MAY REQUIRE TOP DRESSING, REPAIR AND/OR CLEAN OUT OF ANY MEASURES USED TO TRAP SEDIMENT.
  - WHEN NECESSARY, WHEELS SHALL BE CLEANED PRIOR TO ENTRANCE ONTO PUBLIC RIGHT-OF-WAY.
  - WHEN WASHING IS REQUIRED, IT SHALL BE DONE ON AN AREA STABILIZED WITH CRUSHED STONE THAT DRAINS INTO AN APPROVED SEDIMENT TRAP OR SEDIMENT BASIN.
  - WHERE RUNOFF CONTAINING SEDIMENT LADEN WATER IS LEAVING THE SITE VIA THE CONSTRUCTION ENTRANCE, OTHER MEASURES SHALL BE IMPLEMENTED TO DIVERT RUNOFF THROUGH AN APPROVED FILTERING SYSTEM.

**2 CONSTRUCTION ENTRANCE**  
N.T.S

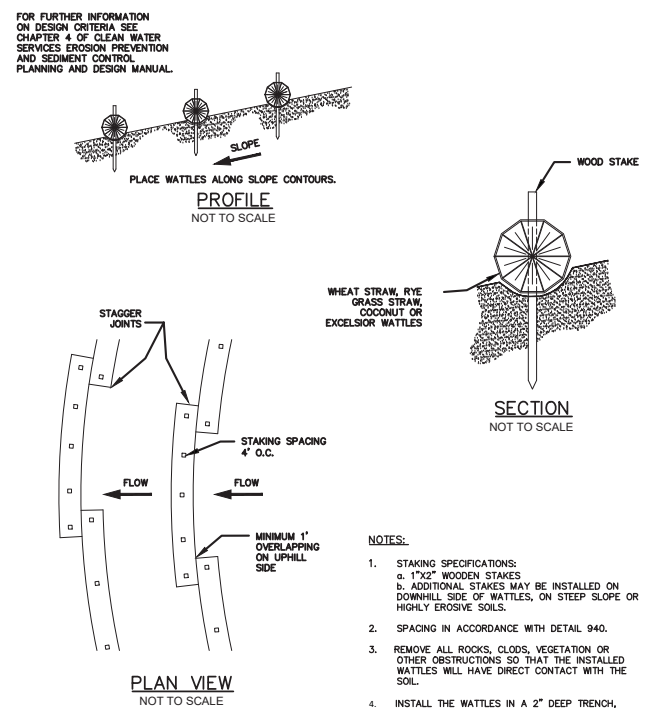

**4 STRAW WATTLE**  
N.T.S

DETAIL 940

BARRIER SPACING FOR GENERAL APPLICATION		
INSTALL PARALLEL ALONG CONTOURS AS FOLLOWS		
% SLOPE	SLOPE	MAXIMUM SPACING ON SLOPE
10% OR FLATTER	10:1 OR FLATTER	300 FT
>10% OR <15%	>10:1 OR <7.5:1	150 FT
>15% OR <20%	>7.5:1 OR <5:1	100 FT
>20% OR <30%	>5:1 OR <3.5:1	50 FT
>30% OR <50%	>3.5:1 OR <2:1	25 FT

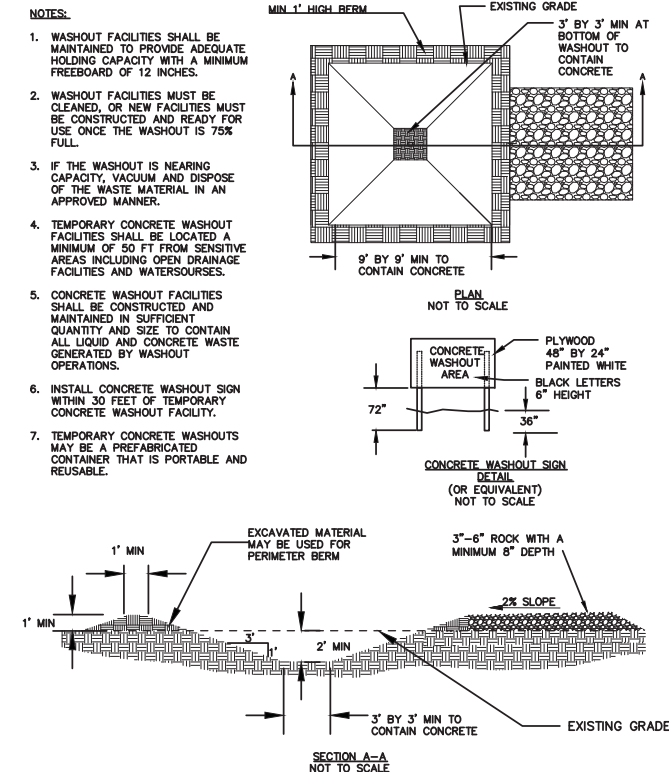

**3 CONCRETE WASH OUT**  
N.T.S

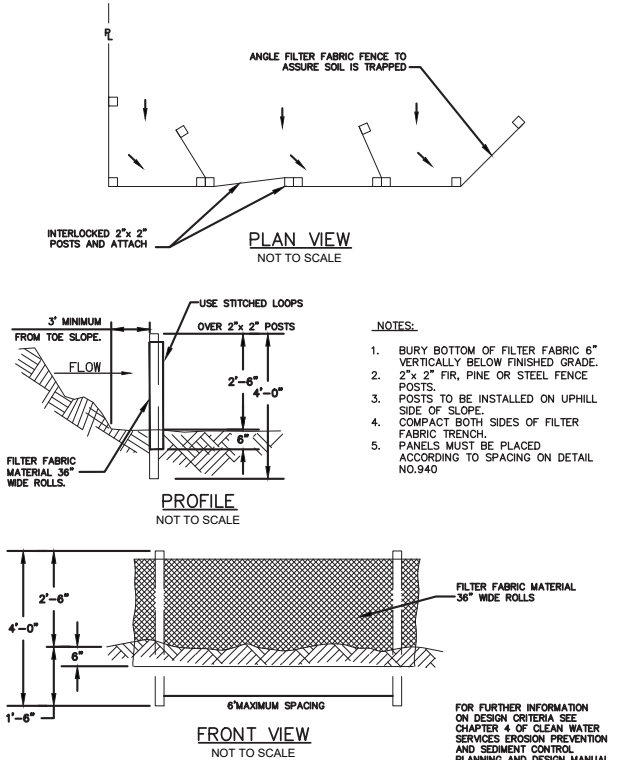

**5 SEDIMENT FENCE**  
N.T.S

PRELIMINARY  
NOT FOR CONSTRUCTION

REVISIONS:

**EROSION AND SEDIMENT CONTROL STANDARD DETAILS**

**Michael Baker INTERNATIONAL**  
9755 Clairmont Mesa Blvd., San Diego, CA 92124  
Phone: (858) 614-5000 • MBAKERINTL.COM





DESIGNED BY: JM DRAWING NO.: 168058  
DRAWN BY: JM SCALE: AS NOTED  
CHECKED BY: ST  
PREPARED FOR: SWINERTON BUILDERS  
16798 WEST BERNARDO DRIVE  
SAN DIEGO, CA 92127  
PHONE: 858-229-5774

**OBSIDIAN SOLAR CENTER**  
**FORT ROCK OREGON**  
TAX LOTS 2702, 2708, 4600, 5800 LAKE COUNTY TAX MAP 26 16

REGISTERED PROFESSIONAL ENGINEER  
84501PE  
OREGON  
JUNE 30, 2020  
SCOTT M. TAYLOR

JOB NUMBER  
SHEET  
EC-9

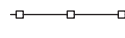
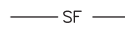
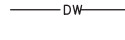
**LEGEND**

-  PROPOSED COMPACTED NATIVE SOIL ACCESS ROAD
-  CONSTRUCTION ENTRANCE
-  STRAW WATTLES TO BE INSTALLED
-  SEDIMENT FENCE TO BE INSTALLED
-  DRAINAGE WATTLES TO BE INSTALLED
-  CONCRETE WASHOUT
-  TIRE WASH

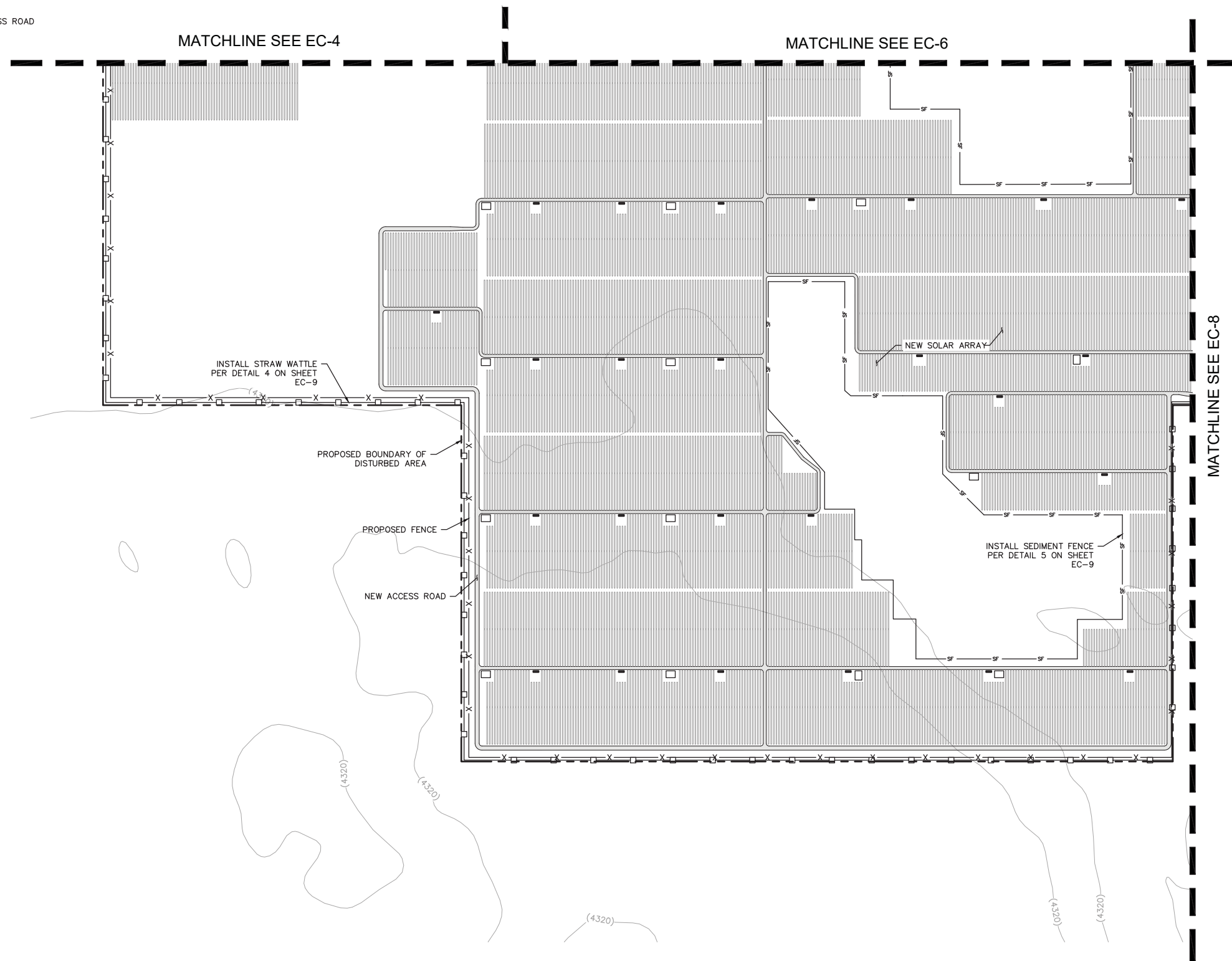

**PRELIMINARY  
NOT FOR CONSTRUCTION**

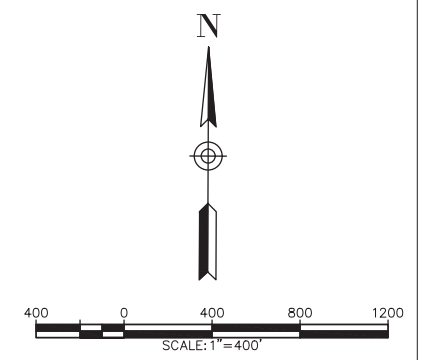

REVISIONS:

**EROSION AND SEDIMENT CONTROL PLAN**

**Michael Baker INTERNATIONAL**  
 9755 Clairemont Mesa Blvd., San Diego, CA 92124  
 Phone: (858) 614-5000 · MBAKERINTL.COM







DESIGNED BY: JM      DRAWING NO.: 168058  
 DRAWN BY: JM      SCALE: AS NOTED  
 CHECKED BY: ST  
 PREPARED FOR: SWINERTON BUILDERS  
 16798 WEST BERNARDO DRIVE  
 SAN DIEGO, CA 92127  
 PHONE: 858-229-5774

**OBSIDIAN SOLAR CENTER**  
**FORT ROCK OREGON**  
 TAX LOTS 2702, 2708, 4600, 5800 LAKE COUNTY TAX MAP 26 16

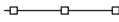

JOB NUMBER  
 SHEET  
**EC-7**

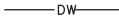
**LEGEND**

-  PROPOSED COMPACTED NATIVE SOIL ACCESS ROAD
-  CONSTRUCTION ENTRANCE
-  STRAW WATTLES TO BE INSTALLED
-  SEDIMENT FENCE TO BE INSTALLED
-  DRAINAGE WATTLES TO BE INSTALLED
-  CONCRETE WASHOUT
-  TIRE WASH

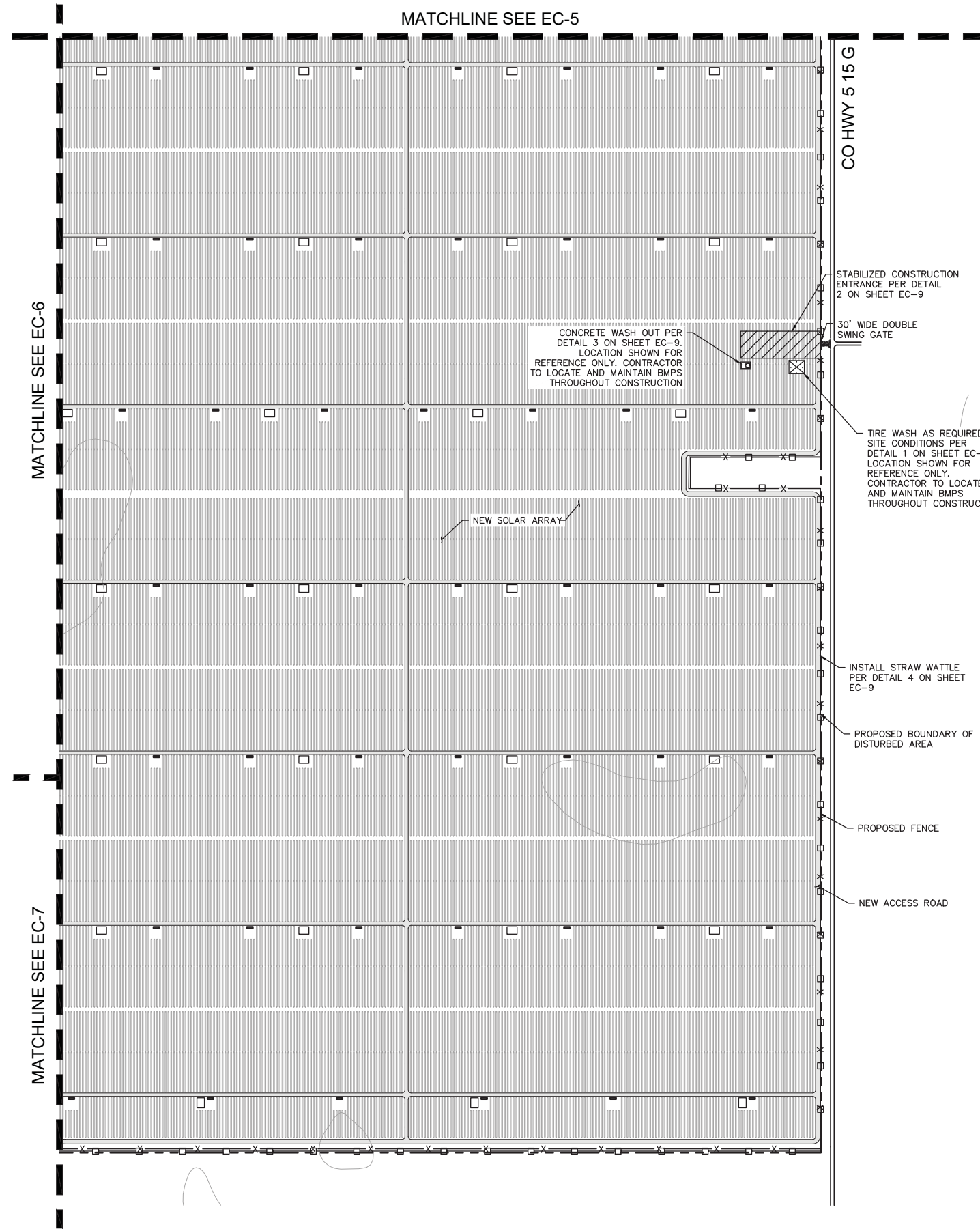

**PRELIMINARY  
NOT FOR CONSTRUCTION**

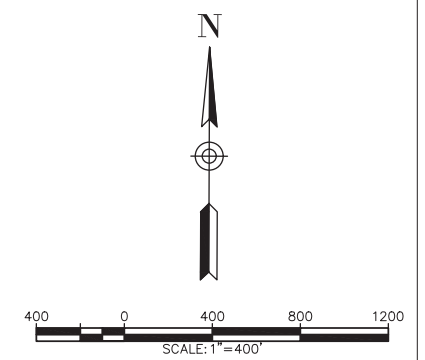

REVISIONS:

**EROSION AND SEDIMENT CONTROL PLAN**

**Michael Baker INTERNATIONAL**  
 9755 Clairemont Mesa Blvd., San Diego, CA 92124  
 Phone: (858) 614-5000 · MBAKERINTL.COM

DESIGNED BY: JM	DRAWING NO.: 168058
DRAWN BY: JM	SCALE: AS NOTED
CHECKED BY: ST	
PREPARED FOR:	SWINERTON BUILDERS 16738 WEST BERNARDO DRIVE SAN DIEGO, CA 92127 PHONE: 858-229-5774

**OBSIDIAN SOLAR CENTER**  
**FORT ROCK OREGON**  
 TAX LOTS 2702, 2708, 4600, 5800 LAKE COUNTY TAX MAP 26 16

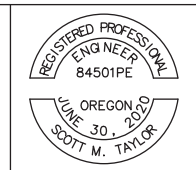

JOB NUMBER
SHEET
EC-8





# **Appendix I-2**

# **Draft Spill Management Plan**



## 1. Plan Information & Certification

This document constitutes a provisional Spill Prevention, Control, and Countermeasure (SPCC) Plan for the Obsidian Solar Center facility. A final SPCC plan will be completed and signed by the owner or operator of the facility. This plan addresses the requirements of 40 CFR part 112.

Maintain a complete copy of the Plan at the facility if the facility is normally attended at least four hours per day, or for a facility attended fewer than four hours per day, at the nearest field office. When making operational changes at a facility that are necessary to comply with the rule requirements, the owner/operator should follow state and local requirements (such as for permitting, design and construction) and obtain professional assistance, as appropriate.

### Facility Description

Facility Name	Obsidian Solar Center
Facility Address	TBD
City	Fort Rock
State	Oregon
ZIP	97735
County	Lake County
Telephone Number	(503) 245-5800
Owner or Operator Name	TBD
Owner or Operator Address	
City	
State	
ZIP	
County	
Telephone Number	

### Facility Diagram

A diagram of the proposed Operations building(s) and all materials storage areas will be included as an attachment in the final SPCC plan.

## Plan Certification

I \_\_\_\_\_ certify that the following is accurate:

1. I am familiar with the applicable requirements of 40 CFR part 112;
2. I have visited and examined the facility;
3. This Plan was prepared in accordance with accepted and sound industry practices and standards;
4. Procedures for required inspections and testing have been established in accordance with industry inspection and testing standards or recommended practices;
5. I will fully implement the Plan;
6. This facility meets the following qualification criteria (under §112.3(g)(1)):
  - a. The aggregate aboveground oil storage capacity of the facility is 10,000 U.S. gallons or less; and
  - b. The facility has had no single discharge as described in §112.1(b) exceeding 1,000 U.S. gallons and no two discharges as described in §112.1(b) each exceeding 42 U.S. gallons within any twelve month period in the three years prior to the SPCC Plan self-certification date, or since becoming subject to 40 CFR part 112 if the facility has been in operation for less than three years (not including oil discharges as described in §112.1(b) that are the result of natural disasters, acts of war, or terrorism); and
  - c. There is no individual oil storage container at the facility with an aboveground capacity greater than 5,000 U.S. gallons.
7. This Plan does not deviate from any requirement of 40 CFR part 112 as allowed by §112.7(a)(2) (environmental equivalence) and §112.7(d) (impracticability of secondary containment) or include any measures pursuant to §112.9(c)(6) for produced water containers and any associated piping;
8. This Plan and individual(s) responsible for implementing this Plan have the full approval of management and I have committed the necessary resources to fully implement this Plan.

I also understand my other obligations relating to the storage of oil at this facility, including, among others:

1. To report any oil discharge to navigable waters or adjoining shorelines to the appropriate authorities. Notification information is included in this Plan.
2. To review and amend this Plan whenever there is a material change at the facility that affects the potential for an oil discharge, and at least once every five years. Reviews and amendments are recorded in an attached log [See Five Year Review Log and Technical Amendment Log in Attachment D]

3. Optional use of a contingency plan. A contingency plan:

- a. May be used in lieu of secondary containment for qualified oil-filled operational equipment, in accordance with the requirements under §112.7(k), and;
- b. Must be prepared for flowlines and/or intra-facility gathering lines which do not have secondary containment at an oil production facility, and;
- c. Must include an established and documented inspection or monitoring program; must follow the provisions of 40 CFR part 109; and must include a written commitment of manpower, equipment and materials to expeditiously remove any quantity of oil discharged that may be harmful. If applicable, a copy of the contingency plan and any additional documentation will be attached to this Plan as Attachment 2.

I certify that I have satisfied the requirement to prepare and implement a Plan under §112.3 and all of the requirements under §112.6(a). I certify that the information contained in this Plan is true.

Signature: \_\_\_\_\_ Title: \_\_\_\_\_

Name Date: \_\_\_\_/\_\_\_\_/20\_\_\_\_

## 2. Record of Review & Reporting

The primary contact or designee shall administer this plan and will be responsible for updating and including any required documentation. This SPCC Plan will be amended when there is a change in the facility design, construction, operation, or maintenance that materially affects the potential for a discharge to navigable waters or adjoining shorelines. Examples include adding or removing containers, reconstruction, replacement, or installation of piping systems, changes to secondary containment systems, changes in product stored at this facility, or revisions to standard operating procedures. Any technical amendments to this Plan will be re-certified in accordance with Section 1 of this plan.

### **Plan Management (Five-Year Review)**

Complete a review and evaluation of this SPCC Plan at least once every five years. As a result of the review, amend this Plan within six months to include more effective prevention and control measures for the facility, if applicable. Implement any SPCC Plan amendment as soon as possible, but no later than six months following Plan amendment. Document completion of the review and evaluation, and complete the Five Year Review Log in Attachment D. If the facility no longer meets Tier I qualified facility eligibility, the owner or operator must revise the Plan to meet Tier II qualified facility requirements, or complete a full PE certified Plan

## 3. Plan Requirements

### **General Requirements**

The following describes general elements of the spill control plan at the facility:

- Ensure all hazardous substances are properly labeled.
- Store, dispense, and/or use hazardous substances in a way that prevents releases.
- Provide secondary containment when storing hazardous substances in bulk quantities (~55 g).
- Maintain good housekeeping practices for all chemical materials at the facility.
- Routine/Daily checks in the hazardous substance storage area to be performed by \_\_\_\_\_
- Monthly inspections of the hazardous substance storage area, secondary containment, and annular space (interior cavity of double wall tank) on any Above-ground Storage Tanks (AST) or Underground Storage Tanks (UST) need to be logged in this plan.

### **Facility Specific Requirements**

List all facility-specific requirements. Update facility-specific requirements as-needed.

- 
-







**Secondary Containment**

This table identifies the tanks and containers at the facility with the potential for an oil discharge; the mode of failure; the flow direction and potential quantity of the discharge; and the secondary containment method and containment capacity that is provided.

Area	Type of failure (discharge scenario)	Potential discharge volume (gallons)	Direction of flow for uncontained discharge	Secondary containment method <sup>a</sup>	Secondary containment capacity (gallons)
<b>Bulk Storage Containers and Mobile/Portable Containers<sup>b</sup></b>					
<b>Oil-filled Operational Equipment (e.g., hydraulic equipment, transformers)<sup>c</sup></b>					
<b>Piping, Valves, etc.</b>					
<b>Product Transfer Areas (location where oil is loaded to or from a container, pipe or other piece of equipment.)</b>					
<b>Other Oil-Handling Areas or Oil-Filled Equipment (e.g. flow-through process vessels at an oil production facility)</b>					

**a** Use one of the following methods of secondary containment or its equivalent: (1) Dikes, berms, or retaining walls sufficiently impervious to contain oil; (2) Curbing; (3) Culverting, gutters, or other drainage systems; (4) Weirs, booms, or other barriers; (5) Spill diversion ponds; (6) Retention ponds; or (7) Sorbent materials.

**b** For storage tanks and bulk storage containers, the secondary containment capacity must be at least the capacity of the largest container plus additional capacity to contain rainfall or other precipitation.

**c** For oil-filled operational equipment: Document in the table above if alternative measures to secondary containment (as described in §112.7(k)) are implemented at the facility.

## **Bulk Storage Containers**

Use of bulk storage containers at the facility will conform with the following requirements of 40 CFR 112:

- Secondary containment for the bulk storage containers (including mobile/portable oil storage containers) holds the capacity of the largest container plus additional capacity to contain precipitation. Mobile or portable oil storage containers are positioned to prevent a discharge as described in §112.1(b). [§112.6(a)(3)(ii)]
- Each aboveground bulk container is tested or inspected for integrity on a regular schedule and whenever material repairs are made. Scope and frequency of the inspections and inspector qualifications are in accordance with industry standards. Container supports and foundations are regularly inspected. [See Inspection Log and Schedule and Bulk Storage Container Inspection Schedule in Attachment A] [§112.8(c)(6) and §112.12(c)(6)(i)]
- Outsides of bulk storage containers are frequently inspected for signs of deterioration, discharges, or accumulation of oil inside diked areas. [See Inspection Log and Schedule in Attachment A] [§§112.8(c)(6) and 112.12(c)(6)]
- Each container is provided with a system or documented procedure to prevent overfills for the container. Describe:
  - Liquid level sensing devices are regularly tested to ensure proper operation [See Inspection Log and Schedule in Attachment A]. [§112.6(a)(3)(iii)]
  - Visible discharges which result in a loss of oil from the container, including but not limited to seams, gaskets, piping, pumps, valves, rivets, and bolts are promptly corrected and oil in diked areas is promptly removed. [§§112.8(c)(10) and 112.12(c)(10)]
  - Aboveground valves, piping, and appurtenances such as flange joints, expansion joints, valve glands and bodies, catch pans, pipeline supports, locking of valves, and metal surfaces are inspected regularly. [See Inspection Log and Schedule in Attachment A] [§§112.8(d)(4) and 112.12(d)(4)]

Bulk storage containers will be inspected according to the following schedule and a record of each inspection provided in the Inspection Log and Schedule in Attachment A.

Container Size and Design Specification	Inspection requirement
Portable containers (including drums, totes, and intermodal bulk containers (IBC))	Visually inspect monthly for signs of deterioration, discharges or accumulation of oil inside diked areas
55 to 1,100 gallons with sized secondary containment	Visually inspect monthly for signs of deterioration, discharges or accumulation of oil inside diked areas plus any annual inspection elements per industry inspection standards
1,101 to 5,000 gallons with sized secondary containment and a means of leak detection <sup>a</sup>	
1,101 to 5,000 gallons with sized secondary containment and no method of leak detection	Visually inspect monthly for signs of deterioration, discharges or accumulation of oil inside diked areas, plus any annual inspection elements and other specific integrity tests that may be required per industry inspection standards

<sup>a</sup> Examples of leak detection include, but are not limited to, double-walled tanks and elevated containers where a leak can be visually identified.

### Emergency Procedures

The following is a description of the immediate actions to be taken by facility personnel in the event of a discharge to navigable waters or adjoining shorelines:

- Immediately call **911** in the event of injury, fire or potential fire, or spill of a hazardous substance that gives rise to an emergency situation.
- If a spill has occurred, contact the Key Facility Contacts. Refer to the Facility Contacts Table on the following page.

In the event of a large spill, a properly trained employee should:

- Assess the area for any immediate dangers to health or safety (i.e. a wrecked car on fire). If any dangers are present, move away from the area, **call 911**.
- Notify the primary and/or secondary contact from the list above and then continue your spill response. The primary contact should assess additional notification requirements.
- Retrieve the spill kit from the closest location.
- Assess the size of the leak and any immediate threat of the spill reaching the floor/storm drains or permeable surfaces in the area. If there is an immediate threat and there are no safety concerns, then attempt to block the spill from coming in contact with the floor/storm drain or permeable surface. If no drain covers are available, then try to use

absorbent (cat litter) and/or sock booms or rags to stop the spill from getting into the drains or to any permeable surfaces.

- If the spill can be contained with absorbent booms, deploy them around the spill. Use the booms to direct the spill away from any immediate hazards (i.e. a wrecked car).
- If there is no immediate threat to the floor/storm drains or permeable surfaces, or after controlling the spill, try to plug or stop the leak, if possible. If applicable, put on protective gear (gloves, goggles, protective clothing, etc.) and plug the leak.
- Once the spill has been contained and any immediate threat to storm drains or permeable surfaces has been minimized, contact the spill cleanup contractor and dispatch them to clean up the spill or commence spill cleanup procedures.

Spill cleanup for large spills should be handled by the Spill Cleanup Contractor. Refer to the Facility Contacts Table on the following page.

<b>Facility Contacts List</b>	
<u>Contact Organization / Person</u>	<u>Telephone Number</u>
National Response Center (NRC)	1-800-424-8802
Cleanup Contractor(s)	
Key Facility Personnel	
Designated Person Accountable for Discharge Prevention:	
	Office:
	Emergency:
	Office:
	Emergency:
	Office:
	Emergency:
	Office:
	Emergency:
State Oil Pollution Control Agencies	
Oregon Emergency Response System	1-800- 452-0311
Other State, Federal, and Local Agencies	
Local Fire Department	
Local Police Department	
Hospital	
Other Contact References (e.g., downstream water intakes or neighboring facilities)	

## **Spill Reporting**

Notify the following agency(s) when the spill or threat of a spill includes:

- Any amount of oil to waters of the state (including surface water and storm drains);
- Oil spills on land in excess of 42 gallons;
- Hazardous materials and reportable quantities that are equal to the Code of Federal Regulations, 40 CFR Part 302.

Agency(s) to be contacted:

National Response Center (NRC)  
1-800-424-8802

Oregon Emergency Response System  
1-800- 452-0311

In the event of a discharge of oil to navigable waters or adjoining shorelines, the following information identified in Attachment 4 will be provided to the National Response Center immediately following identification of a discharge to navigable waters or adjoining shorelines [See Discharge Notification Form in Attachment C]:

- The exact address or location and phone number of the facility;
- Date and time of the discharge;
- Type of material discharged;
- Estimate of the total quantity discharged;
- Estimate of the quantity discharged to navigable waters;
- Source of the discharge;
- Description of all affected media;
- Cause of the discharge;
- Any damages or injuries caused by the discharge;
- Actions being used to stop, remove, and mitigate the effects of the discharge;
- Whether an evacuation may be needed; and
- Names of individuals and/or organizations who have also been contacted.

## **Spill Containment**

The general spill response procedure at this facility is to stop the source of the spill, contain any spilled material and clean up the spill in a timely manner to prevent accidental injury or other damage.

Small spills will be contained by site personnel if they are able to do so without risking injury. Spill kits are located at the following location(s):

List all spill kits and indicate their location on the Facility Diagram provided in Section 1.

**Facility Inspections**

Routine inspections will be conducted daily during regular business hours. Daily inspections will include, at a minimum, a visual inspection of the hazardous substances containers and the area immediately adjacent to it for signs of a spill or leak. These inspections do not need to be logged unless a spill or leak is detected. Ideally, these inspections will be conducted by a manager or by regular employees.

Full site inspections will be conducted monthly by the primary contact or designee and, at a minimum, will include those items on the Inspection Log. If any item on the inspection form is found unacceptable, the inspection form will be attached to this plan. If all items are deemed acceptable; it is sufficient for the inspector to log only the inspection and the results in the Inspection Log.

**Training**

All personnel who may respond to any spill, need to be trained on the contents and procedures in this plan. Trained personnel will add their names and dates of training to the Training Log [to be attached]. Only persons trained on this plan shall respond to a spill. If you are not trained and witness a spill, call or notify the primary and secondary contacts listed above.

The following table will be used to keep records of facility inspections, testing, and personnel training:

<b>Inspections, Testing, Recordkeeping and Personnel Training</b>	
An inspection and/or testing program is implemented for all aboveground bulk storage containers and piping at this facility. [§§112.8(c)(6) and (d)(4), 112.9(c)(3), 112.12(c)(6) and (d)(4)]	
The following is a description of the inspection and/or testing program (e.g. reference to industry standard utilized, scope, frequency, method of inspection or test, and person conducting the inspection) for all aboveground bulk storage containers and piping at this facility:	
Inspections, tests, and records are conducted in accordance with written procedures developed for the facility. Records of inspections and tests kept under usual and customary business practices will suffice for purposes of this paragraph. [§112.7(e)]	
A record of the inspections and tests are kept at the facility or with the SPCC Plan for a period of three years. [§112.7(e)] [See Inspection Log and Schedule in Attachment D]	
Inspections and tests are signed by the appropriate supervisor or inspector. [§112.7(e)]	
Personnel, training, and discharge prevention procedures [§112.7(f)]	
Oil-handling personnel are trained in the operation and maintenance of equipment to prevent discharges; discharge procedure protocols; applicable pollution control laws, rules, and regulations; general facility operations; and, the contents of the facility SPCC Plan. [§112.7(f)]	
A person who reports to facility management is designated and accountable for discharge prevention. [§112.7(f)] Name/Title:	
Discharge prevention briefings are conducted for oil-handling personnel annually to assure adequate understanding of the SPCC Plan for that facility. Such briefings highlight and describe past reportable discharges or failures, malfunctioning components, and any recently developed precautionary measures. [§112.7(f)] [See Oil-handling Personnel Training and Briefing Log in Attachment B]	



**Site Security**

Security measures will be implemented at this facility to prevent unauthorized access to oil handling, processing, and storage area.

The following is a description of how the facility will secure and control access to the oil handling, processing and storage areas; secure master flow and drain valves; prevent unauthorized access to starter controls on oil pumps; secure out-of service and loading/unloading connections of oil pipelines; address the appropriateness of security lighting to both prevent acts of vandalism and assist in the discovery of oil discharges:

**Spill Tracking (Recordkeeping)**

Any spills must be entered into the Discharge Log [Attachment C] and copies kept with this Plan. If a large catastrophic spill occurs, attach additional pages to describe the event. Include known or possible causes, areas affected, and effectiveness of the cleanup. Include a review of the cleanup contractor and their procedures. For small spills, it is sufficient to fill out the Spill Log, and to take measures to prevent a repeat occurrence.

## 4. Attachments

Attachment A – Inspection Log & Schedule

Attachment B – Materials Handling Personell Training and Briefing Log

Attachment C – Discharge Notification Form

Attachment D – Five Year Review Form





**Attachment C – Discharge Notification Form**

In the event of a discharge of oil to navigable waters or adjoining shorelines, the following information will be provided to the National Response Center [also see the notification information provided in Section 3 – Spill Reporting]:

Discharge/Discovery Date		Time	
Facility Name			
Facility Location (Address, Lat/Long, Section, Township, Range)			
Name of Reporting Individual		Telephone	
Type of Material Discharged		Estimated total quantity discharged	_____ (gallons)
Source of the discharge		Media Affected	<input type="checkbox"/> Soil
			<input type="checkbox"/> Water (specify)
			<input type="checkbox"/> Other (specify)
Actions Taken			
Damage or injuries	<input type="checkbox"/> No <input type="checkbox"/> Yes (specify)	Evacuation Needed?	<input type="checkbox"/> No <input type="checkbox"/> Yes (specify)
Organizations and individuals contacted	<input type="checkbox"/> National Response Center 800-424-8802 Time		
	<input type="checkbox"/> Cleanup contractor (Specify) Time		
	<input type="checkbox"/> Facility personnel (Specify) Time		
	<input type="checkbox"/> State Agency (Specify) Time		
	<input type="checkbox"/> Other (Specify) Time		

**Attachment D – Five Year Review Form**

In the event of a discharge of oil to navigable waters or adjoining shorelines, the following information will be provided to the National Response Center [also see the notification information provided in Section 3 – Spill Reporting]:

Table D.1 - Review and Evaluation of SPCC Plan for Facility			
Review Date	Plan Amendment		Name and signature of person authorized to review this Plan
	Will Amend	Will Not Amend	
	<input type="checkbox"/>	<input type="checkbox"/>	
	<input type="checkbox"/>	<input type="checkbox"/>	
	<input type="checkbox"/>	<input type="checkbox"/>	
	<input type="checkbox"/>	<input type="checkbox"/>	
	<input type="checkbox"/>	<input type="checkbox"/>	
	<input type="checkbox"/>	<input type="checkbox"/>	
	<input type="checkbox"/>	<input type="checkbox"/>	
	<input type="checkbox"/>	<input type="checkbox"/>	
	<input type="checkbox"/>	<input type="checkbox"/>	
	<input type="checkbox"/>	<input type="checkbox"/>	



