

Model ATC Controller

DRAWER

1	2	3	4	5	6	7	8	9	10	11	12	13	14
1 E,C MT1 C1-56	2 E,C C1-39 MT2 MT3	2 E,C C1-63 MT4 MT5	2 C MT6 C1-47	3 E,C MT7 C1-58	4 E,C C1-41 MT8 MT9	4 E,C C1-65 MT10 MT11	4 C MT12 C1-49	1 E,C C1-60 MT13 MT14			2 Ped C1-67	6 Ped C1-68	
1 E,C C1-43 2 E,C		C1-76 2 E	2 C	3 E,C	C1-45 4 E,C	C1-78 4 E	4 C	C1-62 3 E,C			4 Ped C1-69	C1-70	8 Ped
1	2	3	4	5	6	7	8	9	10	11	12	13	14
5 E,C MT15 C1-55	6 E,C C1-40 MT16 MT17	6 E,C C1-64 MT18 MT19	6 C MT20 C1-48	7 E,C MT21 C1-57	8 E,C C1-42 MT22 MT23	8 E,C C1-66 MT24 MT25	8 C MT26 C1-50	5 E,C C1-59 MT27 MT28			C1-54 C1-75	EVA C1-71	EVB C1-72
5 E,C	6 E,C C1-44 6 E,C	C1-77 6 E	6 C	7 E,C	C1-46 8 E,C	C1-79 8 E	8 C	C1-61 7 E,C			EVC	C1-73	EVD C1-74

Channel 1
Input File "I"
Channel 2

Channel 1
Input File "J"
Channel 2

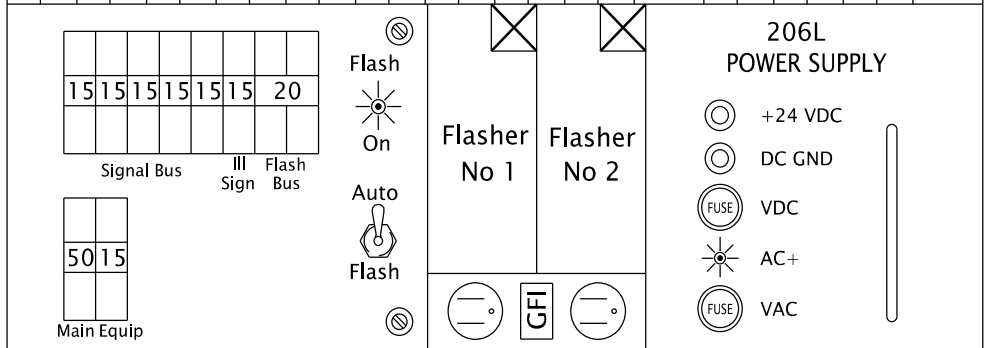

Power Distribution Assembly #2

FTR-1	1	2	3	4	5	6	
Ph	Ph	Ph	Ped	Ph	Ph	Ped	Conflict Monitor
SC1	SC1	SC1	SC2	SC2	SC2		
FTR-3	7	8	9	10	11	12	
Ph	Ph	Ped	Ph	Ph	Ped		
FTR-4	SC3	SC3	SC3	SC4	SC4	SC4	

Output File

FTR-5	FTR-6	A1	A2	A3	A4	A5	A6
		SC5	SC5	SC5	SC5	SC5	SC5

Auxiliary Output File (Typical)

SC=Signal Circuit

REV. NO.	DATE	INITIAL	REMARKS
1	01/23	JS	UPDATED CMU, ADD 9,10,11,12 YELLOWS

INTERSECTION: **Main Street @ Cross Street**
 Any Town
 HWY#: XXX M.P.#: XXX.XX TSSU ID#: XXXXX

OREGON DEPARTMENT OF TRANSPORTATION
 TRAFFIC - ROADWAY SECTION
332 CABINET WIRING DIAGRAM
 REV 01/04/23

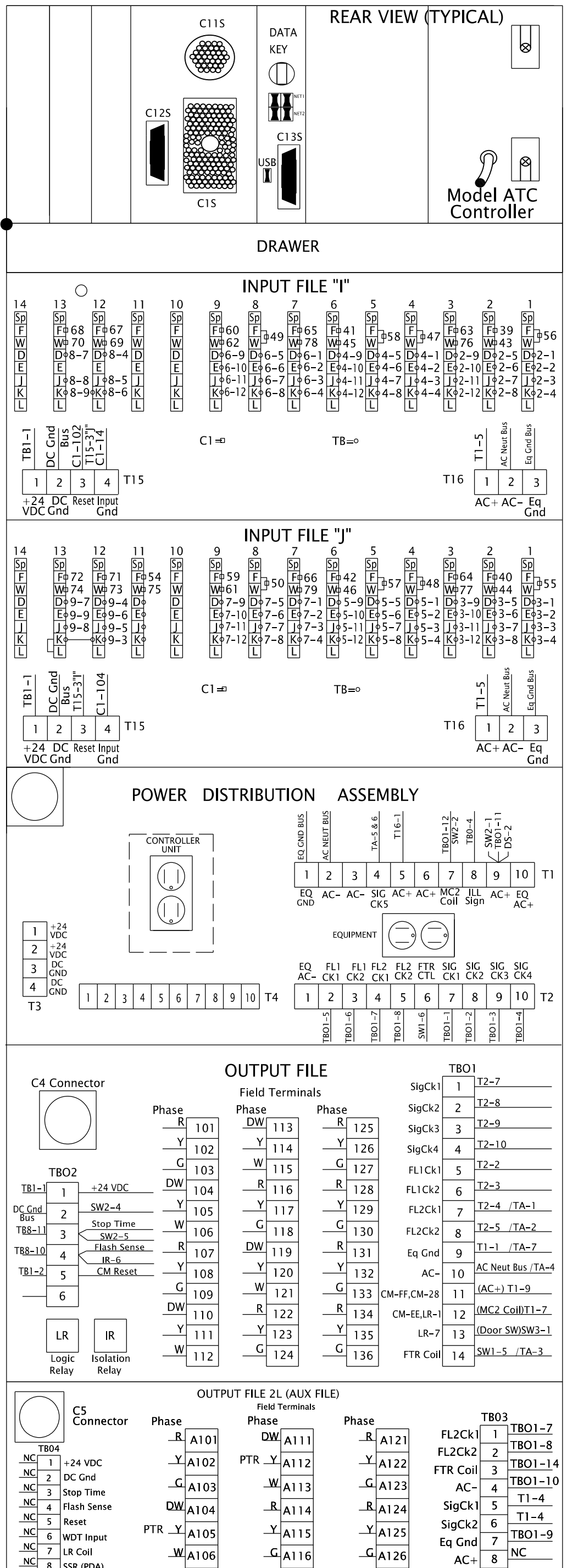
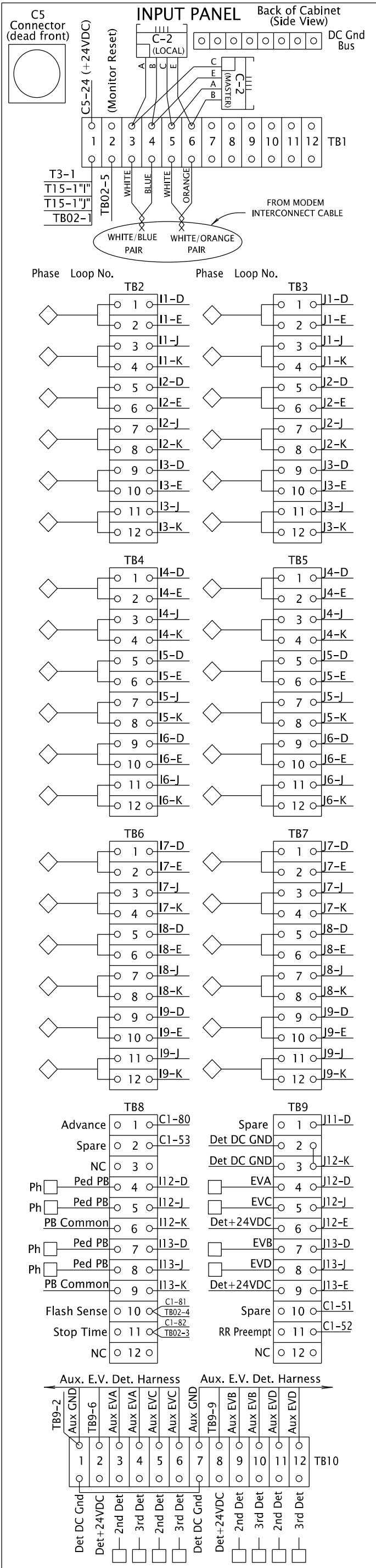

INTERSECTION: **Main Street @**
Cross Street
Any Town
 HWY#: XXX M.P.#: XXX.XX TSSU ID#: XXXXX

PROGRAM PIN ASSIGNMENTS

Program Assigned Functions	C1 Connector		C4 Connector				Field Term.
	Pin	Termination	Pin	Switch Pack			
				In	Position	Out	
DC Gnd	1	DC Gnd Bus	-	-	-	-	-
Ø4 D.WALK	2	C4-1	1	6	6-DW	3	104
Ø4 WALK	3	C4-2	2	10	6-W	7	106
Ø4 RED	4	C4-3	3	6	5-R	3	101
Ø4 YELLOW	5	C4-4	4	8	5-Y	5	102
Ø4 GREEN	6	C4-5	5	10	5-G	7	103
Ø3 RED	7	C4-6	6	6	4-R	3	116
Ø3 YELLOW	8	C4-7	7	8	4-Y	5	117
Ø3 GREEN	9	C4-8	8	10	4-G	7	118
Ø2 D.WALK	10	C4-9	9	6	3-DW	3	113
Ø2 WALK	11	C4-10	10	10	3-W	7	115
2 RED	12	C4-11	11	6	2-R	3	128
2 YELLOW	13	C4-12	12	8	2-Y	5	129
Input Gnd	14		-	-	-	-	-
Ø2 GREEN	15	C4-13	13	10	2-G	7	130
Ø1 RED	16	C4-14	14	6	1-R	3	125
Ø1 YELLOW	17	C4-15	15	8	1-Y	5	126
Ø1 GREEN	18	C4-16	16	10	1-G	7	127
Ø8 D.WALK	19	C4-17	17	6	12-DW	3	110
Ø8 WALK	20	C4-18	18	10	12-W	7	112
Ø8 RED	21	C4-19	19	6	11-R	3	107
Ø8 YELLOW	22	C4-20	20	8	11-Y	5	108
Ø8 GREEN	23	C4-21	21	10	11-G	7	109
Ø7 RED	24	C4-22	22	6	10-R	3	122
Ø7 YELLOW	25	C4-23	23	8	10-Y	5	123
Ø7 GREEN	26	C4-24	24	10	10-G	7	124
Ø6 D.WALK	27	C4-25	25	6	9-DW	3	119
Ø6 WALK	28	C4-26	26	10	9-W	7	121
Ø6 RED	29	C4-27	27	6	8-R	3	134
Ø6 YELLOW	30	C4-28	28	8	8-Y	5	135
Ø6 GREEN	31	C4-29	29	10	8-G	7	136
Ø5 RED	32	C4-30	30	6	7-R	3	131
Ø5 YELLOW	33	C4-31	31	8	7-Y	5	132
Ø5 GREEN	34	C4-32	32	10	7-G	7	133
(A) TOD/DOW	35	C4-33	33	8	3-Y	5	114
(B) TOD/DOW	36	C4-34	34	8	9-Y	5	120
(C)TOD/DOW	37	C4-35	35	8	6-Y	5	105
(D)TOD/DOW	38	C4-36	36	8	12-Y	5	111

Program Assigned Functions	C1 Connector		C5 Connector				Field Term.
	Pin	Termination	Pin	Switch Pack			
				In	Position	Out	
Ø3 D.WALK	83	C5-1	1	6	A6-DW	3	A104
Ø3 WALK	84	C5-2	2	10	A6-W	7	A106
OLD RED	85	C5-3	3	6	A5-R	3	A101
OLD YELLOW	86	C5-4	4	8	A5-Y	5	A102
OLD GREEN	87	C5-5	5	10	A5-G	7	A103
OLC RED	88	C5-6	6	6	A4-R	3	A114
OLC YELLOW	89	C5-7	7	8	A4-Y	5	A115
OLC GREEN	90	C5-8	8	10	A4-G	7	A116
Ø1 D.WALK	91	C5-9	9	6	A3-DW	3	A111
DC Gnd	92	DC Gnd Bus	-	-	-	-	-
Ø1 WALK	93	C5-10	10	10	A3-W	7	A113
OLB RED	94	C5-11	11	6	A2-R	3	A124
OLB YELLOW	95	C5-12	12	8	A2-Y	5	A125
OLB GREEN	96	C5-13	13	10	A2-G	7	A126
OLA RED	97	C5-14	14	6	A1-R	3	A121
OLA YELLOW	98	C5-15	15	8	A1-Y	5	A122
OLA GREEN	99	C5-16	16	10	A1-G	7	A123
NOT ASSIGN	100	C5-17	17	8	A6-Y	5	A105
NOT ASSIGN	101	C5-18	18	8	A3-Y	5	A112

FLASH OUT	102	T15-3"1"				
Watchdog	103	C4-37	Monitor-Pin 22			
Input Gnd	104	T15-4"J"				

19	-	NC	-	-
20	-	NC	-	-
21	-	NC	-	-
22	-	NC	-	-
23	-	NC	-	-
24	TB1-1	All	9	+24VDC

Program Assigned Functions	C1 Connector		Input Files		
	Pin	Termination	Terminals		Field Terminals
			Out	In	
Ø2 DET,E&C	39	I2-1	F	D&E	TB2-5&6
Ø6 DET,E&C	40	J2-1	F	D&E	TB3-5&6
Ø4 DET,E&C	41	I6-1	F	D&E	TB4-9&10
Ø8 DET,E&C	42	J6-1	F	D&E	TB5-9&10
Ø2 DET,E&C	43	I2-2	W	J&K	TB2-7&8
Ø6 DET,E&C	44	J2-2	W	J&K	TB3-7&8
Ø4 DET,E&C	45	I6-2	W	J&K	TB4-11&12
Ø8 DET,E&C	46	J6-2	W	J&K	TB5-11&12
Ø2 DET, C	47	I4-1&2	F&W	DE&JK	TB4-1,2&3,4
Ø6DET, C	48	J4-1&2	F&W	DE&JK	TB5-1,2&3,4
Ø4 DET, C	49	I8-1&2	F&W	DE&JK	TB6-5,6&7,8
Ø8 DET, C	50	J8-1&2	F&W	DE&JK	TB7-5,6&7,8
PED INHIBIT	51	-	-	-	TB9-10
RR Preempt	52	-	-	-	TB9-11
ADV ENABLE	53	-	-	-	TB8-2
NOT ASSIGN	54	J11-1	F	D	TB9-1
Ø5 DET,E&C	55	J1-1&2	F&W	DE&JK	TB3-1,2&3,4
Ø1 DET,E&C	56	I1-1&2	F&W	DE&JK	TB2-1,2&3,4
Ø7 DET,E&C	57	J5-1&2	F&W	DE&JK	TB5-5,6&7,8
Ø3 DET,E&C	58	I5-1&2	F&W	DE&JK	TB4-5,6&7,8
Ø5 DET,E&C	59	J9-1	F	D&E	TB7-9&10
Ø1 DET,E&C	60	I9-1	F	D&E	TB6-9&10
Ø7 DET,E&C	61	J9-2	W	J&K	TB7-11&12
Ø3 DET,E&C	62	I9-2	W	J&K	TB6-11&12
Ø2 DET,E&C	63	I3-1	F	D&E	TB2-9&10
Ø6 DET,E&C	64	J3-1	F	D&E	TB3-9&10
Ø4 DET,E&C	65	I7-1	F	D&E	TB6-1&2
Ø8 DET,E&C	66	J7-1	F	D&E	TB7-1&2
Ph 2 Ped	67	I12-1	F	D	TB8-4
Ph 6 Ped	68	I13-1	F	D	TB8-7
Ph 4 Ped	69	I12-2	W	J	TB8-5
Ph 8 Ped	70	I13-2	W	J	TB8-8
EVA	71	J12-1	F	D	TB9-4
EVB	72	J13-1	F	D	TB9-7
EVC	73	J12-2	W	J	TB9-5
EVD	74	J13-2	W	J	TB9-8
NOT ASSIGN	75	J11-2	W	J	-
Ø2 DET, E	76	I3-2	W	J&K	TB2-11&12
Ø6 DET, E	77	J3-2	W	J&K	TB3-11&12
Ø4 DET, E	78	I7-2	W	J&K	TB6-3&4
Ø8 DET, E	79	J7-2	W	J&K	TB7-3&4
Advance	80	-	-	-	TB8-1
Flash Sense	81	-	-	-	TB8-10
Stop Time	82	-	-	-	TB8-11

CONFLICT MONITOR - TYPICAL CONNECTOR PIN ASSIGNMENTS

Term	Function	Pin	Pin	Function	Term
130	SP2-G	1	A	SP2-Y	129
115	SP3-W	2	B	SP8-G	136
135	SP8-Y	3	C	SP9-W	121
103	SP5-G	4	D	SP5-Y	102
106	SP6-W	5	E	SP11-G	109
108	SP-11Y	6	F	SP12-W	112
133	SP7-G	7	H	SP7-Y	132
114	SP3-Y	8	J	SP1-G	127
126	SP1-Y	9	K	SP9-Y	120
124	SP10-G	10	L	SP10-Y	123
105	SP6-Y	11	M	SP4-G	118
117	SP4-Y	12	N	SP12-Y	111
A123	ASP1-G	13	P	NC	-
-	NC	14	R	ASP2-G	A126
A115	ASP4-Y	15	S	ASP4-G	A116
A122	ASP1-Y	16	T	NC	-
-	NC	17	U	ASP2-Y	A125
A102	ASP5-Y	18	V	ASP5-G	A103
-	NC	19	W	NC	-
TB01-9	EQ Gnd	20	X	NC	-
TB01-10	AC-	21	Y	DC Gnd	TB02-2
C4-37	Watch Dog	22	Z	Ext. Reset	TB02-5
TB02-1	+24VDC	23	AA	T&B	-
LRCoIL	Interlock	24	BB	Stop Time	TB02-3
TB02-2	Interlock	25	CC	NC	-
-	NC	26	DD	NC	-
-	NC	27	EE	Clapper	TB01-12
TB01-11	Norm. Closed	28	FF	AC+	TB01-11

Ch	PH
1	1
2	2
3	3
4	4
5	5
6	6
7	7
8	8
9	OLA, Ø1FYA/YA
10	OLB, Ø3FYA/YA
11	OLC, Ø5FYA/YA
12	OLD, Ø7FYA/YA
13	2PED
14	4PED
15	6PED
16	8PED

T&B= Tied & Bundled

CONFLICT MONITOR

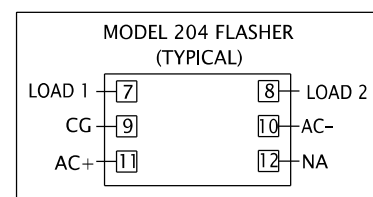
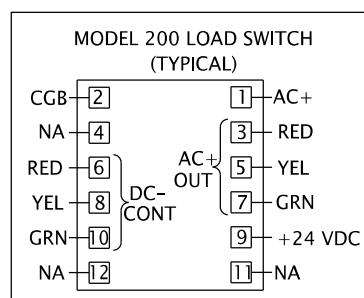

INTERSECTION: **Main Street @**
Cross Street
Any Town
HWY#: XXX M.P.#: XXX.XX TSSU ID#: XXXXX

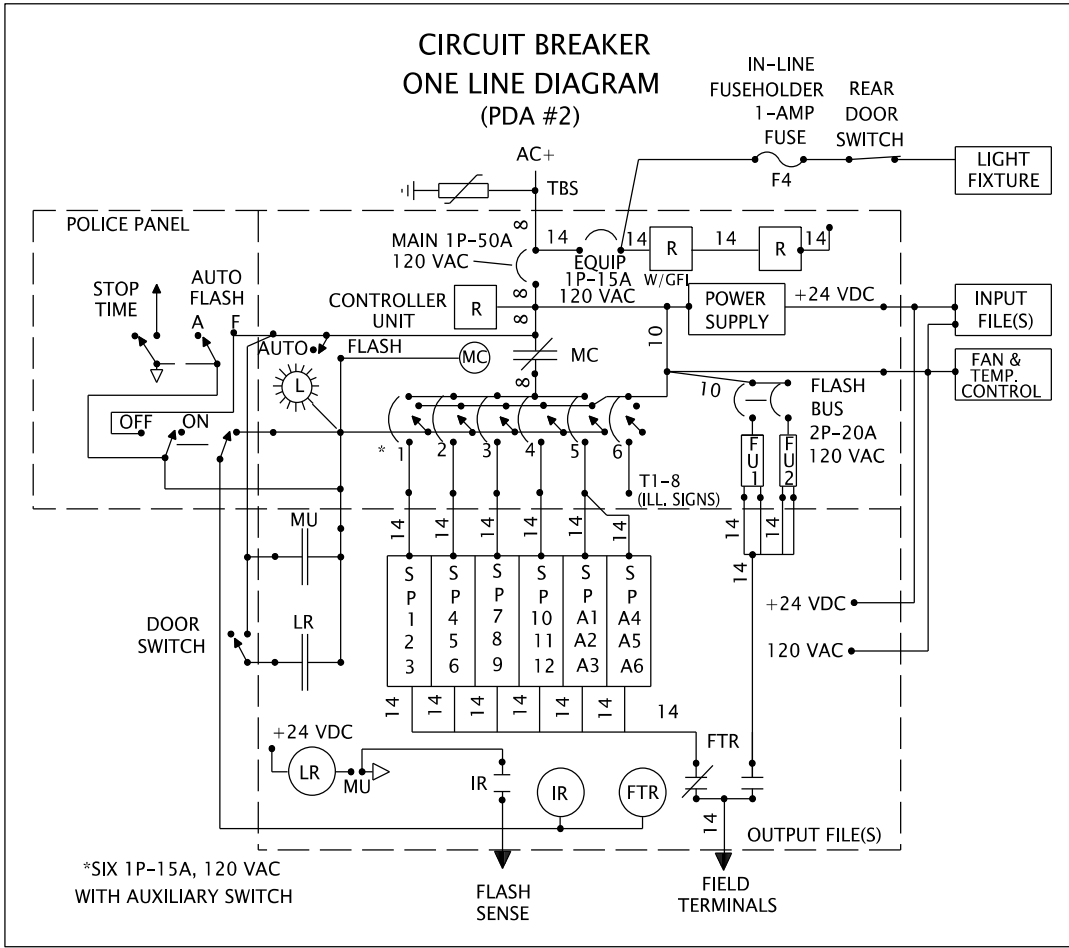

- SURGE PROTECTORS
- TBS TERMINAL BLOCK-SERVICE
- EQUIPMENT GROUND
- PDA POWER DISTRIBUTION ASSEMBLY
- WIRE SIZE, IF NOT INDICATED SHALL BE # 14 AWG
- CIRCUIT BREAKER
- DUPLEX RECEPTACLE
- W/GFI WITH GROUND FAULT INTERRUPTER
- RELAY CONTACT, NORMALLY CLOSED
- RELAY CONTACT, NORMALLY OPEN
- MC MERCURY CONTACTOR
- RELAY COIL-- RELAY NAME
- DC GROUND
- FLASHER UNIT ONE
- FLASH RELAY
- WDT WATCHDOG TIMER
- FTR FLASH TRANSFER RELAY
- PDA FLASH ON DISPLAY LAMP
- DR SW DOOR SWITCH, SHOWN WITH DOOR OPEN
- CB-1 SIGNAL CIRCUIT BREAKER 1 (SECONDARY)
- TR TRANSFER RELAY
- IR ISOLATION RELAY
- LR LOGIC RELAY
- IFI-14D INPUT FILE "I", TERM BLOCK "14", POSITION "D"

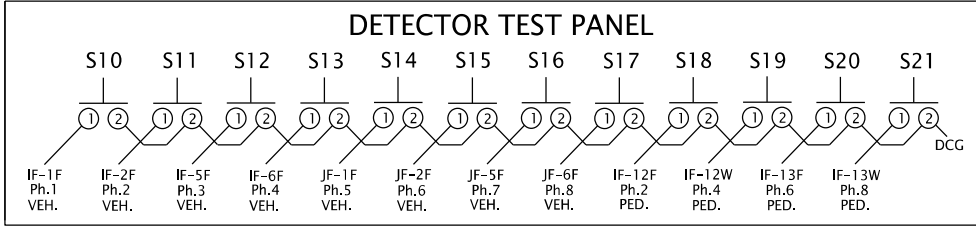
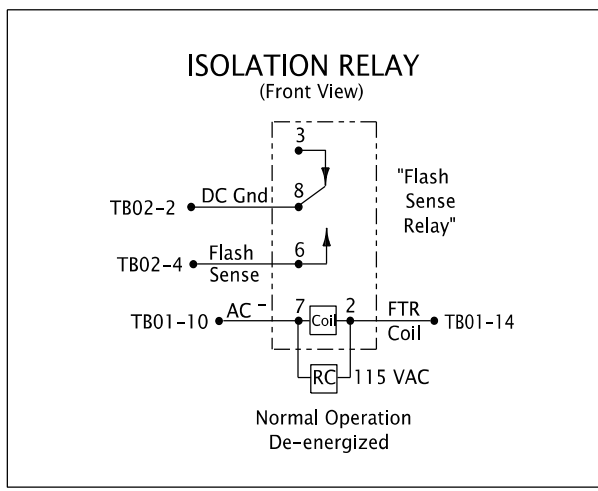
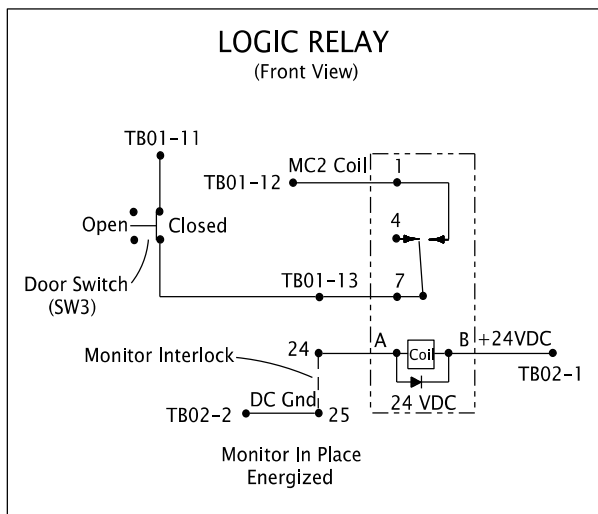
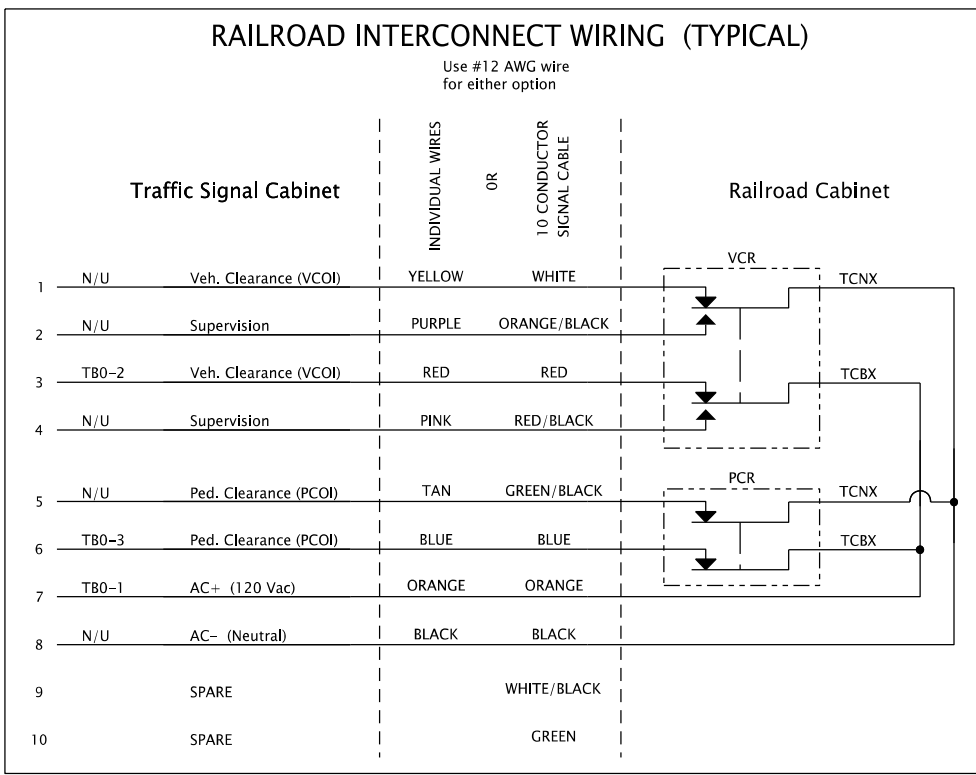
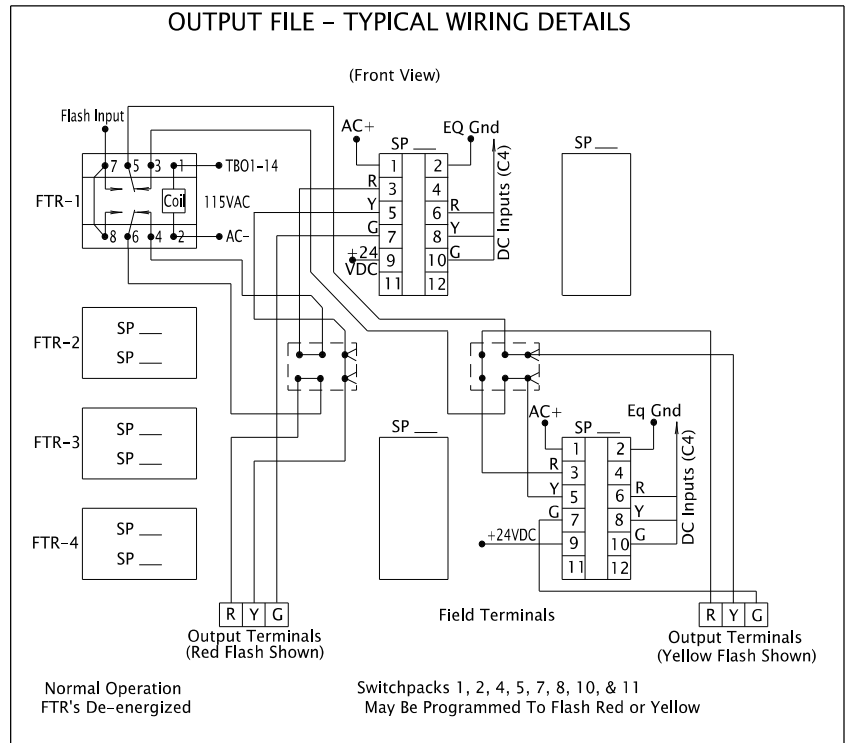
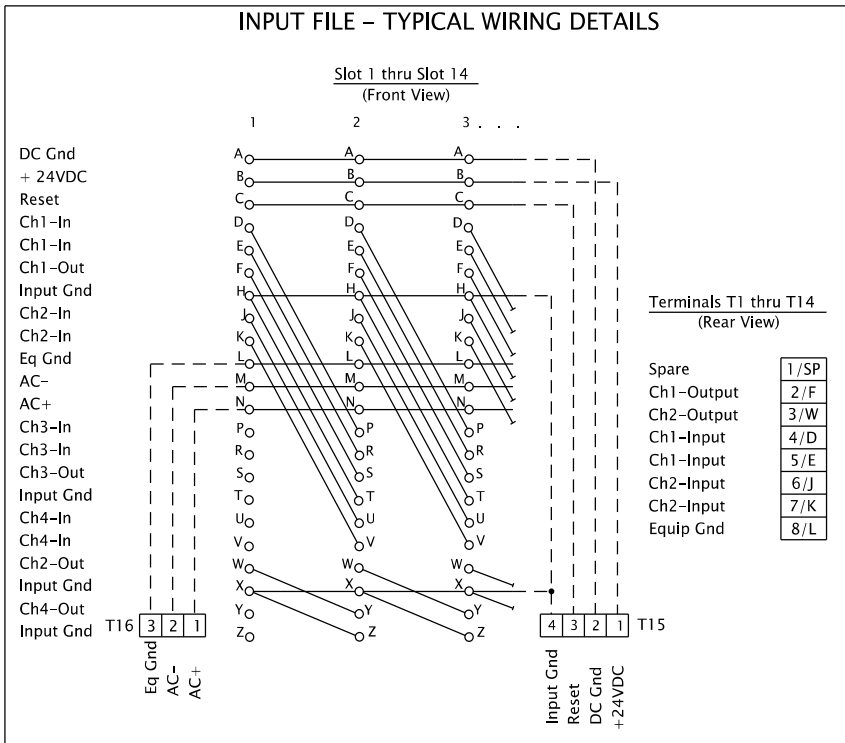

INTERSECTION: **Main Street @**
Cross Street
Any Town
HWY#: XXX M.P.#: XXX.XX TSSU ID#: XXXXX

Place Intersection Diagram, phase and Fire rotations,
and any other applicable information on this sheet.

INTERSECTION: Main Street @
Cross Street Any Town
HWY#: XXX M.P.#: XXX.XX TSSU ID#: XXXXX

Have Agency Signal Techs or Electricians Verify the Diode Card Information If You Are Not Sure.

REMOVE ALL INFORMATION ABOVE DIODE CARD WHEN PRINT IS COMPLETED

NOTE:

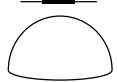
1. FILL IN CHANNEL ASSIGNMENTS WITH PHASING. Ch.1 Ph 1, Ph 5, OLA, Ped 2, NU
2. REMOVE YELLOW INHIBIT JUMPERS AS NEEDED. —
3. REMOVE DIODES FOR ALLOWED PHASING. —
4. PLACE SHAPE AROUND REMOVED DIODES. 

CONFLICT MONITOR DIODE CARD

CHANNEL ASSIGNMENT

Ch.1 <u> </u> Ph 1 <u> </u>	Ch.5 <u> </u> Ph 5 <u> </u>	Ch.9 Ph 1 FYA/YA <u> </u>	Ch.13 <u> </u> Ped 2 <u> </u>
Ch.2 <u> </u> Ph 2 <u> </u>	Ch.6 <u> </u> Ph 6 <u> </u>	Ch.10 Ph 3 FYA/YA <u> </u>	Ch.14 <u> </u> Ped 4 <u> </u>
Ch.3 <u> </u> Ph 3 <u> </u>	Ch.7 <u> </u> Ph 7 <u> </u>	Ch.11 Ph 5 FYA/YA <u> </u>	Ch.15 <u> </u> Ped 6 <u> </u>
Ch.4 <u> </u> Ph 4 <u> </u>	Ch.8 <u> </u> Ph 8 <u> </u>	Ch.12 PH 7 FYA/YA <u> </u>	Ch.16 <u> </u> Ped 8 <u> </u>

YELLOW INHIBIT JUMPERS

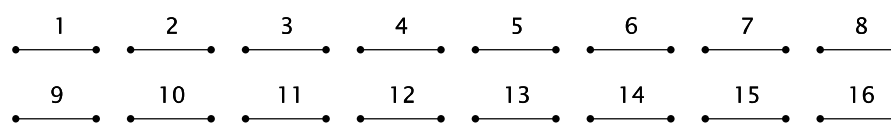

DIODES - Diode Removed Makes Movement Allowable (Diode IN4148)

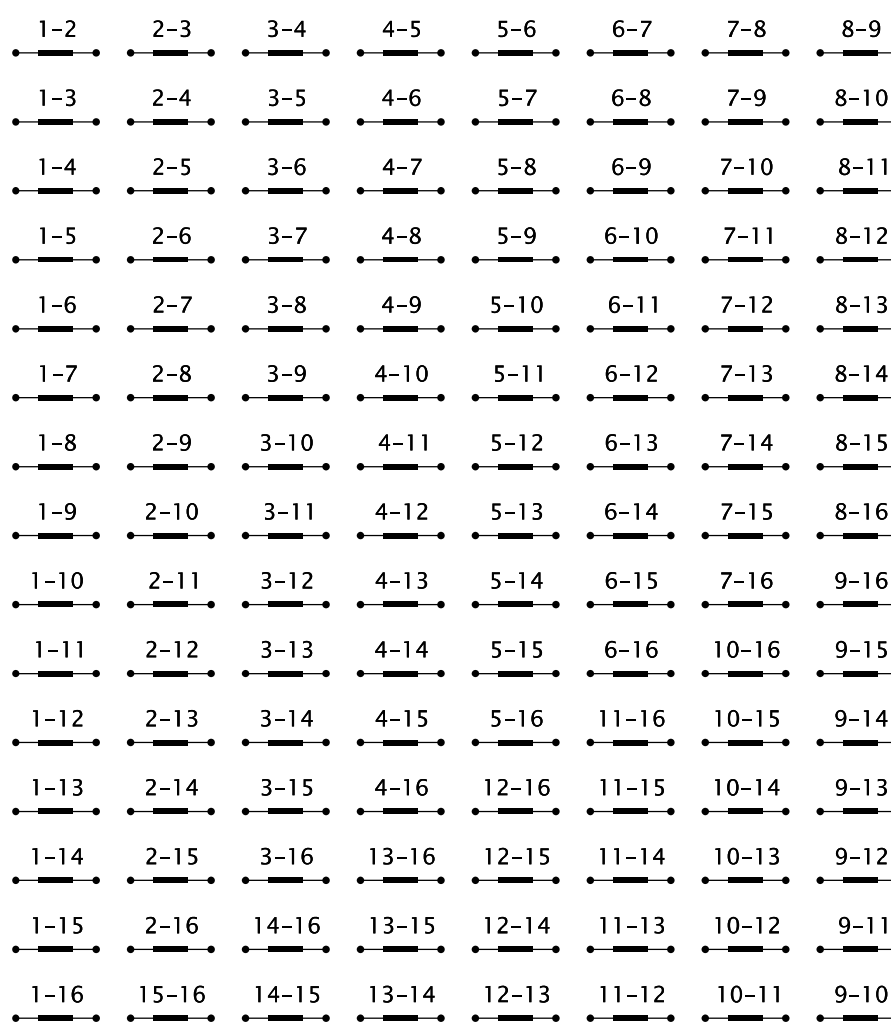

INTERSECTION: Main Street @
Cross Street
Any Town
 HWY#: XXX M.P.#: XXX.XX TSSU ID#: XXXXX