



**SELF-ISSUE  
PERMIT PROGRAM  
(SIPP)**



# Self-Issue Permit Program

Presented by  
Charles A. Hutto

Commerce and Compliance Division  
Over-Dimension Permit Unit



## Housekeeping

- Please mute your microphone in the Teams application if you are using the application as your visual and calling in via phone for your audio.
- Please mute your microphone if you are not speaking.
- Please do not put the call on hold.



## Introduction & General Overview

- Welcome and introductions.
- Training outline and discussion.
  - **What's Legal?**
  - **What's Permittable?**
  - Routing considerations.
  - Pilot vehicles and road restrictions.
- Permit samples.
- Decertification.
- Q & A.





## Dimensions Allowed

### Width

- 12 feet wide on **green** and **purple** routes on Route Map 2.
- 14 feet wide on black routes on [Route Map 9](#) (or Route Map 6 for mobile/modular units).

### Height

- 15 feet high, subject to vertical clearance routing.





## Dimensions Allowed

### Weight (non-divisible)

- 21,500 pounds per single axle.
- 43,000 pounds per tandem axle.
- 200,000 pounds gross weight.
- Tire, axle and group axle weights shown in [Weight Table 4](#).

### Weight (divisible)

- 20,000 pounds per single axle.
- 34,000 pounds per tandem axle.
- 80,000 pounds gross weight.
- Tire, axle and group axle weights shown in [Weight Table 1](#).
  - Can use in conjunction with a valid extended weight permit.





## Dimensions Allowed

### Overall Length

- 120 feet overall length for heavy haul combinations.
- 110 feet overall length when towing a mobile home or hauling a modular unit.
- 105 feet overall length for truck tractor/semitrailer combinations.
- 50 feet overall length for solo vehicles.





## Dimensions Allowed

### Trailer Length

- Up to 53 feet fixed in a truck tractor/semitrailer combination.
- Up to 62 feet fixed in a heavy haul combination.
- Up to 65 feet expanded or stretched.
- Up to 75 feet stretch when hauling a modular unit.







## Currently NOT Allowed

Currently, the following combination types are NOT allowed in SIPP:

- Truck & Trailer.
- Pickup and Trailer.

Currently, the following permit types are NOT allowed in SIPP:

- **“Emergency” moves.**
- Legalization permits.
- 30-day permits.





## The Goal

- A successful self-issue permits program that:
- Protects the safety of the traveling public.
  - Protects the infrastructure of the State of Oregon.
  - Voluntary compliance through education.





# What's Legal?





# Solo Vehicle

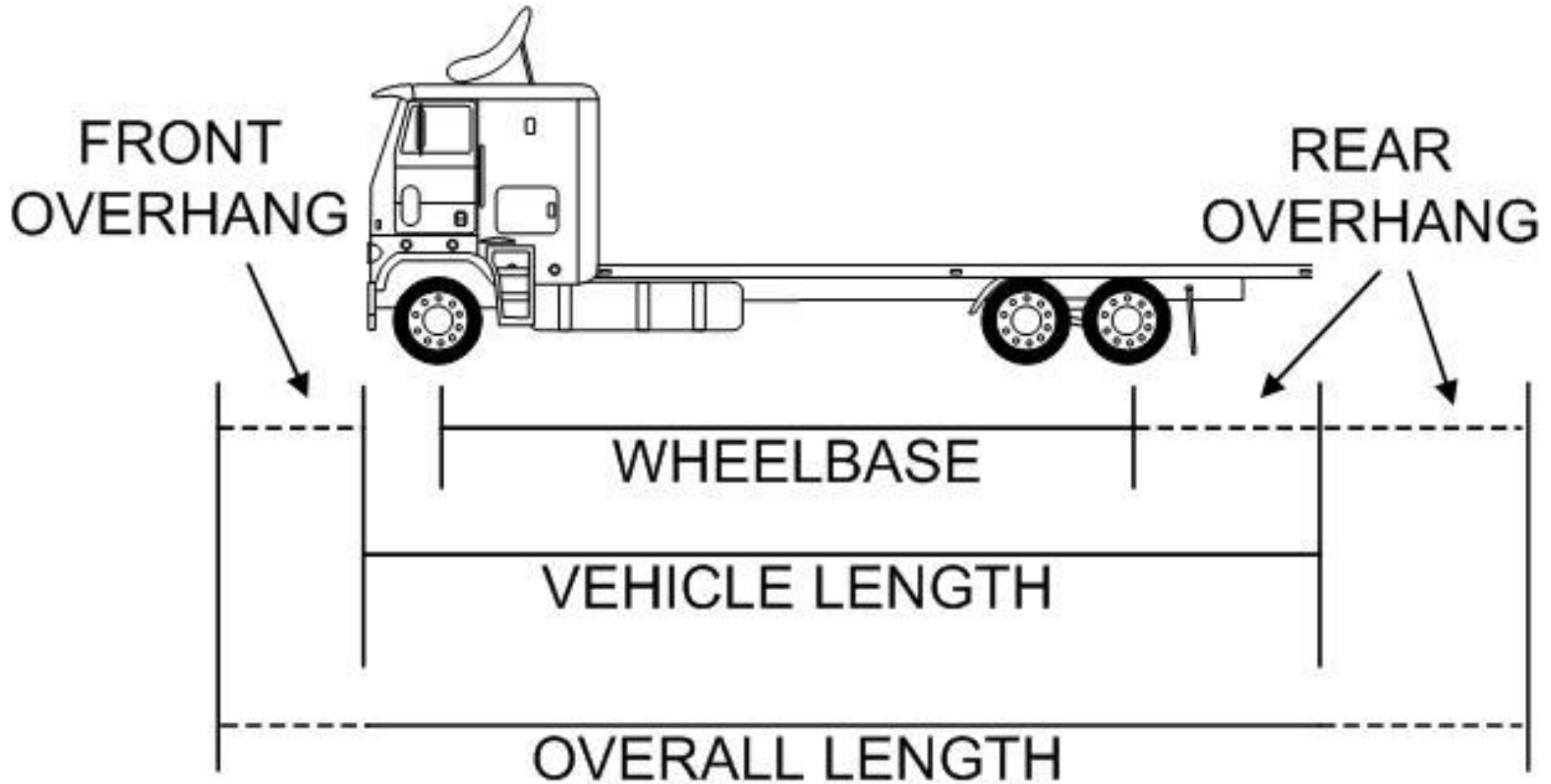



## Solo Vehicle – What's Legal?

- Width: 8'06".
- Height (including load): 14'00".
- Front overhang: 4 feet.
- Rear Overhang: 3/4 wheelbase.
- Load length: 40 feet.
- Overall length: 40 feet, including load.
  - Exception - Recreational Vehicle: 45 feet.





# Truck Tractor / Semitrailer

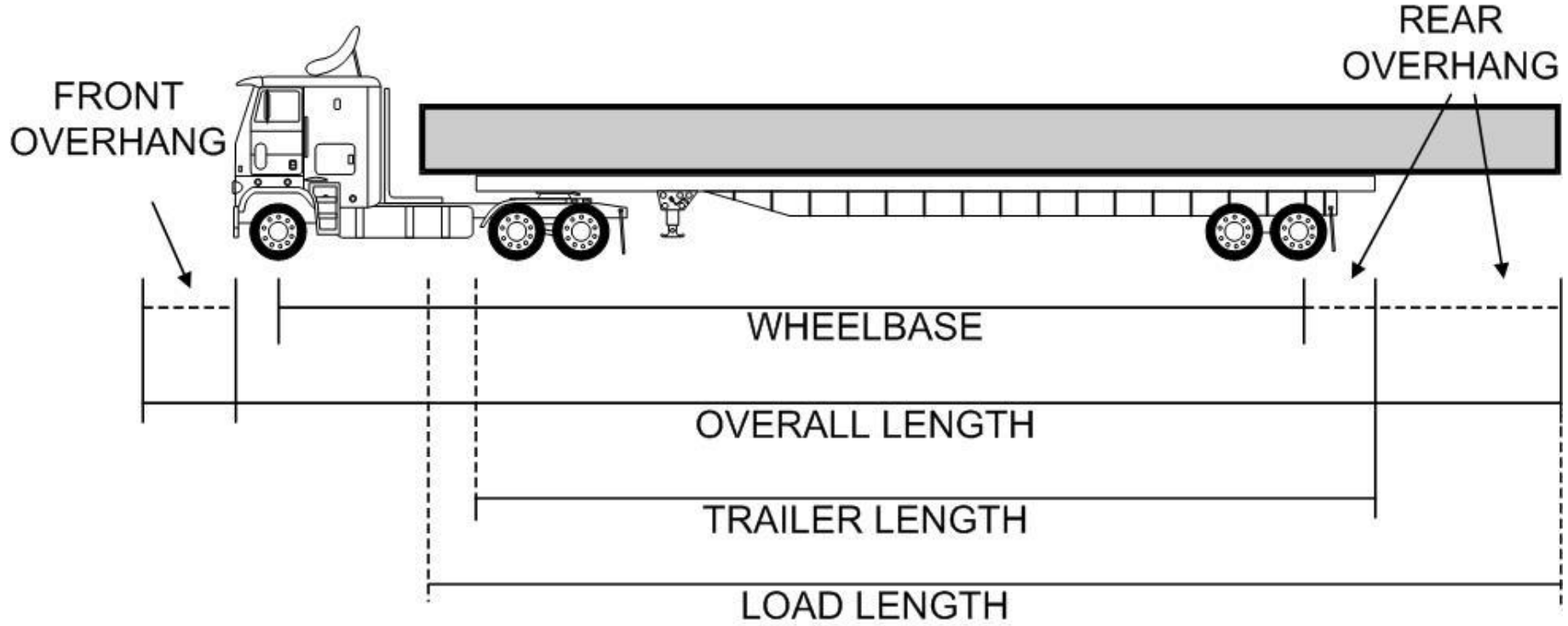



## Truck Tractor / Semitrailer – What's Legal?

- Width: 8'06".
- Height (including load): 14'00".
- Front overhang: 4 feet.
- Rear Overhang: 5 feet off the back of the trailer (in most cases).





# Combinations – What's Legal? (Continued)

- Refer to the back of [Route Map 1](#) for legal trailer and combination lengths.
- Refer to the back of [Route Map 7](#) for allowed trailer and combination lengths for:
  - Truck tractor / semitrailer combinations.
  - Doubles combinations.
  - Pickup and trailer combinations.



## Weight

With few exceptions, carriers are not allowed to exceed the following weights:

- **Tire manufacturer's sidewall rating.**
- 600 pounds per inch of tire width.
- Single axle weight:
  - 20,000 pounds for a divisible load.
  - 21,500 pounds for a non-divisible load.
- Tandem axle weight:
  - 34,000 pounds for a divisible load.
  - 43,000 pounds for a non-divisible load.
- The sum of the permissible axle, tandem axle, or group axle weights shown in the appropriate weight table.



## Weight

Permit is required when operating at [Weight Table 2](#) or higher. Examples:

- Annual Extended Weight Permit for Weight Table 2 (up to 105,500 pounds gross weight on legal axle and group axle weights).
- Annual heavy haul permit for [Weight Table 3](#), up to 98,000 pounds gross weight.
- Single-trip permits for movement of a non-divisible load:
  - Heavy haul axle and group axle weights (Weight Table 3 or higher).
  - Gross weight of 98,000 pounds or greater.





## Legal Weight

- The loaded weight of any group of axles, vehicle, or combination of vehicles shall not exceed any of the following:
  - 600 pounds per inch of tire width.
  - 20,000 pounds per single axle.
  - 34,000 pounds per tandem axle.
  - 80,000 pounds gross weight.
  - The sum of the permissible axle, tandem axle, or group of axle weights shown in [Weight Table 1](#), whichever is less.





# Weight Table 1 Sample

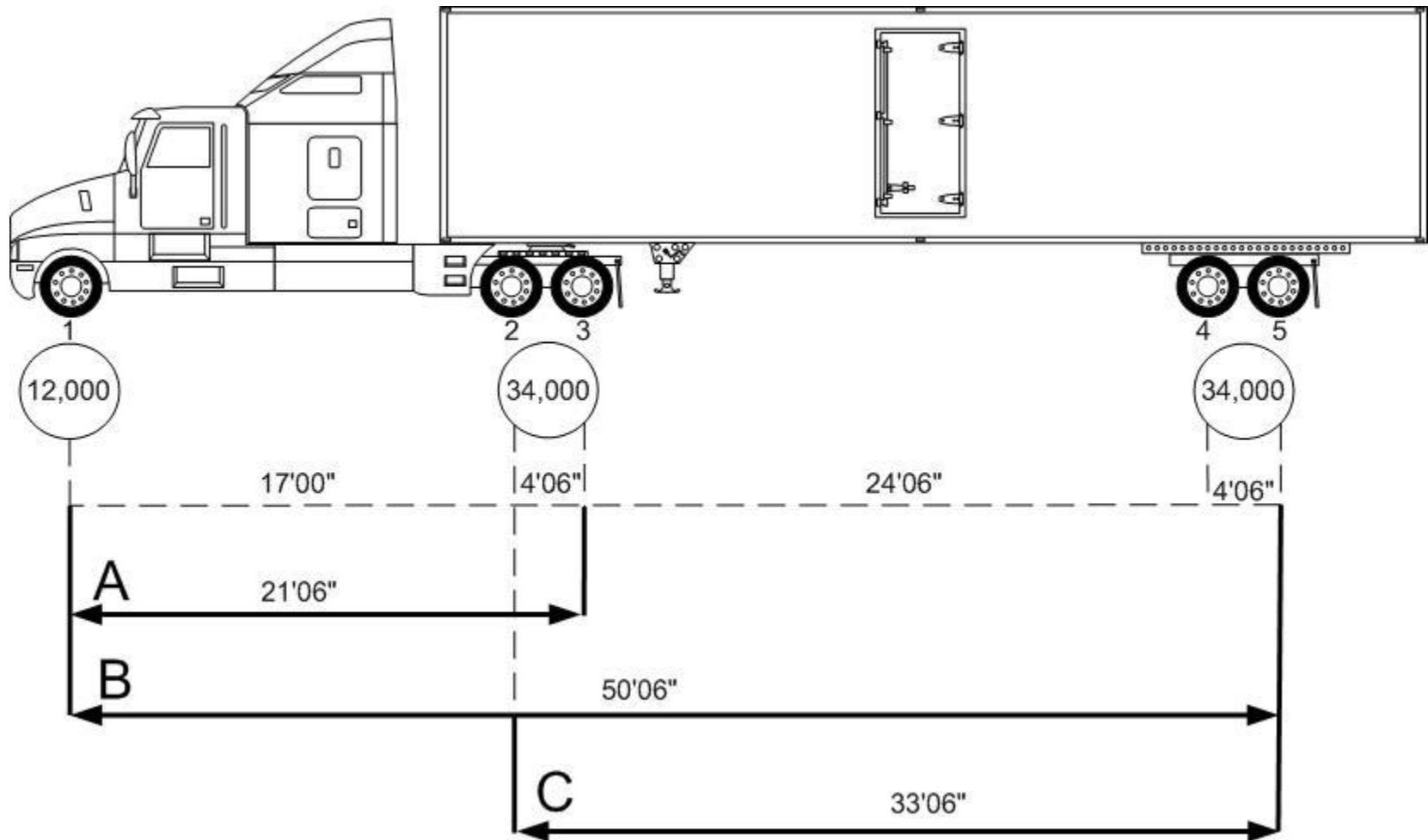



## Extended Weight

- The loaded weight of any group of axles, vehicle, or combination of vehicles shall not exceed any of the following:
  - 600 pounds per inch of tire width.
  - 20,000 pounds per single axle.
  - 34,000 pounds per tandem axle.
  - 105,500 pounds gross weight.
  - The sum of the permissible axle, tandem axle, or group of axle weights shown in [Weight Table 1](#) & [Weight Table 2](#), whichever is less.



## Permit Weight Table 2 Sample 1

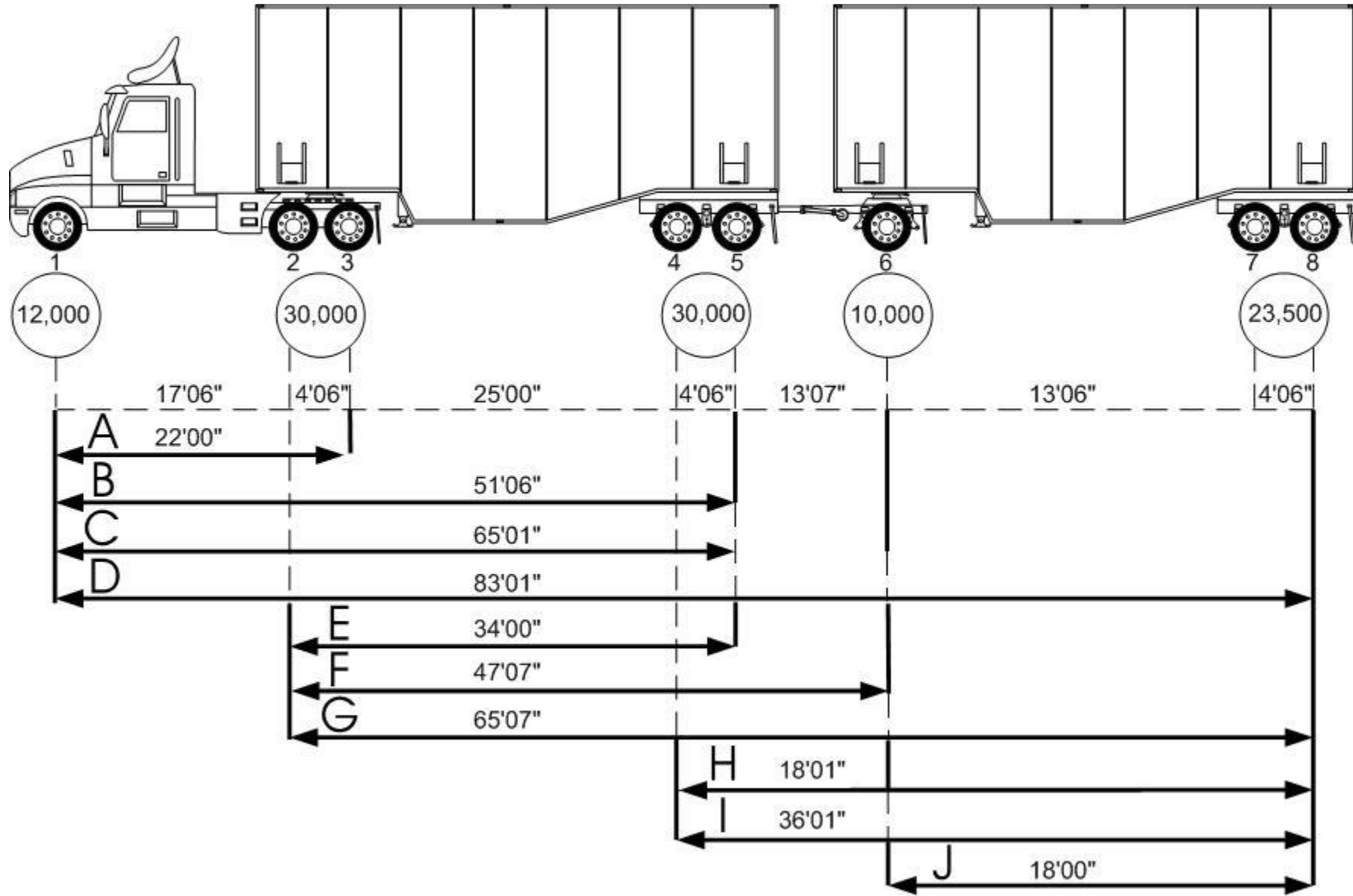





## Permit Weight Table 2 Sample 2

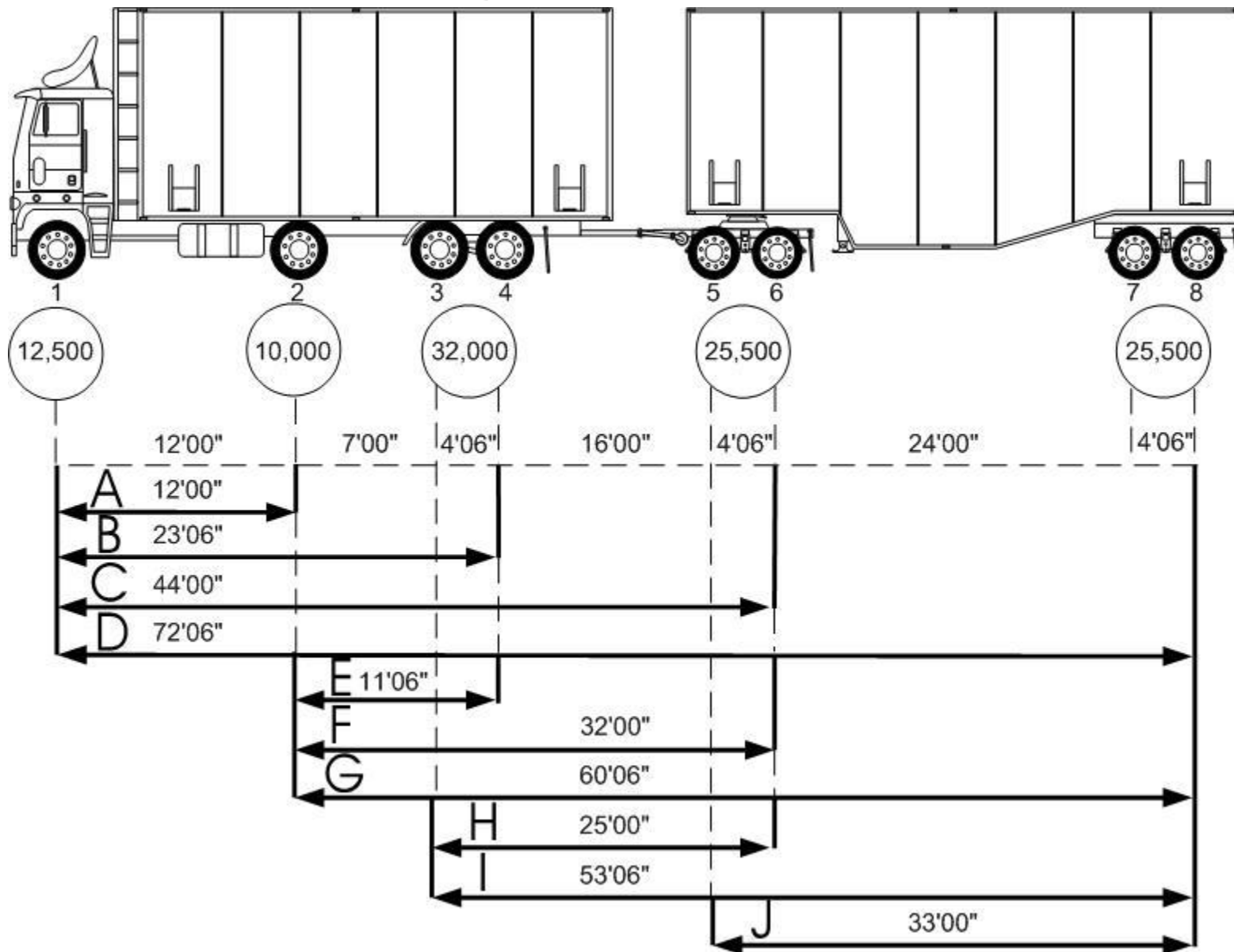



## Weight Table 3

- The loaded weight of any group of axles, vehicle, or combination of vehicles shall not exceed any of the following:
  - 600 pounds per inch of tire width.
  - 21,500 pounds per single axle.
  - 43,000 pounds per tandem axle.
  - The weight shown on the permit.
  - The sum of the permissible axle, tandem axle, or group of axle weights shown in [Weight Table 3](#), whichever is less.
  - Self-Issue Permits are limited to 200,000 lbs gross weight.



# Weight Table 3 Sample

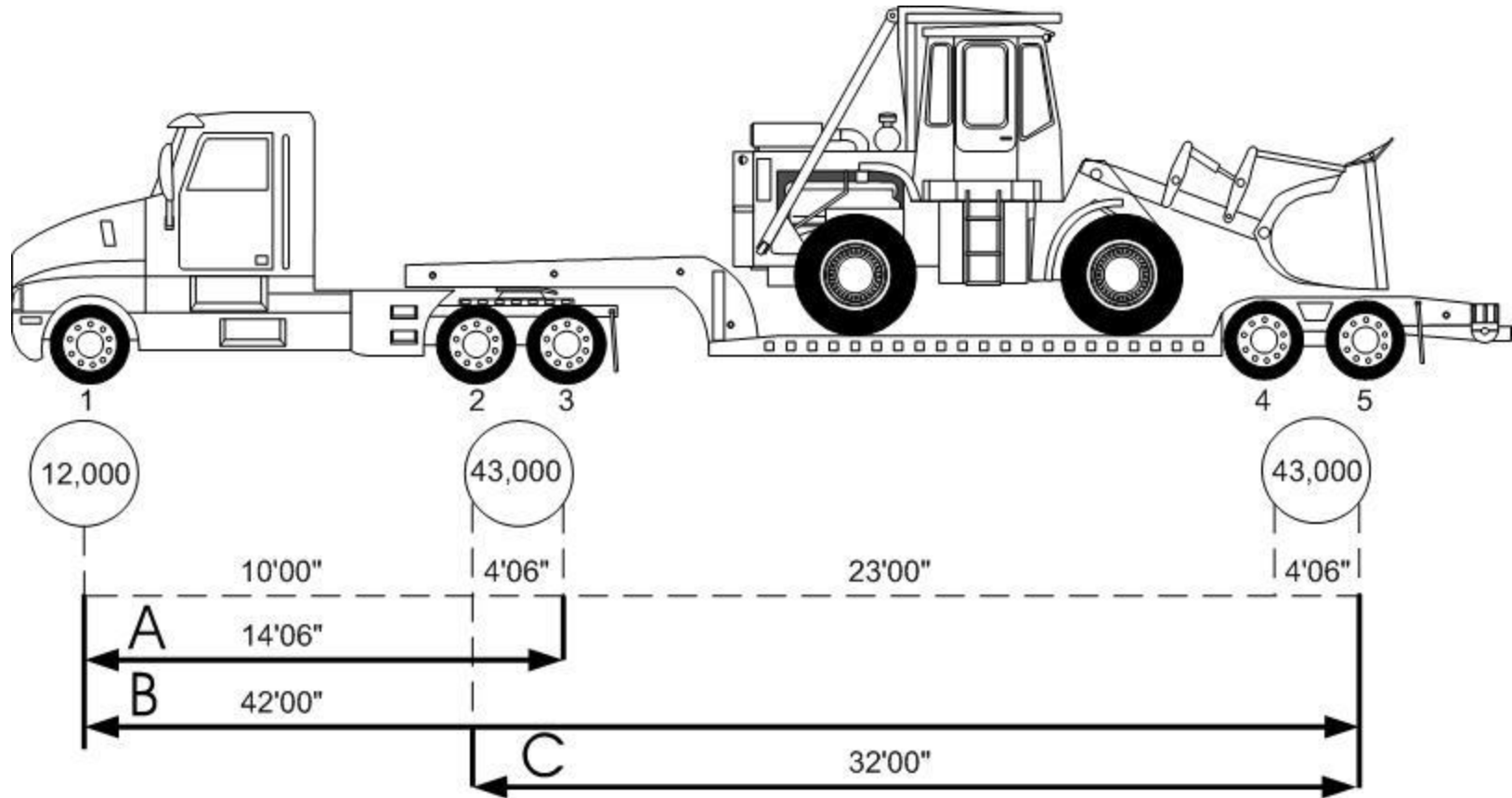



## Weight Table 4

- The loaded weight of any group of axles, vehicle, or combination of vehicles shall not exceed any of the following:
  - 600 pounds per inch of tire width.
  - 21,500 pounds per single axle.
  - 43,000 pounds per tandem axle.
  - The weight shown on the permit.
  - The sum of the permissible axle, tandem axle, or group of axle weights shown in [Weight Table 4](#), whichever is less.
  - Self-Issue Permits are limited to 200,000 lbs gross weight.



## Weight Table 4 Sample 1

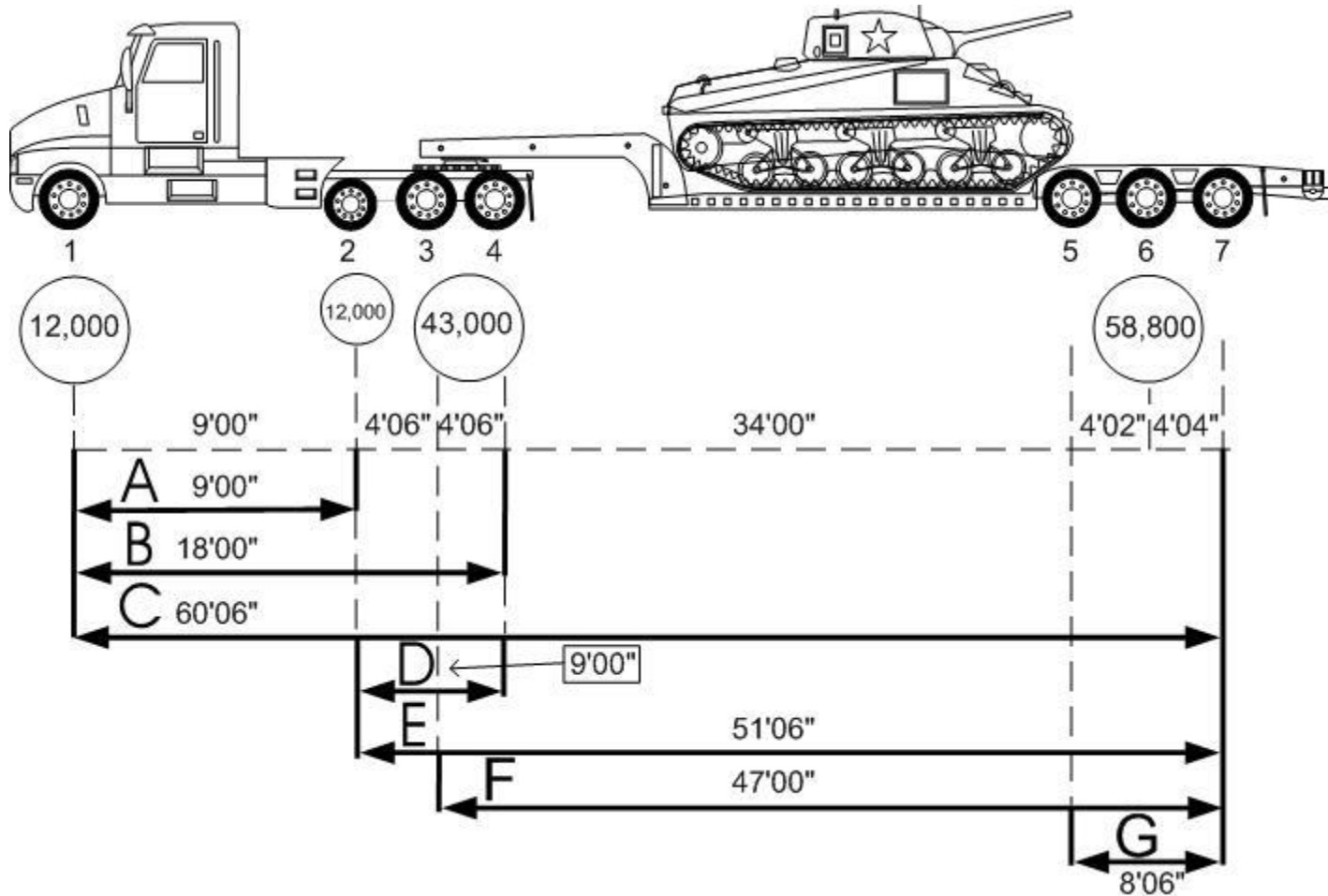





## Weight Table 4 Sample 2

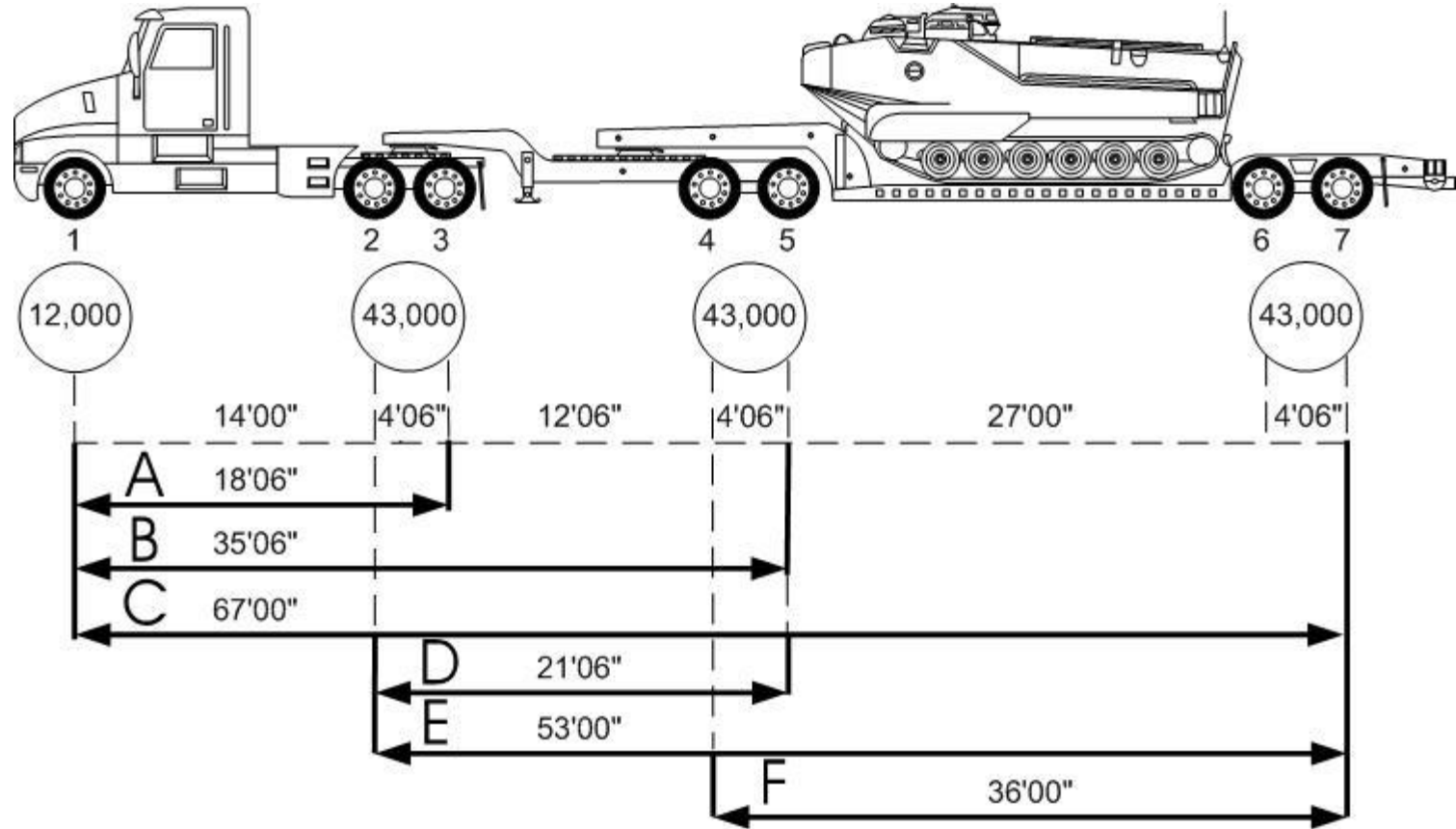



## Weight Table 4 Sample 3

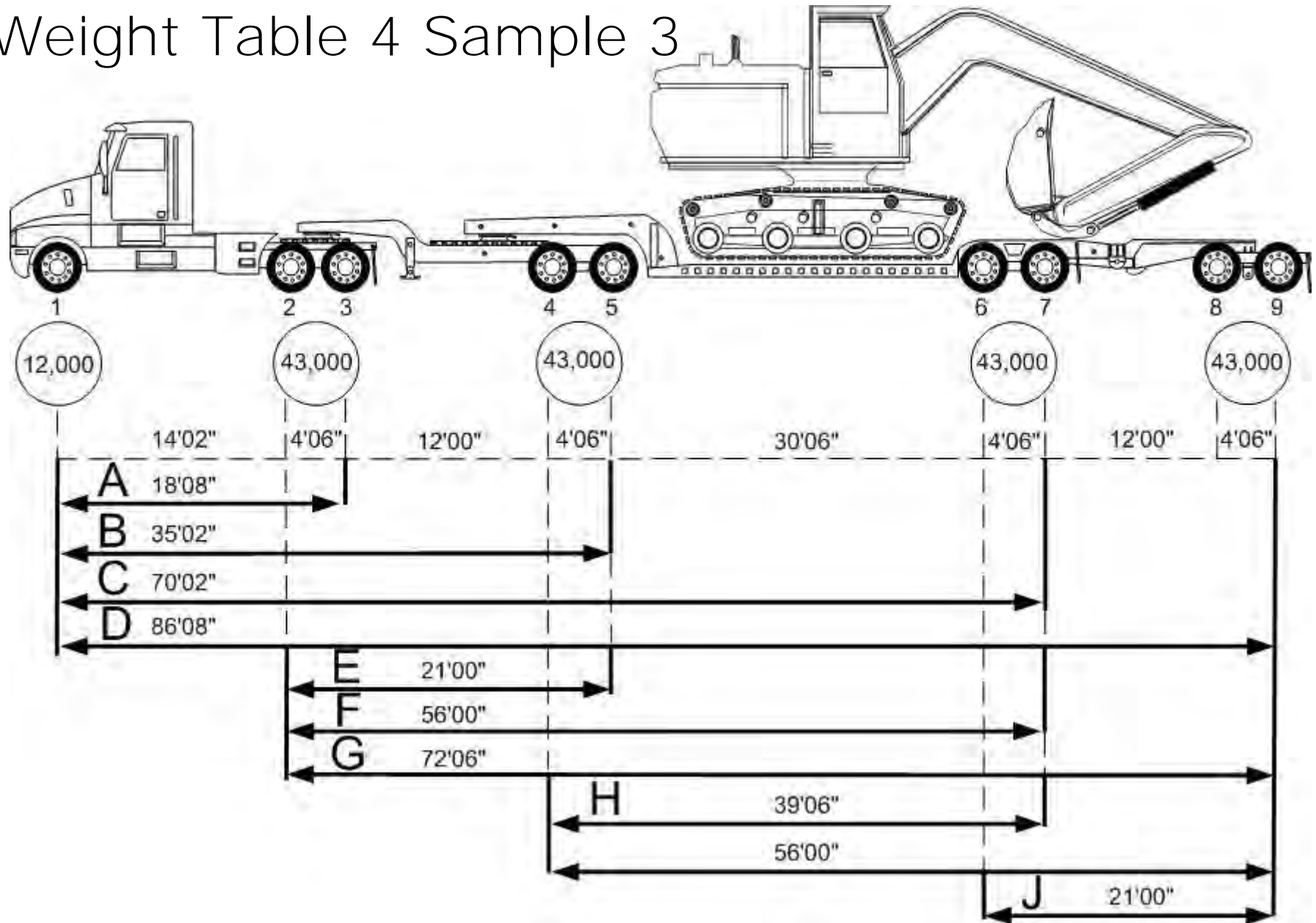



## Weight Table 5

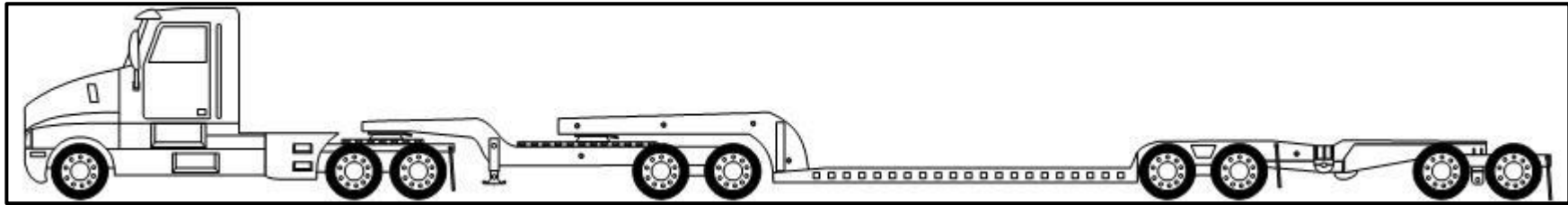

- Minimum of 4 consecutive sets of tandem axles (drivers, jeep, trailer, booster).
- Up to 48,000 pounds per tandem.

All permits requesting [Weight Table 5](#) weights must be processed through the Salem Over-Dimension Permit Unit, and are not allowed on the [Self-Issue Permits Program](#).



## Weight Table 5 by Formula



- Minimum of 4 consecutive sets of tandem axles (drivers, jeep, trailer, booster).
- Up to 60,000 pounds per tandem (if 8-tire, 10' wide axles, commonly called trunnions).

All permits requesting [Weight Table 5](#) by Formula weights must be processed through the Salem Over-Dimension Permit Unit, and are not allowed on the [Self-Issue Permits Program](#).



## Weight Table X (Bridge Reviews)

For axle weights and/or spacings that exceed all published weight tables.

Processed on a case-by-case basis by ODOT Bridge Section.

- May take several days to get an answer.
- Additional traffic control may be required.
- Move may be denied.

All permits requesting Weight Table X must be processed through the Salem Over-Dimension Permit Unit, and are not allowed on the [Self-Issue Permits Program](#).





## What's Permittable by Self-Issue Permit?

- Width.
- Front Overhang.
- Rear Overhang.
- Load Length.
- Overall Length.
- Height.
- Weight.







## Solo Vehicle

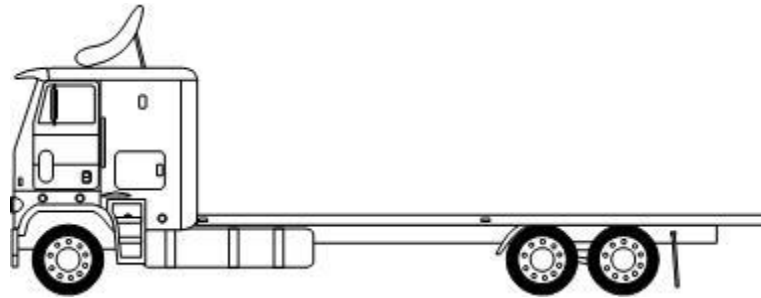

Load Length – Up to 50 feet.

Overall Length – Up to 50 feet including load.

Vehicle length – up to 40 feet.

Height – **Up to 15'00"** subject to vertical clearance routing.

Weight - Permit [Weight Table 1](#), [3](#), [4](#).

Authorized Commodities - One single non-divisible item; multiple items may be hauled at legal weights.

Width – **Up to 14'00"**.



## Solo Vehicle (continued)

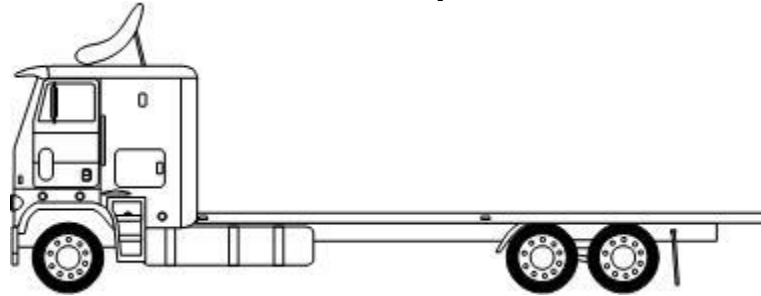

Front Overhang – In excess of 4 feet for non-divisible load, subject to maximum overall length and legal rear overhang.

Rear Overhang – Up to 100% wheelbase for non-divisible load, subject to legal front overhang and overall length.

In other words, no permit is available for excessive front AND rear overhang for the same load.



## Self-Propelled Vehicle



Load Length – Up to 55 feet.

Overall Length – Up to 55 feet.

Height – **Up to 15'00"** subject to vertical clearance routing.

Weight - Permit [Weight Table 1](#), [3](#), [4](#).

Width – **Up to 14'00"**.



## Self-Propelled Vehicle (continued)



Front Overhang – In excess of 4 feet for non-divisible load, subject to maximum overall length and legal rear overhang.

Rear Overhang – Up to 100% wheelbase, subject to legal front overhang and overall length.

In other words, no permit is available for excessive front AND rear overhang for the same load.



## Self-Propelled Vehicle with Boom Dolly

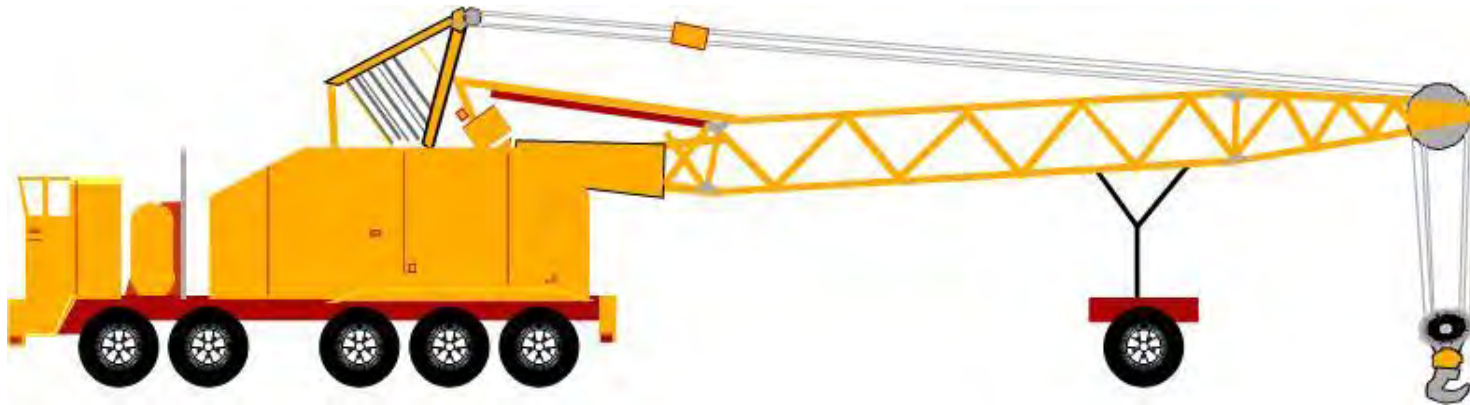

Load Length – Up to 120 feet.

Overall Length – Up to 120 feet.

Height – **Up to 15'00"** subject to vertical clearance routing.

Weight – Permit [Weight Table 1](#), [3](#), [4](#).

Width – **Up to 14'00"**.

Rear Overhang – Up to 1/2 of wheelbase, subject to legal front overhang and overall length.



## Mobile / Modular Unit

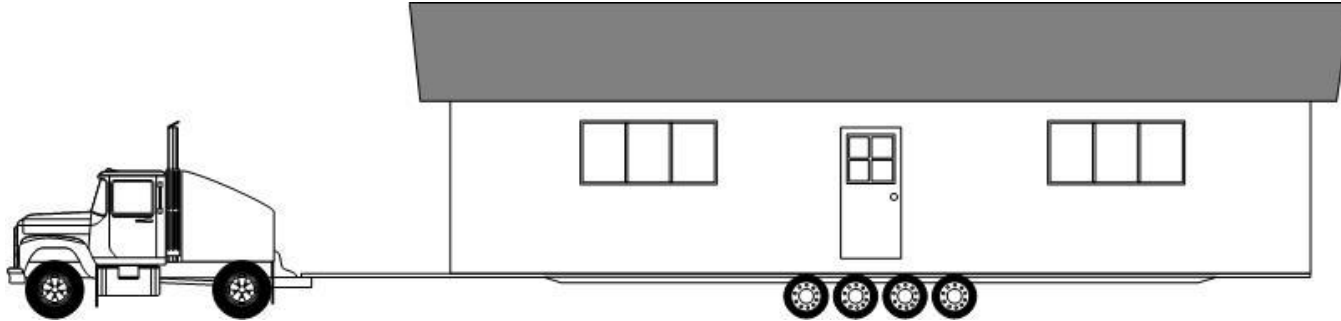

### Definitions

Mobile Unit – **hailed on its' own axles.**

Modular Unit – hailed on a semitrailer or other vehicle.





## Mobile / Modular Unit (continued)

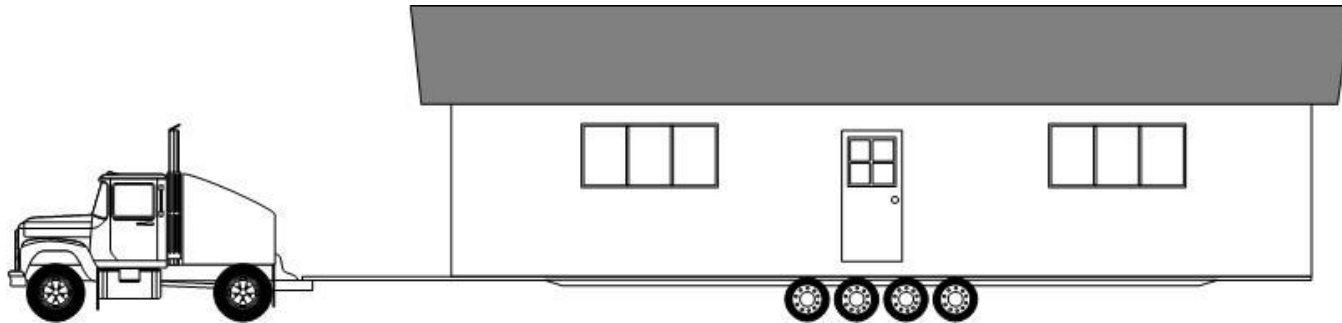

Load Length – Up to 75 feet, including tongue.

Overall Length – Up to 110 feet.

Trailer Length – 75 feet maximum stretch trailer length for hauling modular units. Trailer must be reduced to 53 feet or less in length when unladen.

Height – **Up to 15'00"** subject to vertical clearance routing.

Weight - [Weight Table 1](#).



## Mobile / Modular Unit (continued)

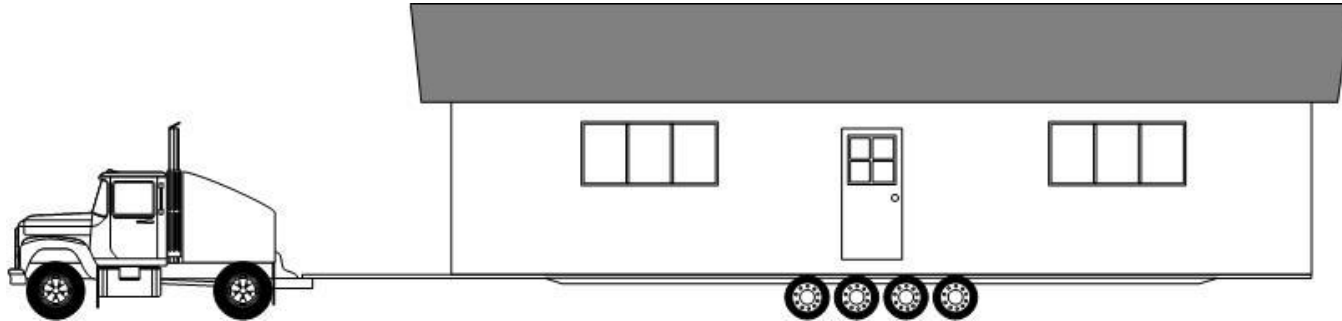

**Width – Up to 14'00", including eave width.**

Rear Overhang - Modular units can be permitted up to 1/2 wheelbase rear overhang subject to maximum overall length.



## Truck Tractor / Semitrailer

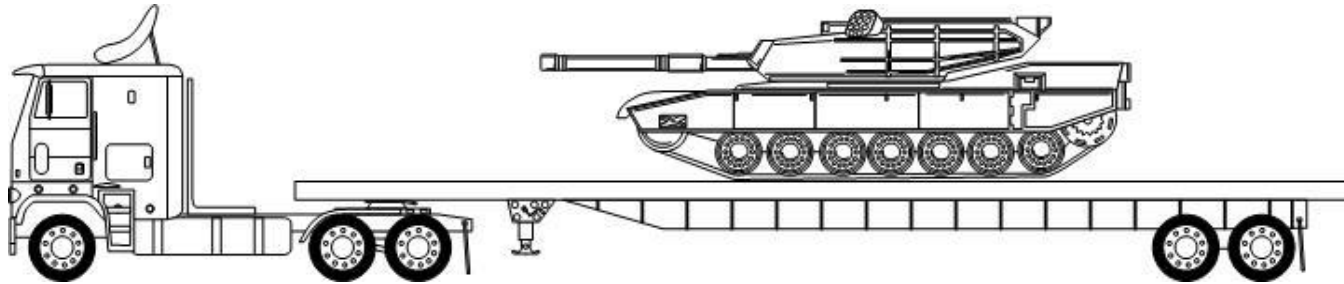

- Width – Up to 14'00".
- Rear Overhang - Up to 1/2 of wheelbase for non-divisible load, subject to legal front overhang and overall length.



## Truck Tractor / Semitrailer (continued)

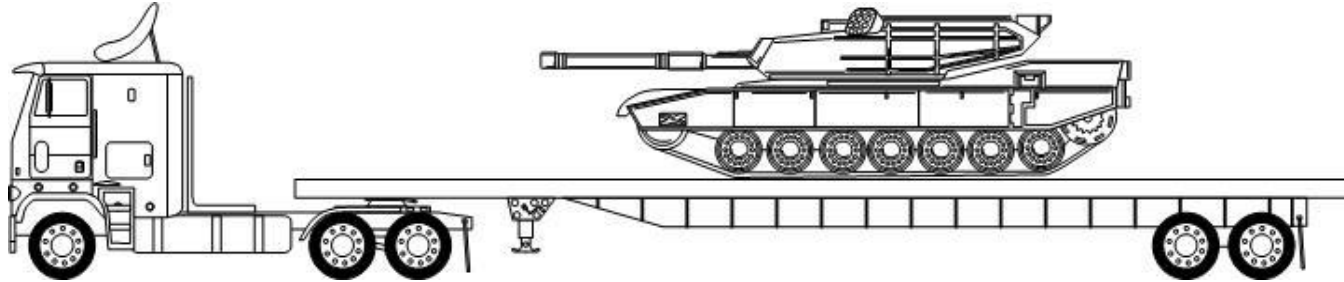

- Trailer Length
  - 53 feet maximum for fixed trailers.  
If flip axle(s) or flip neck extension deployed, or pinned axle(s) added, up to 65 feet.
  - 65 feet maximum for stretch trailers.
  - 65 feet maximum for expanded trailers.



## Truck Tractor / Semitrailer (continued)

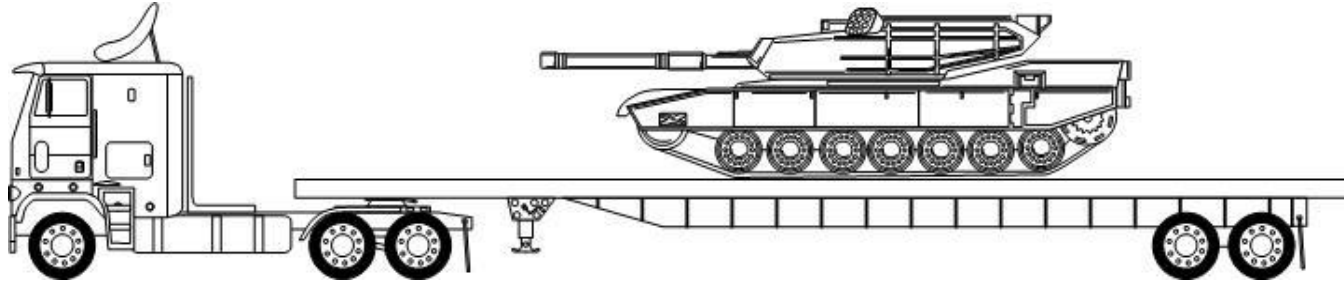

- Overall Length - up to 95 feet in two-lane highways; up to 105 feet on multilane highways.
- Height – **Up to 15'00"**, subject to vertical clearance routing.
- Weight - Permit [Weight Table 1](#), [3](#), [4](#), not to exceed 200,000 lbs gross weight.



## Heavy Haul Combination

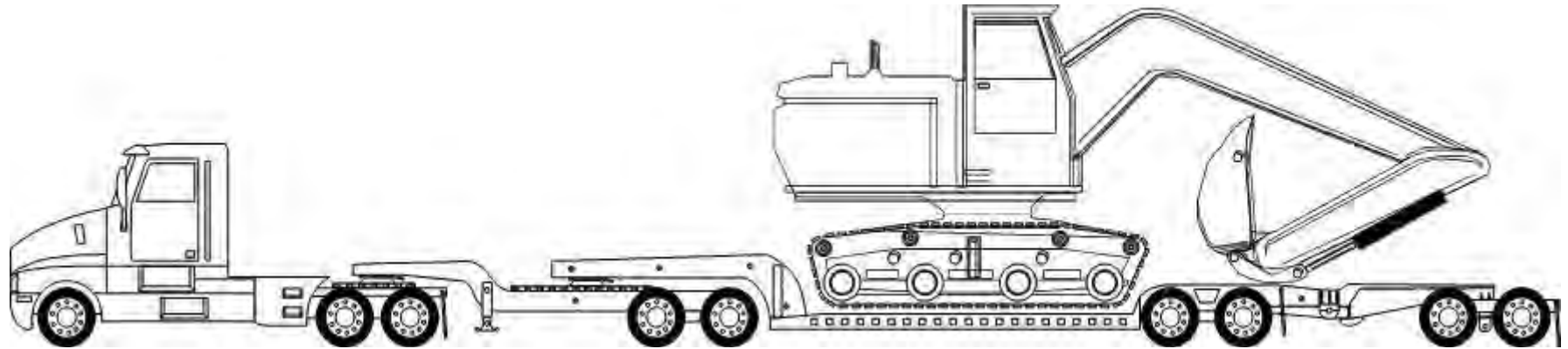

- Width – Up to 14'00".
- Rear Overhang - Up to 1/2 of wheelbase for non-divisible load, subject to legal front overhang and overall length.





## Heavy Haul Combination (continued)

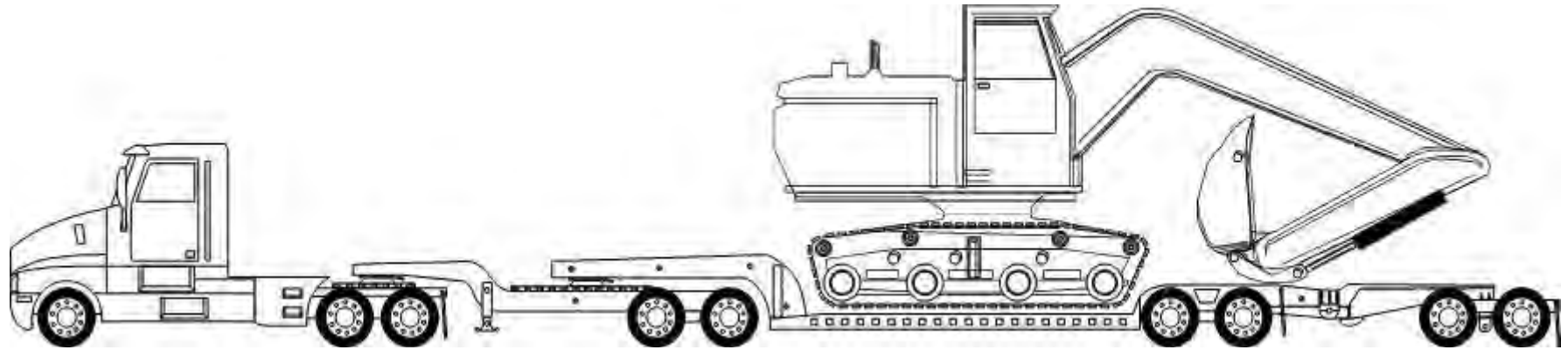

- Trailer Length

- 62 feet maximum fixed trailer.

- If flip axle(s) or flip neck extension deployed, or pinned axle(s) added, up to 65 feet.

- 65 feet maximum when stretched or expanded.



## Heavy Haul Combination (continued)

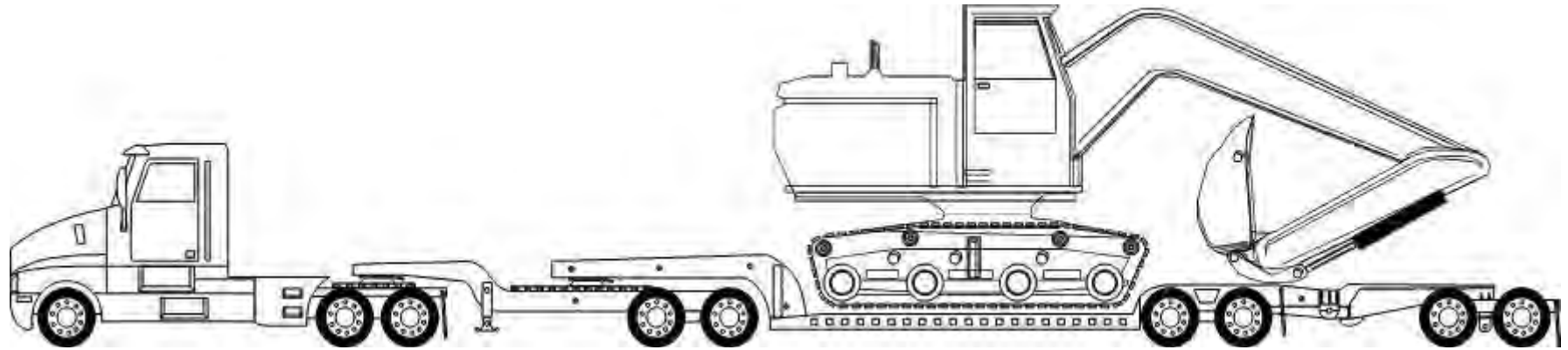

- Overall Length - up to 120 feet.
- Height – **Up to 15'00"**, subject to vertical clearance routing.
- Weight - [Weight Table 1](#), [3](#), [4](#), not to exceed 200,000 lbs gross weight.



## Routing - Length





## Routing - Length

- Are operations on any length-restricted highways? Review [Group Map 1](#) and [Route Map 7](#) for legal lengths allowed.
- Is a longer trailer required to support the load or distribute the weight?
- When hauling a non-divisible load, always travel the shortest distance on any length restricted highway.
- Divisible loads are not authorized to use length restricted highways.



## Routing – Length Example



- US101 is a red route on Route Map 7, from the town of Yachats to MP 185.17, a few miles north of Florence.
- This section of US101 can be used for pickup or delivery of an oversize load, but can NOT be used as a through route.
- Permits must be routed the shortest distance on the red designated section of US101, even if that means detouring to I-5.



## Routing - Width







## Routing - Width

- Is the load a single, non-divisible item?
- Are the appropriate pilot vehicle(s) required, based on the roads travelled?
- Do not use [Route Map 2 purple](#) routes as through routes when over 12 feet wide.
- Do not use Route Map 2 [red](#) routes when operating on a self-issue permit. A single-trip permit issued by CCD staff is required.



## Routing - Height





## Routing - Height

- Is the load a single, non-divisible item?
- Check Appendix A for height restrictions under **15'00"**.
- Check [Route Map 3](#) for height restrictions under **14'6"** on major freight routes.
- Front pilot vehicle with height pole required when **over 14'6"**, unless height declaration on file.



## Vertical Clearance

- All heights provided are with a 4 inch buffer.
- We do not route overheight loads into the buffer.





## Vertical Clearance Lane Usage

- LL = Left Lane
- CL = Center Lane
- RL = Right Lane



Route	Direction	MP	Lane	Max VC	Location	Structure	Description
I-5	NB	297.55	RL only	14'9"	Portland	Brier Ln	Use center lane.





## Vertical Clearance Lane Usage

- LL = Left Lane
- CL = Center Lane
- RL = Right Lane



- Permit Language Example:
  - *I-5, use center lane under Brier Ln at MP297.55.*
- Height may be restricted when using exit or entrance lanes, or crossing under a state-maintained structure.





## Vertical Clearance – Re-Route



Route	Direction	MP	Max VC	Location	Structure
OR99E	NB only	0.53	14'0"	Albany	I-5 Exit 234



## Vertical Clearance – Straddle Centerline

- Two-lane highway only, used only when not enough vertical clearance is available.
- Must stop oncoming and trailing traffic using certified flaggers.
- Check the box that the Certified Flaggers and signing are required.





## Vertical Clearance – Straddle Centerline

- Language Example: Rogue River Bridge.



Route	Direction	MP	Max VC	Location	Structure	Description
OR234	Both	16.01	14'4"	Shady Cove	Rogue River	Straddle center line.





## Vertical Clearance – Straddle Centerline

- Language Example: Rogue River Bridge.



OR234 \*, Stop traffic and straddle centerline across Rogue River Bridge at MP16.01.



## Vertical Clearance – Rolling Stop

- Can be used in place of certified flaggers at 18 locations shown on [Route Map 2](#).
- Language Example: Salt Creek Tunnel
  - OR58 \*, stop traffic and straddle centerline through Salt Creek Tunnel at MP56.01.
- Check the box that the Certified Rolling Stop Method is allowed at this location.



## Routing - Weight

- Is the move near any weight restricted bridges?
  - Some weight restricted bridges have special provisions to cross.
- Bridges restricted to single-trip permit weights are typically NOT posted.





## Routing – Yaquina Bay Bridge near Newport



Stop traffic and straddle centerline when crossing this bridge, when exceeding the weight limits allowed. Certified flaggers and signing required.



## Routing – Reinhart Creek Bridge south of Port Orford



Stop traffic and straddle centerline when crossing this bridge, when exceeding the weight limits allowed. Certified flaggers and signing required.



## Routing Santiam River Bridge near Jefferson

Use I-5 Exit 244 or Exit 238, depending on which side of the bridge is accessed, when exceeding the weight limits allowed.

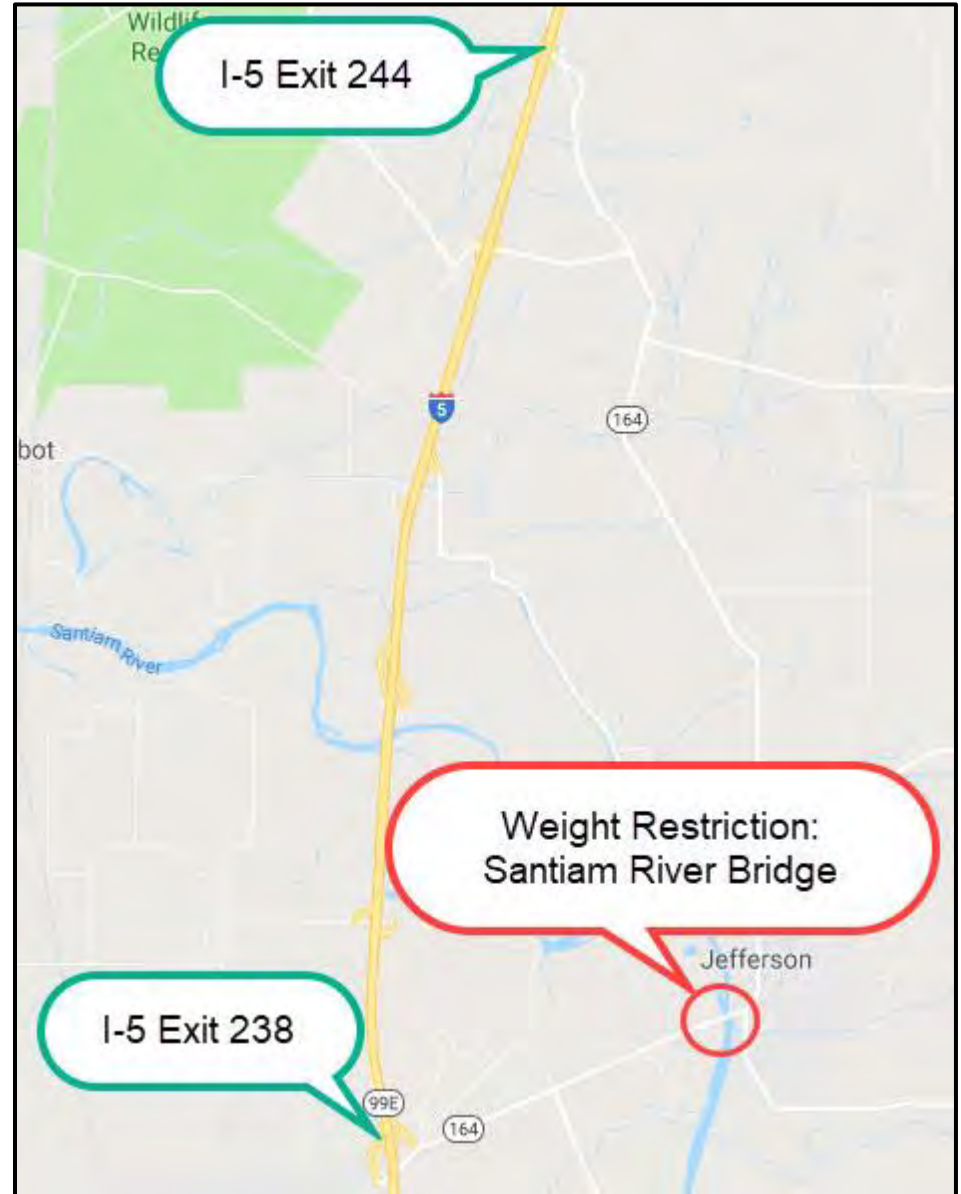



## Restriction List



- Available at [www.oregontruckingonline.com](http://www.oregontruckingonline.com).
- Updated frequently (sometimes several times per day).
- Can be notified via [GovDelivery](#) of updates.







## How to Add Road Restrictions

Restrictions that may impact the move must be included on the permit.

A few considerations when reviewing the restriction list:

- Paving work may encroach into daytime hours, so those restrictions must be included.
- Any restrictions that are active when the permit is effective must be included.
- Check for ramp closures.

**Road Restrictions \*** [Link to Restriction List](#)



## Road Restrictions - Filtering

Filters can be applied to the restriction list to limit the number of road restrictions that are displayed. This may help in determining which restrictions need to be added to the permit.

<u>Restriction Filters</u>				
<u>Day/Night</u>	<u>Width</u>	<u>Overall Length</u>	<u>Ramp/Mainline</u>	<u>Effective Date</u>
<input checked="" type="radio"/> Any Time <input type="radio"/> Day <input type="radio"/> Night	<input type="text" value="0"/> Feet <input type="text" value="0"/> Inches	<input type="text" value="0"/> Feet	<input checked="" type="radio"/> Ramp or Mainline <input type="radio"/> Ramp <input type="radio"/> Mainline	<input checked="" type="radio"/> No Filter <input type="radio"/> Effective Date Before: <input type="text" value="10-02-2018"/>





## Road Restrictions – Filtering – Width

If you wish to filter for width restriction(s), key the maximum width of the load or vehicle being permitted.

For example, if you are routing an 11 foot 00 in. wide load, key 11 feet 00 inches. Width restrictions up to 11 feet 00 in. will not display, while width restrictions of 11 feet 01 in. and higher will display.

<u>Restriction Filters</u>				
<u>Day/Night</u>	<u>Width</u>	<u>Overall Length</u>	<u>Ramp/Mainline</u>	<u>Effective Date</u>
<input checked="" type="radio"/> Any Time <input type="radio"/> Day <input type="radio"/> Night	<input type="text" value="0"/> Feet <input type="text" value="0"/> Inches	<input type="text" value="0"/> Feet	<input checked="" type="radio"/> Ramp or Mainline <input type="radio"/> Ramp <input type="radio"/> Mainline	<input checked="" type="radio"/> No Filter <input type="radio"/> Effective Date Before: <input type="text" value="10-02-2018"/>



# Road Restrictions – Filtering – Ramp/Mainline

Choose “Ramp or Mainline” if you want to filter for both mainline and ramp restrictions. This is the default.

Restriction Filters

<u>Day/Night</u>	<u>Width</u>	<u>Overall Length</u>	<u>Ramp/Mainline</u>	<u>Effective Date</u>
<input checked="" type="radio"/> Any Time <input type="radio"/> Day <input type="radio"/> Night	<input type="text" value="0"/> Feet <input type="text" value="0"/> Inches	<input type="text" value="0"/> Feet	<input checked="" type="radio"/> Ramp or Mainline <input type="radio"/> Ramp <input type="radio"/> Mainline	<input checked="" type="radio"/> No Filter <input type="radio"/> Effective Date Before: <input type="text" value="10-02-2018"/>



## Road Restrictions – Filtering – Ramp/Mainline

Choose “Ramp only” to only display ramp restrictions.

Choose “Mainline only” to only display mainline restrictions. When chosen, ramp closures from one state maintained highway to another state maintained highway will also be displayed.

Example: the ramp from I-5 northbound to I-205 northbound, since the ramp cannot be used without using a mainline highway anyway.

<u>Restriction Filters</u>				
<u>Day/Night</u>	<u>Width</u>	<u>Overall Length</u>	<u>Ramp/Mainline</u>	<u>Effective Date</u>
<input checked="" type="radio"/> Any Time <input type="radio"/> Day <input type="radio"/> Night	<input type="text" value="0"/> Feet <input type="text" value="0"/> Inches	<input type="text" value="0"/> Feet	<input checked="" type="radio"/> Ramp or Mainline <input type="radio"/> Ramp <input type="radio"/> Mainline	<input checked="" type="radio"/> No Filter <input type="radio"/> Effective Date Before: <input type="text" value="10-02-2018"/>



# Road Restrictions – Filtering – Effective Date

Choose “No Filter” if you do not want to filter for the effective date. This is the default.

Choose “Effective Date” if you want to filter for the effective date. This must be used with other filters.

<u>Restriction Filters</u>				
<b>Day/Night</b>	<b>Width</b>	<b>Overall Length</b>	<b>Ramp/Mainline</b>	<b>Effective Date</b>
<input checked="" type="radio"/> Any Time <input type="radio"/> Day <input type="radio"/> Night	<input type="text" value="0"/> Feet <input type="text" value="0"/> Inches	<input type="text" value="0"/> Feet	<input checked="" type="radio"/> Ramp or Mainline <input type="radio"/> Ramp <input type="radio"/> Mainline	<input checked="" type="radio"/> No Filter <input type="radio"/> Effective Date Before: <input type="text" value="10-02-2018"/>



## Road Restrictions – Filtering – Effective Date

If you choose to filter by effective date, the default value for the “Before” date is 14 days from today, normally the last day a single-trip permit could be valid for.

You can choose any day.

For example, if you choose October 2, 2018, a restriction that begins on October 3, 2018 will NOT be displayed.

<u>Restriction Filters</u>				
<b>Day/Night</b>	<b>Width</b>	<b>Overall Length</b>	<b>Ramp/Mainline</b>	<b>Effective Date</b>
<input checked="" type="radio"/> Any Time <input type="radio"/> Day <input type="radio"/> Night	<input type="text" value="0"/> Feet <input type="text" value="0"/> Inches	<input type="text" value="0"/> Feet	<input checked="" type="radio"/> Ramp or Mainline <input type="radio"/> Ramp <input type="radio"/> Mainline	<input checked="" type="radio"/> No Filter <input type="radio"/> Effective Date Before: <input type="text" value="10-02-2018"/>





## Road Restrictions – Filtering – Pro Tip

Use two filters:

- Width of the load or vehicle.
- Effective Date.

<u>Restriction Filters</u>				
<u>Day/Night</u>	<u>Width</u>	<u>Overall Length</u>	<u>Ramp/Mainline</u>	<u>Effective Date</u>
<input checked="" type="radio"/> Any Time <input type="radio"/> Day <input type="radio"/> Night	<input type="text" value="0"/> Feet <input type="text" value="0"/> Inches	<input type="text" value="0"/> Feet	<input checked="" type="radio"/> Ramp or Mainline <input type="radio"/> Ramp <input type="radio"/> Mainline	<input checked="" type="radio"/> No Filter <input type="radio"/> Effective Date Before: <input type="text" value="10-02-2018"/>





## How to Add Pilot Vehicles





## How to Add Pilot Vehicles

- Pilot vehicle(s) may be required, based on the width and overall length. See charts on [Attachment 82A](#) (or [75A](#)) for specific information.
- A front pilot vehicle is required if the height is **greater than 14'6"**, and the carrier has not filed a height declaration.
- **Always indicate the "worst case scenario"**, then specify where the pilot vehicle(s) are required.

**Pilot Vehicle Requirements \***

Enter pilot vehicle information



## How to Add Pilot Vehicles – Example 1

- 11 feet wide load, 75 feet overall length, traveling from Estacada to Eugene.
- Route is OR211, to OR214, to I-5.
- Refer to [Route Map 2](#) and the pilot vehicle chart on [Attachment 82A](#).







## How to Add Pilot Vehicles – Example 1

- OR211 is a **purple** route on [Route Map 2](#), so a front pilot vehicle is required on this route for width.
- OR214 and I-5 are **green** routes on Route Map 2, so no pilot vehicles are required on those routes at this width.



## How to Add Pilot Vehicles – Example 1

- On the permit, check front for two-lane pilot vehicles, and none for four-lane pilot vehicles.

Pilot Vehicles			
<u>2 Lane</u> *	<input type="checkbox"/> None	<input checked="" type="checkbox"/> Front	<input type="checkbox"/> Rear
<u>4 Lane</u> *	<input checked="" type="checkbox"/> None	<input type="checkbox"/> Front	<input type="checkbox"/> Rear

- Indicate that the front pilot vehicle is only required on OR211.

**Pilot Vehicle Requirements \***

1 front pilot vehicle required on OR211 only.

- Alternatively, check “See above for pilot vehicle requirements for entire route.”



## How to Add Pilot Vehicles – Example 2

- 13 feet wide load, 75 feet overall length, traveling from Estacada to Eugene.
- Route is OR211, to OR214, to I-5.
- Refer to [Route Map 2](#) and the pilot vehicle chart on [Attachment 82A](#).





## How to Add Pilot Vehicles – Example 2

- OR211 is a **purple** route on [Route Map 2](#), so front and rear pilot vehicles are required on this route for width.
- OR214 is a **green** route on Route Map 2, so a front pilot vehicle is required on two-lane sections.
- I-5 is a **green** route on Route Map 2 (and by definition, a multilane highway), so no pilot vehicles are required on those routes at this width.





## How to Add Pilot Vehicles – Example 2

- On the permit, check front and rear for two-lane pilot vehicles, and none for four-lane pilot vehicles.

Pilot Vehicles			
<u>2 Lane *</u>	<input type="checkbox"/> None	<input checked="" type="checkbox"/> Front	<input checked="" type="checkbox"/> Rear
<u>4 Lane *</u>	<input checked="" type="checkbox"/> None	<input type="checkbox"/> Front	<input type="checkbox"/> Rear

- Indicate where the pilot vehicles are required.

**Pilot Vehicle Requirements \***

1 front and 1 rear pilot vehicle required on OR211 only.  
1 front pilot vehicle required on other two-lane state highways.

- Alternatively, check “See above for pilot vehicle requirements for entire route.”



## Unladen Authorization

Unladen authorization is required in the following situations:

- A truck tractor/semitrailer combination exceeds the lengths allowed on a length restricted highway.
  - See [Group Map 1](#) and [Route Map 7](#).
- A heavy haul combination exceeds the dimensions allowed on the annual [Unladen Heavy Haul Combination Permit](#).



## Unladen Authorization – More!

If the gross weight is more than 98,000 lbs when unladen, a separate single-trip permit is required.

A front pilot vehicle is required when operating on length restricted highways.

Refer to chart on [Attachment 82A](#) for pilot vehicle(s) required for overwidth and/or overlength unladen hauling equipment.



## Border Locations





## Border Locations

Border location format is setup in the TOL Application.

Acceptable	Unacceptable
OR/ID Border at I-84	Idaho line on I-84
OR/WA Border at US101	Washington line on US101
OR/CA Border at OR39	California line on OR39





# State Highway System – Route Formatting

Interstate Highways must have a dash between the “I” and the route number.

- Example: I-5.



US and OR routes must be designated as such, with no space between “US” or “OR” and the route number.

- Examples: US26; OR217.





# Counties

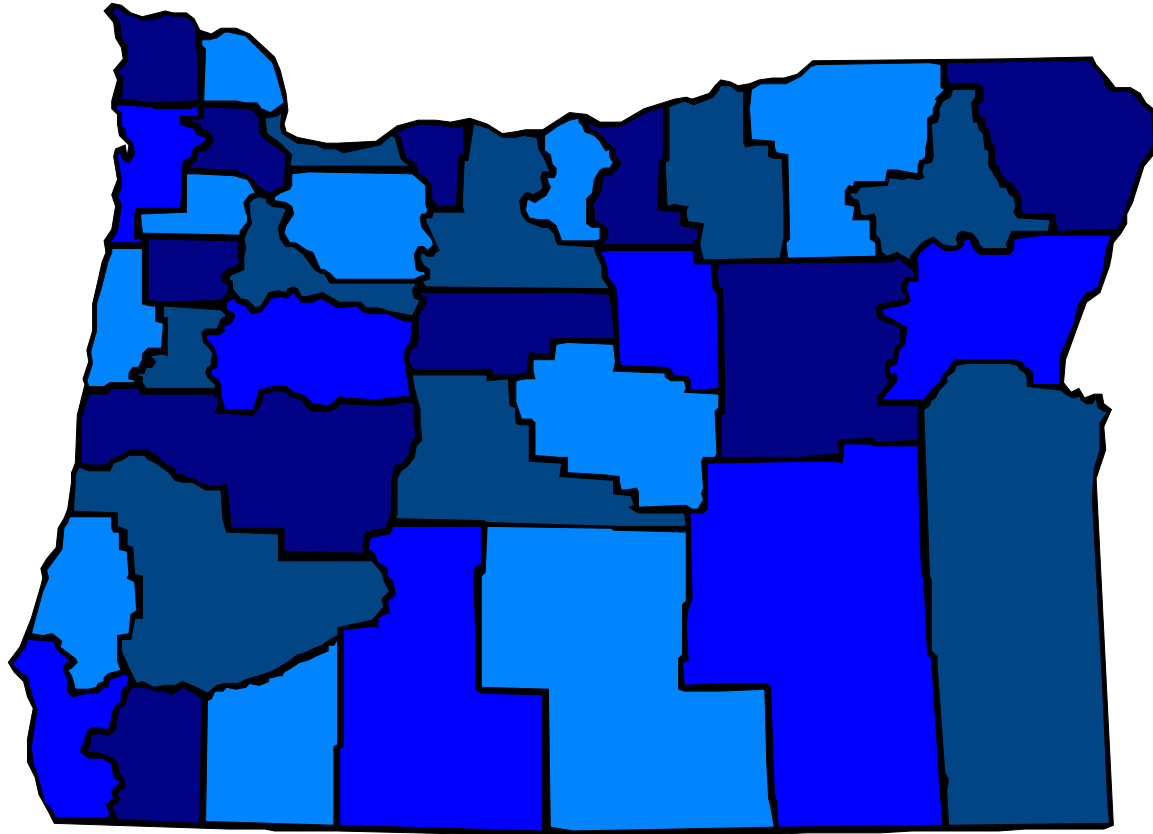



## Counties

- Oregon has 36 counties, each with roads under their jurisdiction, and with their own road departments.
- County contact phone numbers can be found on [COVP Map 4](#) or Appendix C of the [SIPP Manual](#).



## County Approvals

Carrier is required to obtain approval from the appropriate county road authority prior to making the move.

Include the name of the approving person associated with the approval, in the Special Provisions of the permit.

- **"Washington County approval per Aaron Clodfelter"**

Alternatively, obtain a regular single-trip permit.

## County Approvals

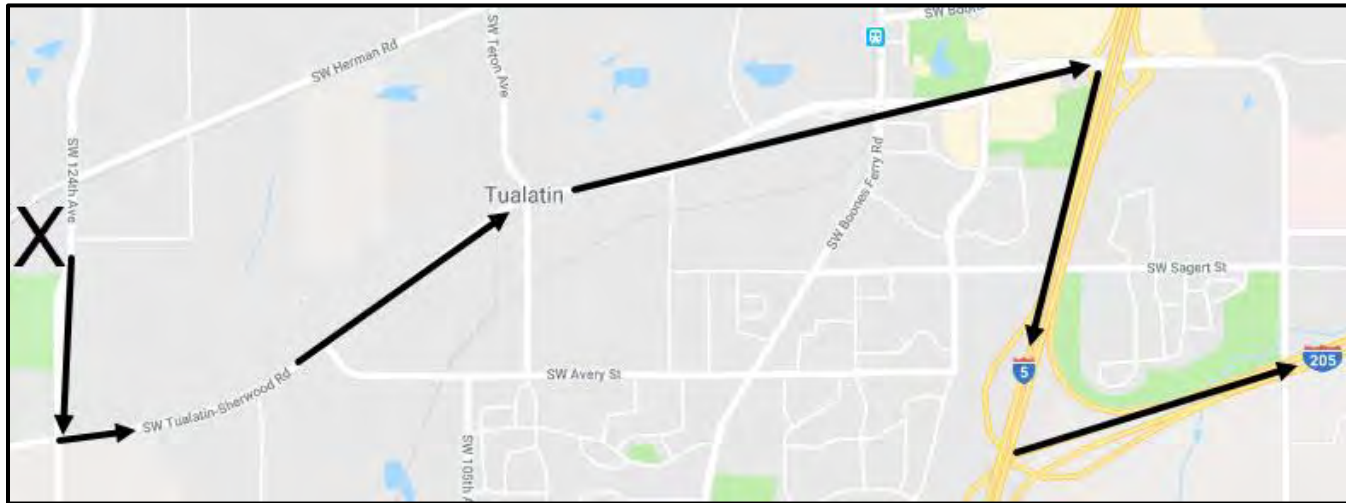

From: Tualatin (19855 SW 124th Ave)

To: OR/WA Border at I-205

Via: 124th Ave; Tualatin-Sherwood Rd; Nyberg St;  
I-5; I-205.

In this example, we expect to see an approval from Washington County, as they have jurisdiction over Tualatin-Sherwood Rd and Nyberg St. 124th Ave is maintained by the City of Tualatin.







## County Approvals - Summary

DO NOT put county roads in the route unless you have specific authorization from the road authority. Authorization must be indicated in Special Provisions.



## City Streets

Oregon has more than 240 incorporated cities. City streets are not authorized on single-trip permits, including self-issue permits.





## City Streets

From: OR/WA Border at I-205

To: Portland (613 NE Columbia Blvd)

Via: I-205, take Exit 23B to US30 Bypass; exit to city streets (Columbia).

From: OR/WA Border at I-205

To: Portland (Junction of US30 Bypass and Columbia Blvd)

Via: I-205, take Exit 23B to US30 Bypass.

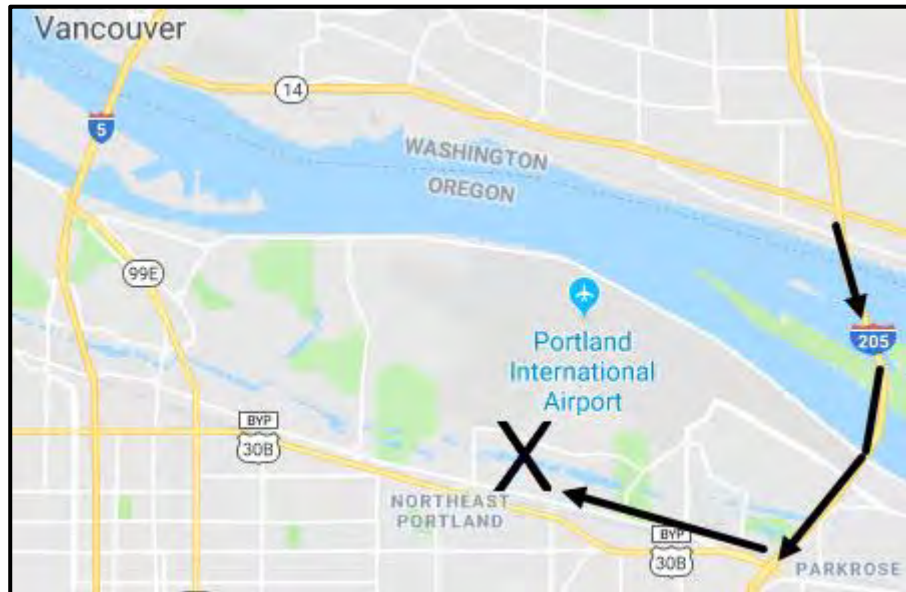

In both examples, the routing is acceptable. The carrier is responsible to obtain an appropriate permit from the City of Portland for use of their roads (Columbia Blvd), as city streets are not authorized on any single-trip permit.



## Starting & Ending Location

Must be specific (an address, cross street, milepoint, or border location).

Acceptable	Unacceptable
Portland (613 NE Columbia Blvd)	Portland
Dayville (Junction of US26 and OR19)	Dayville
Cave Junction (MP32 on US199)	West of Cave Junction





## Routing – More!

Detours (due to road closures or weather) require a separate permit.

Forest Service, Bureau of Land Management, and private roads are NOT authorized on any over-dimension permit.



## Routing – Exit Numbers





## Routing – Exit Numbers

Use of Exit Numbers, where available, are required.  
Exception: exiting one Interstate to another Interstate.

See the [SIPP Manual](#), Appendix B for a list of exit numbers for:

- All Interstates.
- US26 in the Beaverton/Hillsboro area.
- US97.
- OR22 from Salem to Stayton.



## Routing – Direction of Travel

Direction of travel is NOT required, but if added, must be accurate.

Exception: when not using I-405 as a through route, direction of travel on that highway must be indicated.

Why? Two different directions of travel, each with different routing and restrictions.



## Routing – Direction of Travel

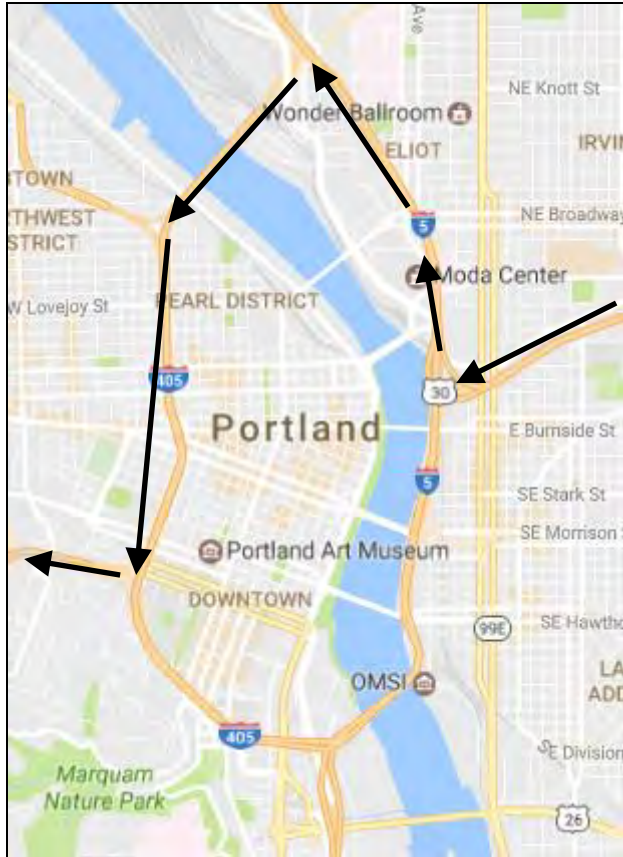

I-84; I-5; I-405  
south, take exit 1D  
to US26.





## Routing – Direction of Travel

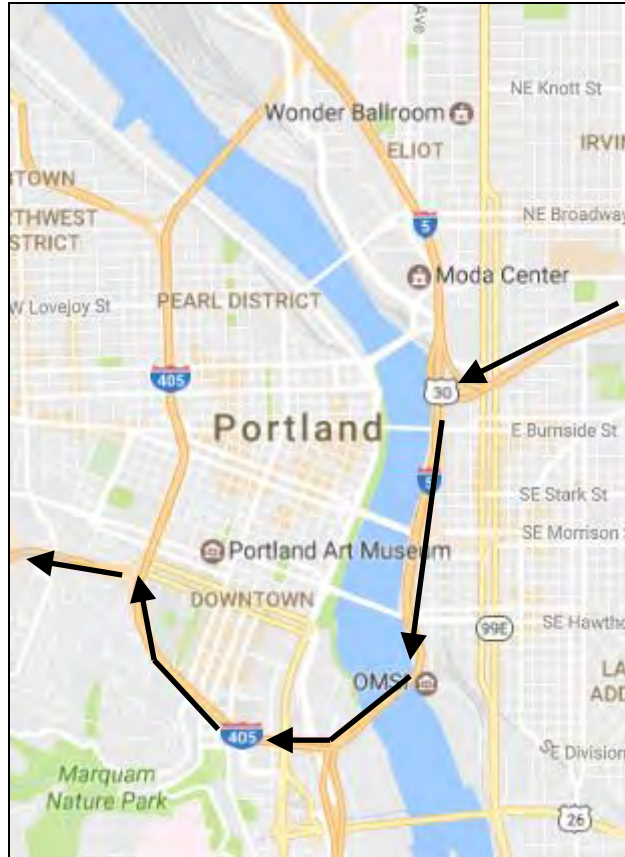

I-84; I-5; I-405  
north, take exit 1D  
to US26.



## TOL Permit Samples

Report RUAF Miles (Road Use Assessment Fees)	<a href="#">More Info</a>		<a href="#">Payment Options</a> Visa, MC, or Direct Payment Only.
Pay Your OD Statement of Account	<a href="#">More Info</a>		Visa, MC, or Direct Payment Only.
Pay For Permits	<a href="#">More Info</a>		Visa, MC, or Direct Payment Only.
OD Permit History	<a href="#">More Info</a>		No Fee
Calculate Oregon Weights	<a href="#">More Info</a>		No Fee
Route Request	<a href="#">More Info</a>		No Fee
Self-Issue Permits	<a href="#">More Info</a>		<a href="#">Payment Options</a>
OD Single-Trip Permit Application	<a href="#">More Info</a>		<a href="#">Payment Options</a>
OD Superload Single-Trip Permit Application	<a href="#">More Info</a>		<a href="#">Payment Options</a>
OD Single-Trip Permit Status Lookup	<a href="#">More Info</a>		No Fee
Cancel Single-Trip Permit Application	<a href="#">More Info</a>		No Fee
Print OD Permits	<a href="#">More Info</a>		No Fee

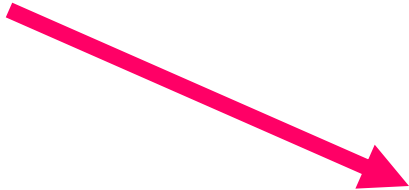



## TOL Permit Samples

### Self-Issue Permits [More Info](#)

Submit

[01 - TT/ST Legal Weight](#) [More Info](#)

[03 - TT/ST Heavy Haul Weights](#) [More Info](#)

[09 - Mobile Unit](#) [More Info](#)

[09 - Modular Unit](#) [More Info](#)

[18 - Tow Truck](#) [More Info](#)

[30 - TT/ST Overlength](#) [More Info](#)

[35 - SP Vehicle with Boom Dolly](#) [More Info](#)

[37 - SP Vehicle WT3](#) [More Info](#)

[38 - SP Vehicle WT4](#) [More Info](#)

[39 - Heavy Haul Combination](#) [More Info](#)

[43 - Solo Vehicle](#) [More Info](#)

**Your SIPP certification expires 05/09/2021**

### Additional Self-Issue Permit Information

[SIPP Manual](#)

[SIPP Training](#)

[Heights Over/Under Interstate Highways - Loads up to 14'6" high](#)

[Heights Over/Under Interstate Highways - Loads up to 15'0" high](#)

[Heights Over/Under US Routes - Loads up to 14'6" high](#)

[Heights Over/Under US Routes - Loads up to 15'0" high](#)

[Heights Over/Under OR Routes - Loads up to 14'6" high](#)

[Heights Over/Under OR Routes - Loads up to 15'0" high](#)



## TOL Permit Samples

11 separate self-issue applications are available, depending on the type of combination and weight.

This allows us to add some edits to the programming.

It is very difficult to program for every scenario, so carriers are still responsible to issue permits in conformance with the program.



## TOL Permit Samples

Truck Tractor/Semitrailer Legal Weight.

Truck Tractor/Semitrailer Heavy Haul Weights.

Mobile Unit.

Modular Unit.

Tow Truck

Truck Tractor/Semitrailer Overlength

Self-Propelled Vehicle with Boom Dolly.

Self-Propelled Vehicle – [Weight Table 3](#).

Self-Propelled Vehicle – [Weight Table 4](#).

Heavy Haul Combination.

Solo Vehicle.





# TOL Permit Samples

**000519 - OREGON TEST ACCOUNT**

**OD TT/ST Legal Weight**

**Select Option**

- Start a New Permit
- Continue a Previous Permit
- Copy a Previous Permit

**Your SIPP certification expires 08/09/2017**



## TOL Permit Samples

**000519 - OREGON TEST ACCOUNT**

**Request/Work A Self-Issue Permit**

---

Type of Permit

TT/ST Legal Weight

\* = Required Fields

---

Carrier Information

<b>Name</b> OREGON TEST ACCOUNT	<b>Account No.</b> 000519	<b>Contact Name *</b> <input type="text"/>
<b>Address</b> 340 NE 11TH AVE PORTLAND, OR 97232	<b>Phone No. *</b> <input type="text"/> <input type="text"/> <input type="text"/>	
<b>Email *</b> <input type="text" value="charles.hutto@odot.state.or.us"/>		
<b>Issue Date</b> 03/17/2017	<b>Effective Date *</b> <input type="text" value="03/17/2017"/>	<b>Expiration Date *</b> <input type="text" value="03/26/2017"/>



## TOL Permit Samples

Non-Divisible Load Dimensions					
<u>Commodity *</u>		<u>Load Length *</u>	<u>Width *</u>	<u>Travel Height *</u>	
<input type="text"/>		<input type="text"/>	<input type="text"/>	<input type="text"/>	<input type="text"/>
<u>Overall Length *</u>	<u>Front Overhang *</u>	<u>Rear Overhang *</u>	<u>Gross Weight *</u>		
<input type="text"/>	<input checked="" type="checkbox"/> Legal <input type="text" value="LEGAL"/>	<input type="text"/>	<input type="text" value="LEGAL"/>		
<u>Description of Vehicles *</u>				<u>Trailer Length *</u>	
<input type="text" value="Truck Tractor/Semitrailer"/>				<input type="text"/>	
<u>Trailer Type *</u>	Fixed	Stretch	Expanded	Special Use	Tow-away
	<input type="radio"/>	<input type="radio"/>	<input type="radio"/>	<input type="radio"/>	<input type="radio"/>
<input type="checkbox"/> Flip Axle(s) deployed	<input type="checkbox"/> Flip neck extension deployed		<input type="checkbox"/> Pinned axle(s)		
<u>Weight Table *</u>	<u>Number of Axles</u>		<a href="#">Online Weight Analysis Calculator</a>		
<input type="text" value="1"/>	<input type="text"/>				



# TOL Permit Samples

Route	
<b><u>Start Location *</u></b> <a href="#">Google Maps</a>	<b><u>End Location *</u></b>
Will you be entering Oregon from out of state? <input type="radio"/> Yes <input checked="" type="radio"/> No	Will you be leaving Oregon with this load? <input type="radio"/> Yes <input checked="" type="radio"/> No
City <input type="text"/>	City <input type="text"/>
Address, Cross Street, or Milepoint <input type="text"/>	Address, Cross Street, or Milepoint <input type="text"/>
<b><u>Route Description *</u></b> <input type="text"/>	



## TOL Permit Samples

### Vehicle Information

Do you know your vehicle plate and/or unit numbers? \*  Yes  No

Enter a Plate or Unit Number below to add that vehicle.\*

Unit:  -- OR -- Plate:

**Vehicle Added to Permit** [More Info](#)

Unit	Plate	VIN	State	Year	Make	
1	2202	YAHU631	1XP6AR8X62D611853	OR	2002	PTRB





## TOL Permit Samples

**Pilot Vehicles**

**2 Lane \***       None       Front       Rear

**4 Lane \***       None       Front       Rear

**Special Provisions**

**Pilot Vehicle Requirements \***

Enter pilot vehicle information, unless checkbox below is checked.

See above for pilot vehicle requirements for entire route.

**Road Restrictions \***    [Link to Restriction List](#)

Enter Road Restriction information, unless checkbox below is checked.

No additional road restrictions required for this route at these dimensions.

**Other Special Provisions**

Enter Other Special Provisions, unless on

No additional special provisions required fo

This permit may be used in conjunction with a valid extended weight permit issued to this vehicle at the dimensions and route listed above. [More Info](#)

\*\* Either certified flaggers and signing required as per the attachment, or the certified rolling stop method is allowed at these locations. The certified rolling stop method requires 3 pilot vehicles. If the carrier chooses to use the certified rolling stop method, this permit is not valid without a copy of the pilot vehicle operator's certification to perform the certified rolling stop method. The certification must be attached to this permit in order for the permit to be valid. [More Info](#)

\*\* Certified flaggers and signing required as per the attachment. [More Info](#)



## TOL Permit Samples

Final Details			
<b>Current Date</b>	03/17/2017	<b>Current Time</b>	2:26 PM
<b>Location</b>	TOL ▼		
<input type="checkbox"/> By clicking Finished, I agree that:			
<ul style="list-style-type: none"><li>• I have successfully attended Self-Issue Permits Program training, as administered by the Motor Carrier Transportation Division of the Oregon Department of Transportation.</li><li>• If required at the permitted dimensions on the permitted route(s), I have applied the correct number and placement of pilot vehicle(s).</li><li>• I have reviewed the restriction list, and added any appropriate restrictions that the driver will need to know.</li><li>• The permitted dimensions and route(s) are allowed under the Self-Issue Permits Program.</li></ul>			
If you have any questions, please contact 503-373-0000, Option 1. We are available Monday-Friday between the hours of 7 AM & 5 PM Pacific time, closed on state holidays, and on Wednesdays from 12 noon to 1 PM Pacific time for staff meetings.			
<input type="button" value="Back"/>		<input type="button" value="Finished"/>	



## TOL Permit Samples

**TT/ST Legal Weight '935985'**

**Your Self-Issue Permit Has Been Completed**

This permit has been issued. Go to the [Reprint Application](#) to view the permit.

If you have any questions, or need help, contact the Over-Dimension Permit Unit at 503-373-0000. We are available Monday-Friday between the hours of 7 AM & 5 PM Pacific time, closed Wednesdays between 12 noon and 1 PM for staff meetings, and on all state holidays.

[OD Menu](#)



## TOL Permit Samples

Permit No.	Unit No.	Commodity	Date Issued	Link
935985	2202	Test s01	03/17/2017	<a href="#">Get Document</a>
935983	2202	OVERWIDTH AND/OR OVERWEIGHT	03/16/2017	<a href="#">Get Document</a>
935982	2202	OVERWIDTH NON-DIVISIBLE LOAD	03/16/2017	<a href="#">Get Document</a>
935965	2201	Test S01 Start 3-9 but saved	03/10/2017	<a href="#">Get Document</a>
935964		TEST PERMIT FOR RUAF	03/08/2017	<a href="#">Get Document</a>
935963		TEST PERMIT FOR RUAF	03/08/2017	<a href="#">Get Document</a>
935958	2202	some large S03 thing	03/07/2017	<a href="#">Get Document</a>
935956	2201	Mobile Unit	03/07/2017	<a href="#">Get Document</a>
935954	2202	Modular Unit	03/07/2017	<a href="#">Get Document</a>
935953	2202	Modular Unit	03/07/2017	<a href="#">Get Document</a>
935952	2202	Modular Unit	03/07/2017	<a href="#">Get Document</a>
935948	2202	Modular Unit	03/07/2017	<a href="#">Get Document</a>



## TOL Permit Samples

OREGON DEPARTMENT OF TRANSPORTATION  
 SELF-ISSUE OVERSIZE PERMIT

000519 OREG017031774210

CARRY THIS PERMIT IN THE CAB OF THE POWER UNIT AT ALL TIMES

Permit No: STP935985	Issue Date	Issue Time	Effective Date	Date of Expiration	Total Fee
Location: TOL	03/17/2017	0224P	03/17/2017	03/26/2017	CHARGED

Permittee: (Name and Address)			Commodity		
OREGON TEST ACCOUNT			Test s01		
340 NE 11TH AVE					
PORTLAND			Carrier File #: 000519		
OR 97232			USDOT: 0143930		

Load Length	Width	Height	Overall Length	Rear Overhang	Front Overhang
50'00"	10'00"	14'00"	75'00"	LEGAL	LEGAL

Legal Weight Table 1	Extended Weight Table	Heavy Haul Weight Table	Gross Weight	Axles
				00

Description of Vehicles: Truck Tractor/Semitrailer

Year	Make	Vin	License	State	Unit No.
2002	PTRB	1XP6AR8X62D611853	YAHU631	OR	2202

From:OR/WA BORDER AT I-205  
 To: salem (3630 fairview industrial dr se)  
 Via: i-205; i-5, take exit 252 to city streets \* (kuebler; fairview industrial).

Pilot Vehicles:	ESAL Rate:
2 Lane None (X) Front ( ) Rear ( )	Oregon Miles:
4 Lane None (X) Front ( ) Rear ( ) Rider ( )	

Special Provisions

This permit is not valid without the following required attachments:  
 82A, H, PWT-1

TRAILER LENGTH: 50  
 TRAILER TYPE: fixed

\*\*\*\*\* SELF-ISSUE PROVISION INFO \*\*\*\*\*  
 no pilot vehicles required.  
 no additional road restrictions required.  
 no other special provisions.

This permit is not valid before issue date and issue time or the effective date, whichever is later. Issue time reflects Pacific Time Zone.

OREGON TAX AND REGISTRATION: Permittee is required to meet all Oregon tax and registration requirements unless exempted by statute or rule.

Page 1 of 2





## Fees

State administrative fees are required on all issued permits, even if the permit is not used.

County fees (if any) are between the carrier and the county.

Carrier required to report road use assessment fee (RUAF) miles (if any) and pay fees, just like any other single-trip permit.



## Decertification

Authorization to self-issue permits may be canceled if:

- Carrier qualifications are no longer in conformance with the program.
- Permits are not issued in conformance with the program.
- Infrastructure damage, as a result of not complying with the provisions of a permitted move.

